

# PARALLEL CONDUIT SUPPORT

## APPLICATIONS:

Parallel conduit supports are used to mount EMT or Rigid Conduits Parallel to a beam, channel or angle supports.

## FEATURES:

Hot Dip Galvanized for added durability and corrosion protection. Provides a secure connection and tight clamping action capable of withstanding heavy loads.

## MATERIAL:

Malleable Iron  
Galvanized Steel Hardware

## FINISH:

Hot Dip Galvanized



E174011

Conforms to finish thickness  
ASTM A123/123M  
UL  
RoHS  
NEMA FB1  
Federal Spec. A-A-50553

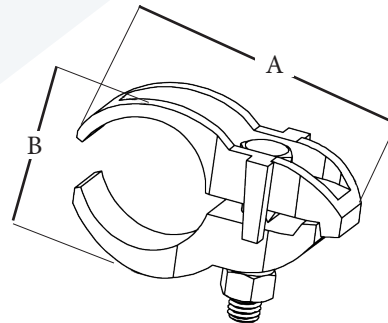

Part No.	UPC	Description	Ship Case	Weight Case	A	B
1561HDG	86737	1/2" Parallel Conduit Support	50	29	2.80	1.42
1562HDG	86738	3/4" Parallel Conduit Support	50	32	2.99	1.47
1563HDG	86739	1" Parallel Conduit Support	50	35	3.19	1.54
1564HDG	86554	1-1/4" Parallel Conduit Support	25	18	3.39	2.01
1565HDG	86555	1-1/2" Parallel Conduit Support	25	24	3.62	2.01
1566HDG	86556	2" Parallel Conduit Support	25	25	4.37	2.87
1567HDG	86557	2-1/2" Parallel Conduit Support	10	14	5.12	3.23
1568HDG	86558	3" Parallel Conduit Support	10	16	5.79	4.06
1569HDG	86559	3-1/2" Parallel Conduit Support	10	19	6.26	4.53
1570HDG	86560	4" Parallel Conduit Support	10	22	6.46	4.61

# PARALLEL CONDUIT SUPPORT

## APPLICATIONS:

Parallel conduit supports are used to mount EMT or Rigid Conduits Parallel to a beam, channel or angle supports.

## FEATURES:

Hot Dip Galvanized for added durability and corrosion protection. Provides a secure connection and tight clamping action capable of withstanding heavy loads.

## MATERIAL:

Malleable Iron  
Galvanized Steel Hardware

## FINISH:

Hot Dip Galvanized



E174011

Conforms to finish thickness  
ASTM A123/123M  
UL  
RoHS  
NEMA FB1  
Federal Spec. A-A-50553

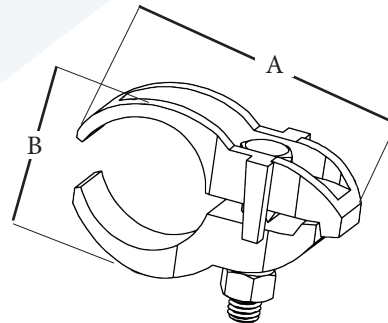

Part No.	UPC	Description	Ship Case	Weight Case	A	B
1561HDG	86737	1/2" Parallel Conduit Support	50	29	2.80	1.42
1562HDG	86738	3/4" Parallel Conduit Support	50	32	2.99	1.47
1563HDG	86739	1" Parallel Conduit Support	50	35	3.19	1.54
1564HDG	86554	1-1/4" Parallel Conduit Support	25	18	3.39	2.01
1565HDG	86555	1-1/2" Parallel Conduit Support	25	24	3.62	2.01
1566HDG	86556	2" Parallel Conduit Support	25	25	4.37	2.87
1567HDG	86557	2-1/2" Parallel Conduit Support	10	14	5.12	3.23
1568HDG	86558	3" Parallel Conduit Support	10	16	5.79	4.06
1569HDG	86559	3-1/2" Parallel Conduit Support	10	19	6.26	4.53
1570HDG	86560	4" Parallel Conduit Support	10	22	6.46	4.61