

HOT DIP GALVANIZED

EDGE TYPE CONDUIT SUPPORT



E174011

Conforms to finish thickness
ASTM A123/123M
UL
RoHS
NEMA FB1
Federal Spec. A-A-50553

APPLICATIONS:

Edge type conduit supports are used to mount EMT or rigid conduits perpendicular to a beam, channel or angle supports.

FEATURES:

Hot Dip Galvanized for added durability and corrosion protection.
Provides a secure connection and tight clamping action capable of withstanding heavy loads.

MATERIAL:

Malleable Iron
Galvanized Steel Hardware

FINISH:

Hot Dip Galvanized

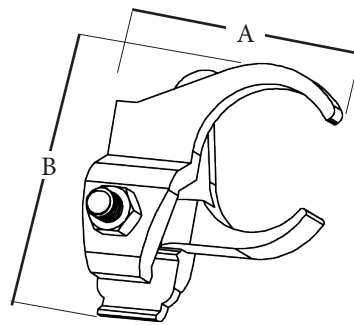
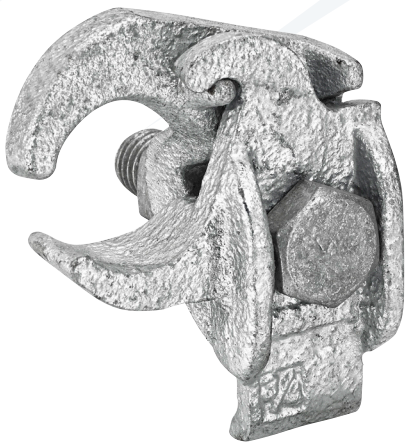

Part No.	UPC	Description	Ship Case	Weight Case	A	B
1571HDG	86561	1/2" Edge Type Conduit Support	50	34	2.10	2.72
1572HDG	86562	3/4" Edge Type Conduit Support	50	36	2.44	3.01
1573HDG	86563	1" Edge Type Conduit Support	50	43	2.57	3.23
1574HDG	86564	1-1/4" Edge Type Conduit Support	25	23	2.96	3.47
1575HDG	86565	1-1/2" Edge Type Conduit Support	25	29	3.27	3.65
1576HDG	86566	2" Edge Type Conduit Support	25	34	3.85	4.36
1577HDG	86567	2-1/2" Edge Type Conduit Support	10	19	4.40	5.05
1578HDG	86568	3" Edge Type Conduit Support	10	23	5.08	5.41

HOT DIP GALVANIZED

EDGE TYPE CONDUIT SUPPORT



E174011

Conforms to finish thickness
ASTM A123/123M
UL
RoHS
NEMA FB1
Federal Spec. A-A-50553

APPLICATIONS:

Edge type conduit supports are used to mount EMT or rigid conduits perpendicular to a beam, channel or angle supports.

FEATURES:

Hot Dip Galvanized for added durability and corrosion protection.
Provides a secure connection and tight clamping action capable of withstanding heavy loads.

MATERIAL:

Malleable Iron
Galvanized Steel Hardware

FINISH:

Hot Dip Galvanized

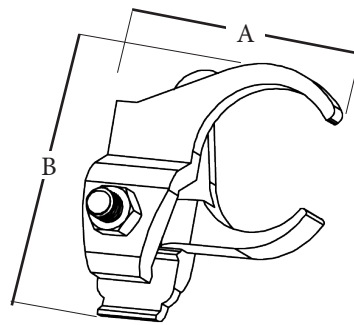
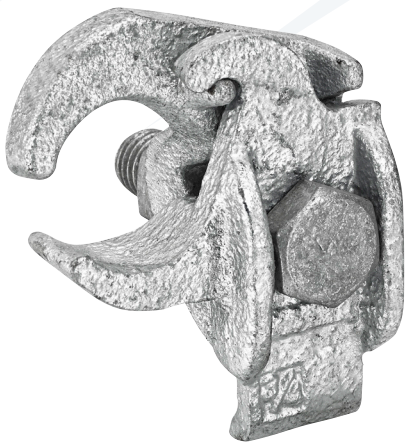

Part No.	UPC	Description	Ship Case	Weight Case	A	B
1571HDG	86561	1/2" Edge Type Conduit Support	50	34	2.10	2.72
1572HDG	86562	3/4" Edge Type Conduit Support	50	36	2.44	3.01
1573HDG	86563	1" Edge Type Conduit Support	50	43	2.57	3.23
1574HDG	86564	1-1/4" Edge Type Conduit Support	25	23	2.96	3.47
1575HDG	86565	1-1/2" Edge Type Conduit Support	25	29	3.27	3.65
1576HDG	86566	2" Edge Type Conduit Support	25	34	3.85	4.36
1577HDG	86567	2-1/2" Edge Type Conduit Support	10	19	4.40	5.05
1578HDG	86568	3" Edge Type Conduit Support	10	23	5.08	5.41