



# SERVICE PARTS LIST

**BULLETIN NO.**  
54-06-2441

SPECIFY CATALOG NO. AND SERIAL NO. WHEN ORDERING PARTS		REVISED BULLETIN 54-06-2440	DATE Aug. 2015
<b>12 Volt Grease Gun</b>			
CATALOG NO.	2446-20	STARTING SERIAL NO.	<b>C39B</b>
		WIRING INSTRUCTION <b>See Reverse Side</b>	

**EXAMPLE:**  
00 0 Component Parts (Small #) Are Included  
When Ordering The Assembly (Large #).

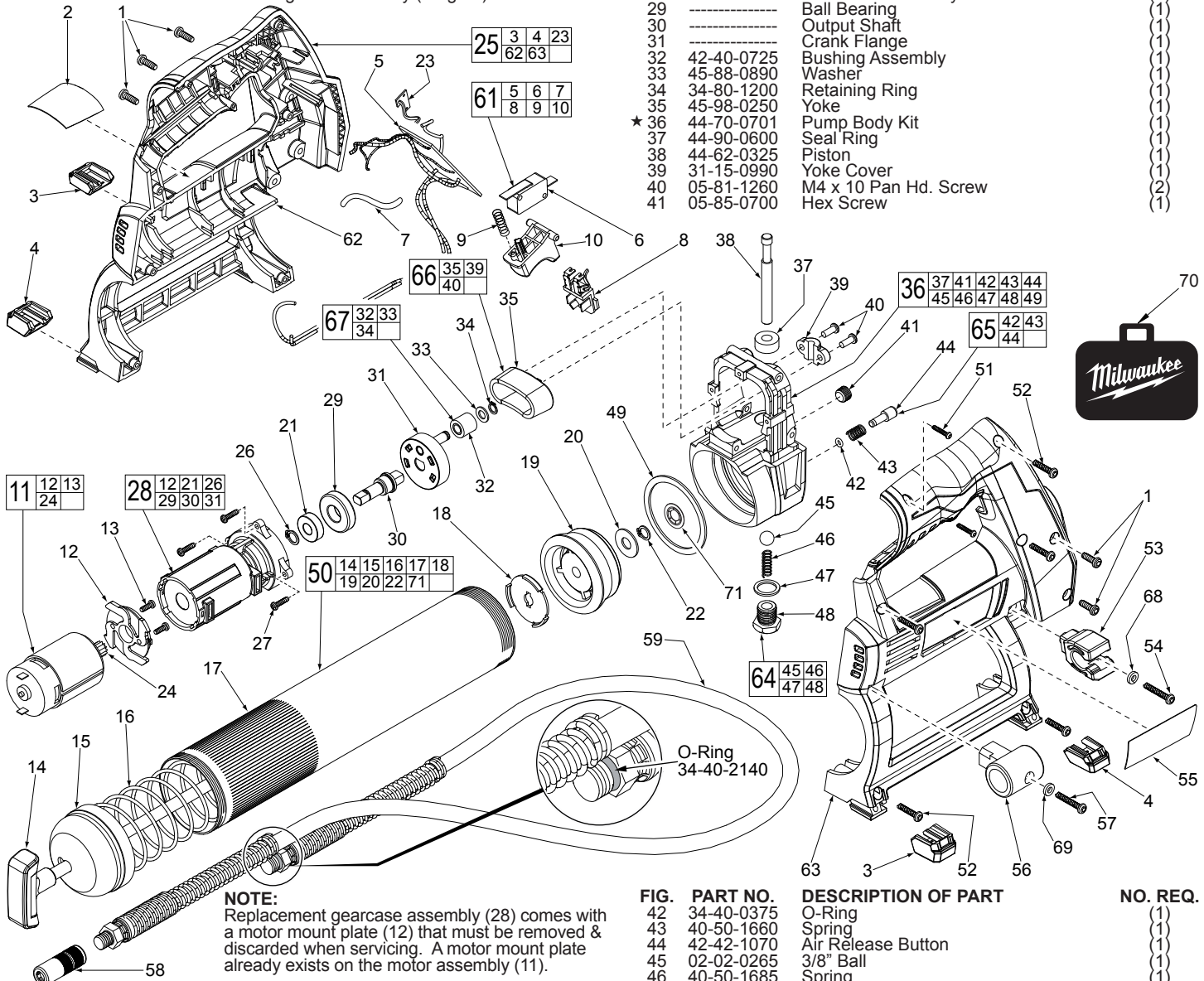

**NOTE:**  
Replacement gearcase assembly (28) comes with a motor mount plate (12) that must be removed & discarded when servicing. A motor mount plate already exists on the motor assembly (11).

FIG.	PART NO.	DESCRIPTION OF PART	NO. REQ.
1	05-74-0985	M4 x 12 Pan Hd. Taptite T-20 Screw	(5)
2	10-15-1390	Warning Label	(1)
3	44-52-1060	Pad - Left Front and Right Rear (Set of 2)	(2)
4	44-52-1070	Pad - Left Rear and Right Front (Set of 2)	(2)
5	-----	PCBA with wiring	(1)
6	23-66-2885	Switch	(1)
7	-----	18 Gauge Red Wire	(1)
8	-----	Battery Connector Block	(1)
9	40-50-4520	Spring	(1)
10	45-72-0300	Trigger	(1)
11	23-30-0600	Motor Assembly	(1)
12	-----	Motor Mount Plate	(1)
13	05-81-0205	M3 x 6 Pan Hd. Screw	(2)
14	44-94-0650	Plunger Rod with Rod	(1)
15	-----	Barrel Tube Cover	(1)
16	-----	Barrel Spring	(1)
17	-----	Barrel	(1)
18	44-66-1525	Stamping Plate	(1)
19	45-06-0890	Rubber Seal	(1)
20	45-88-2030	Washer	(1)
21	-----	Spacer	(1)
22	44-86-1380	Retaining Ring	(1)
23	-----	Fuel Gauge	(1)
24	-----	Motor Pinion	(1)
25	31-50-2700	Housing Assembly Kit	(1)
26	44-86-1380	Retaining Ring	(1)
★27	05-81-1221	M4 x 12 Pan Hd. Screw	(3)

FIG.	PART NO.	DESCRIPTION OF PART	NO. REQ.
★28	14-29-0601	Gearcase Assembly	(1)
29	-----	Ball Bearing	(1)
30	-----	Output Shaft	(1)
31	-----	Crank Flange	(1)
32	42-40-0725	Bushing Assembly	(1)
33	45-88-0890	Washer	(1)
34	34-80-1200	Retaining Ring	(1)
35	45-98-0250	Yoke	(1)
★36	44-70-0701	Pump Body Kit	(1)
37	44-90-0600	Seal Ring	(1)
38	44-62-0325	Piston	(1)
39	31-15-0990	Yoke Cover	(1)
40	05-81-1260	M4 x 10 Pan Hd. Screw	(2)
41	05-85-0700	Hex Screw	(1)
42	34-40-0375	O-Ring	(1)
43	40-50-1660	Spring	(1)
44	42-42-1070	Air Release Button	(1)
45	02-02-0265	3/8" Ball	(1)
46	40-50-1685	Spring	(1)
47	45-88-0905	Copper Washer	(1)
48	45-04-1010	Plug Screw	(1)
49	43-44-1100	Rubber Gasket	(1)
50	30-06-0200	Barrel Assembly	(1)
51	06-82-2385	M2.6 x 14 Pan Hd. T-8 Screw	(2)
52	06-82-7470	6 x 11/16" Pan Hd. Plastite T-15 Screw	(5)
53	43-75-0500	Grease Hose Holster	(1)
54	05-81-1275	M4 x 20 Pan Hd. Taptite T-20 Screw	(1)
55	12-20-2446	Service Nameplate Kit	(1)
56	42-90-0575	Coupler Holster	(1)
57	06-82-7475	6 x 7/8" Pan Hd. Plastite T-15 Screw	(1)
58	42-90-0700	Coupler Assembly	(1)
59	14-37-0300	Grease Hose Assembly	(1)
61	23-66-2890	Switch Assembly	(1)
62	-----	Left Housing Halve	(1)
63	-----	Right Housing Halve	(1)
64	45-04-1030	Plug Screw Kit	(1)
65	42-42-1080	Air Release Kit	(1)
66	45-98-0300	Yoke Kit	(1)
67	42-40-1150	Bushing Kit	(1)
68	-----	Spring Washer	(1)
69	-----	Washer	(1)
70	42-55-2446	Soft Carrying Case	(1)
71	44-86-1400	Self-Locking Retaining Ring	(1)

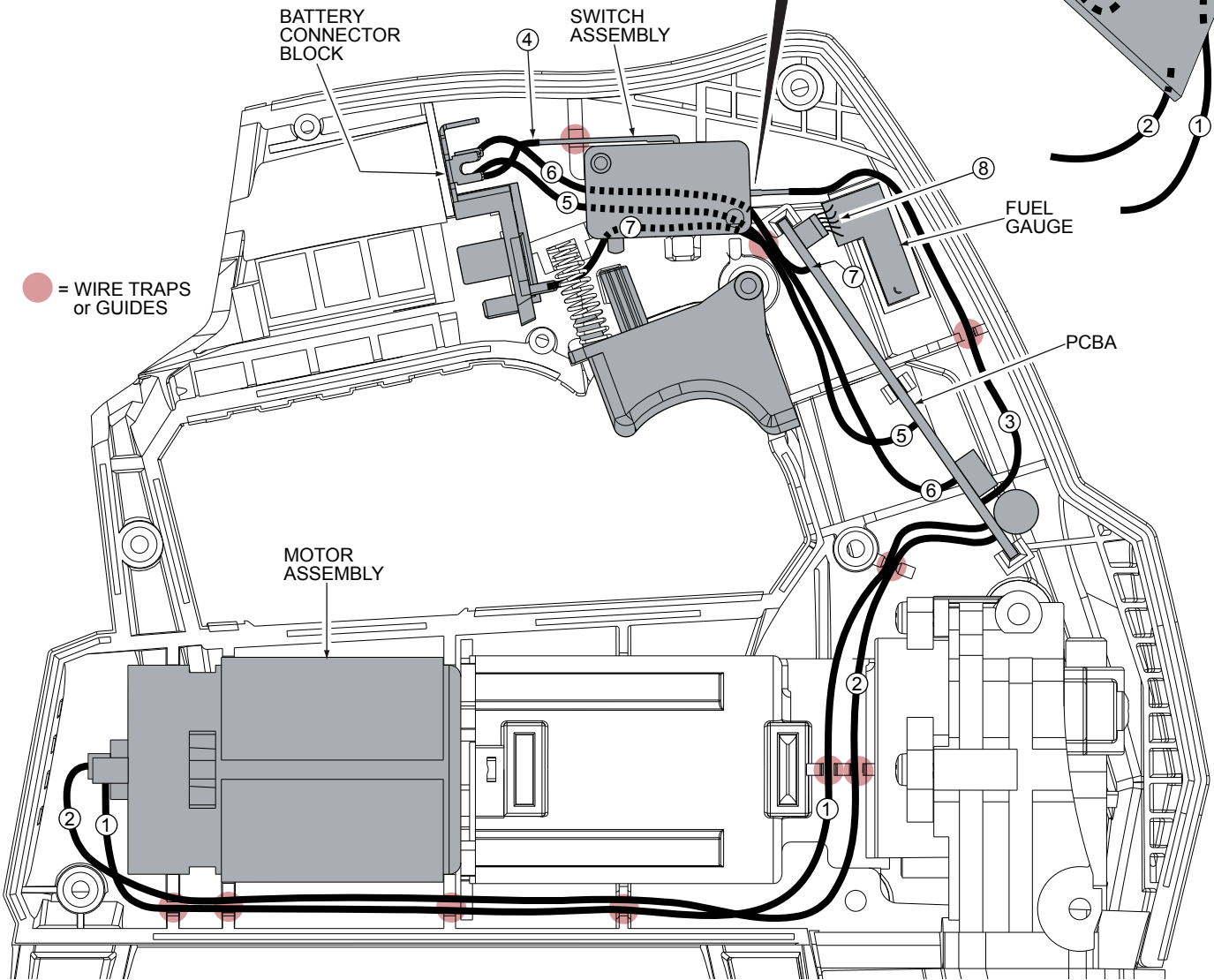
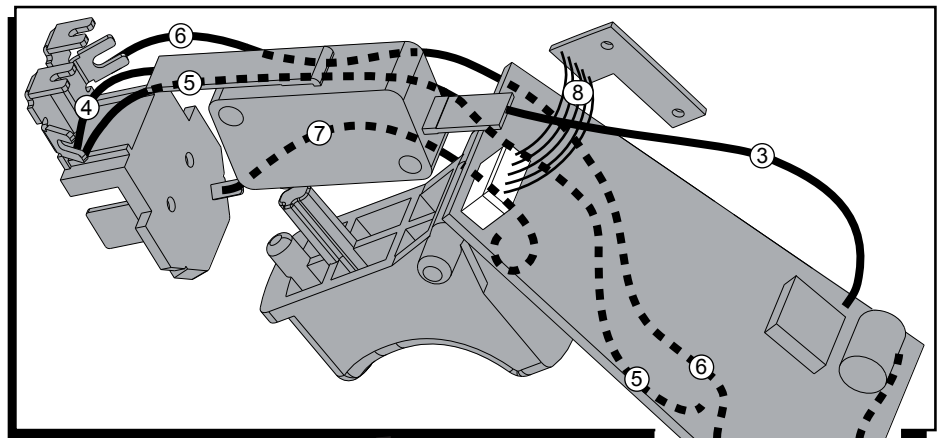

● = WIRE TRAPS  
or GUIDES

### WIRING SPECIFICATIONS

Wire No.	Wire Color	Origin or Gauge	Length	Terminals, Connectors and 1 or 2 End Wire Preparation
1	Red	----	----	Wire connects from PCBA to (+) right side of motor.
2	White	----	----	Wire connects from PCBA to (-) left side of motor.
3	Blue	----	----	Wire connects from PCBA to front of switch.
4	Red	----	----	Wire connects from connector block (with #5) to back of switch.
5	Red	----	----	Wire connects from PCBA to connector block (with #4).
6	Black	----	----	Wire connects from PCBA to connector block.
7	White	----	----	Wire connects from PCBA to connector block.
8	----	----	----	Fuel gauge harness plugs into PCBA.

AS AN AID TO REASSEMBLY,  
TAKE NOTICE OF WIRE ROUTING AND  
POSITION IN WIRE GUIDES AND TRAPS  
WHILE DISMANTLING TOOL.

BE CAREFUL AND AVOID PINCHING  
WIRES BETWEEN HANDLE HALVES  
WHEN ASSEMBLING.



# SERVICE PARTS LIST

**BULLETIN NO.**  
54-06-2441

SPECIFY CATALOG NO. AND SERIAL NO. WHEN ORDERING PARTS		REVISED BULLETIN	DATE
<b>12 Volt Grease Gun</b>		54-06-2440	Aug. 2015
<b>CATALOG NO.</b>	<b>2446-20</b>	<b>WIRING INSTRUCTION</b>	
<b>STARTING SERIAL NO.</b>	<b>C39B</b>	<b>See Reverse Side</b>	

**EXAMPLE:**  

00	0
----	---

 Component Parts (Small #) Are Included When Ordering The Assembly (Large #).

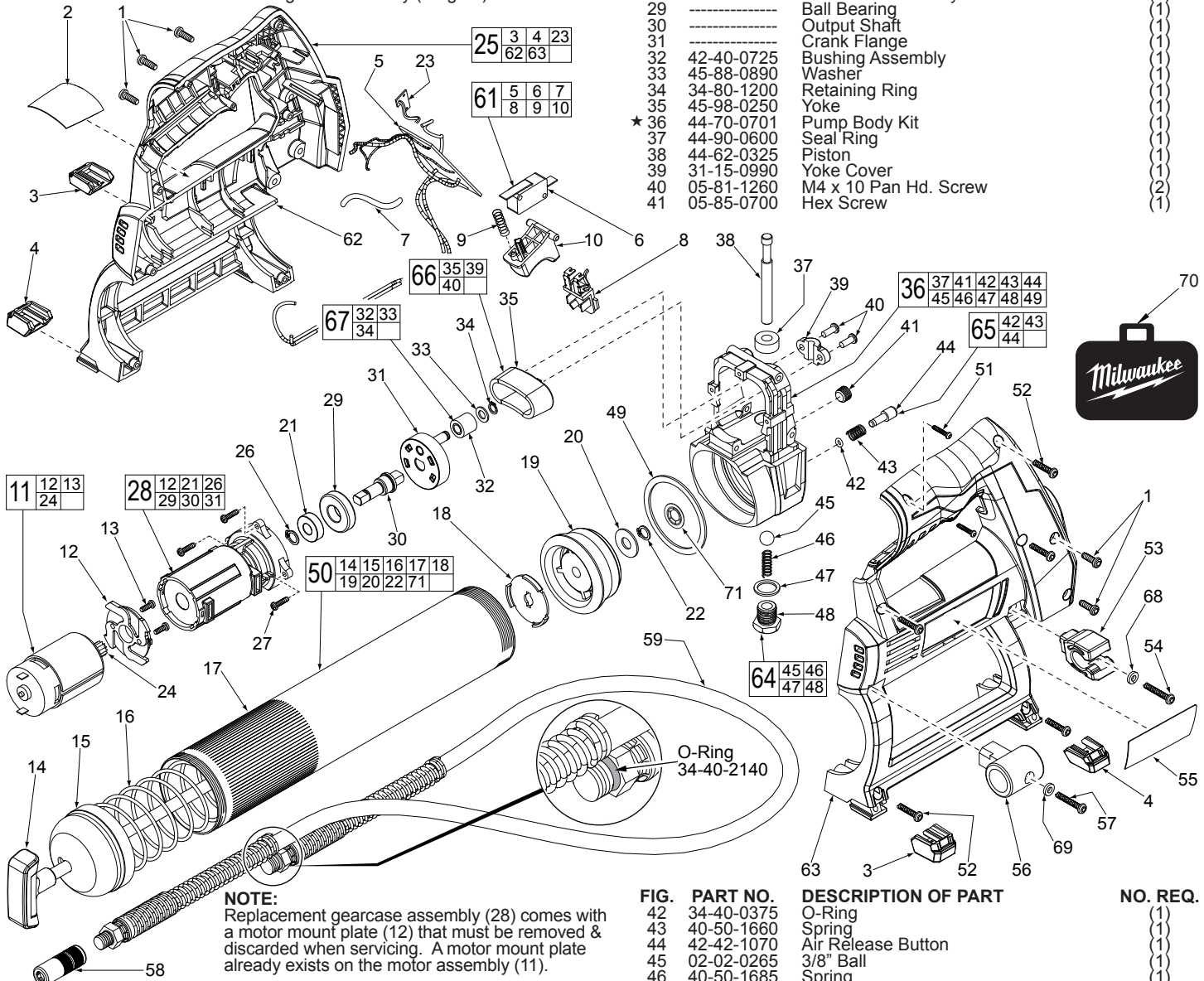

**NOTE:**  
 Replacement gearcase assembly (28) comes with a motor mount plate (12) that must be removed & discarded when servicing. A motor mount plate already exists on the motor assembly (11).

FIG.	PART NO.	DESCRIPTION OF PART	NO. REQ.
1	05-74-0985	M4 x 12 Pan Hd. Taptite T-20 Screw	(5)
2	10-15-1390	Warning Label	(1)
3	44-52-1060	Pad - Left Front and Right Rear (Set of 2)	(2)
4	44-52-1070	Pad - Left Rear and Right Front (Set of 2)	(2)
5	-----	PCBA with wiring	(1)
6	23-66-2885	Switch	(1)
7	-----	18 Gauge Red Wire	(1)
8	-----	Battery Connector Block	(1)
9	40-50-4520	Spring	(1)
10	45-72-0300	Trigger	(1)
11	23-30-0600	Motor Assembly	(1)
12	-----	Motor Mount Plate	(1)
13	05-81-0205	M3 x 6 Pan Hd. Screw	(2)
14	44-94-0650	Plunger Rod with Rod	(1)
15	-----	Barrel Tube Cover	(1)
16	-----	Barrel Spring	(1)
17	-----	Barrel	(1)
18	44-66-1525	Stamping Plate	(1)
19	45-06-0890	Rubber Seal	(1)
20	45-88-2030	Washer	(1)
21	-----	Spacer	(1)
22	44-86-1380	Retaining Ring	(1)
23	-----	Fuel Gauge	(1)
24	-----	Motor Pinion	(1)
25	31-50-2700	Housing Assembly Kit	(1)
26	44-86-1380	Retaining Ring	(1)
★27	05-81-1221	M4 x 12 Pan Hd. Screw	(3)

FIG.	PART NO.	DESCRIPTION OF PART	NO. REQ.
★28	14-29-0601	Gearcase Assembly	(1)
29	-----	Ball Bearing	(1)
30	-----	Output Shaft	(1)
31	-----	Crank Flange	(1)
32	42-40-0725	Bushing Assembly	(1)
33	45-88-0890	Washer	(1)
34	34-80-1200	Retaining Ring	(1)
35	45-98-0250	Yoke	(1)
★36	44-70-0701	Pump Body Kit	(1)
37	44-90-0600	Seal Ring	(1)
38	44-62-0325	Piston	(1)
39	31-15-0990	Yoke Cover	(1)
40	05-81-1260	M4 x 10 Pan Hd. Screw	(2)
41	05-85-0700	Hex Screw	(1)
42	34-40-0375	O-Ring	(1)
43	40-50-1660	Spring	(1)
44	42-42-1070	Air Release Button	(1)
45	02-02-0265	3/8" Ball	(1)
46	40-50-1685	Spring	(1)
47	45-88-0905	Copper Washer	(1)
48	45-04-1010	Plug Screw	(1)
49	43-44-1100	Rubber Gasket	(1)
50	30-06-0200	Barrel Assembly	(1)
51	06-82-2385	M2.6 x 14 Pan Hd. T-8 Screw	(2)
52	06-82-7470	6 x 11/16" Pan Hd. Plastite T-15 Screw	(5)
53	43-75-0500	Grease Hose Holster	(1)
54	05-81-1275	M4 x 20 Pan Hd. Taptite T-20 Screw	(1)
55	12-20-2446	Service Nameplate Kit	(1)
56	42-90-0575	Coupler Holster	(1)
57	06-82-7475	6 x 7/8" Pan Hd. Plastite T-15 Screw	(1)
58	42-90-0700	Coupler Assembly	(1)
59	14-37-0300	Grease Hose Assembly	(1)
61	23-66-2890	Switch Assembly	(1)
62	-----	Left Housing Halve	(1)
63	-----	Right Housing Halve	(1)
64	45-04-1030	Plug Screw Kit	(1)
65	42-42-1080	Air Release Kit	(1)
66	45-98-0300	Yoke Kit	(1)
67	42-40-1150	Bushing Kit	(1)
68	-----	Spring Washer	(1)
69	-----	Washer	(1)
70	42-55-2446	Soft Carrying Case	(1)
71	44-86-1400	Self-Locking Retaining Ring	(1)



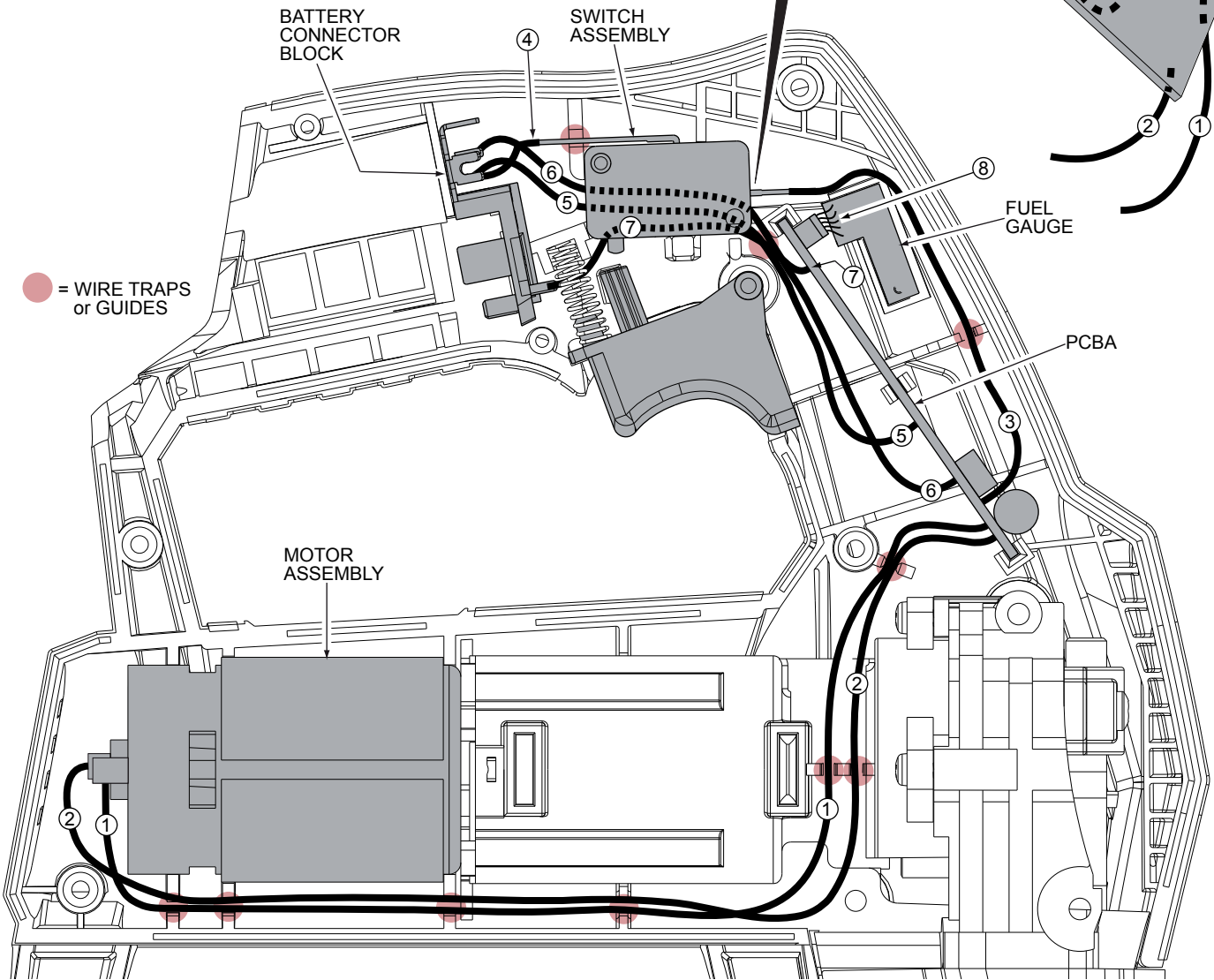
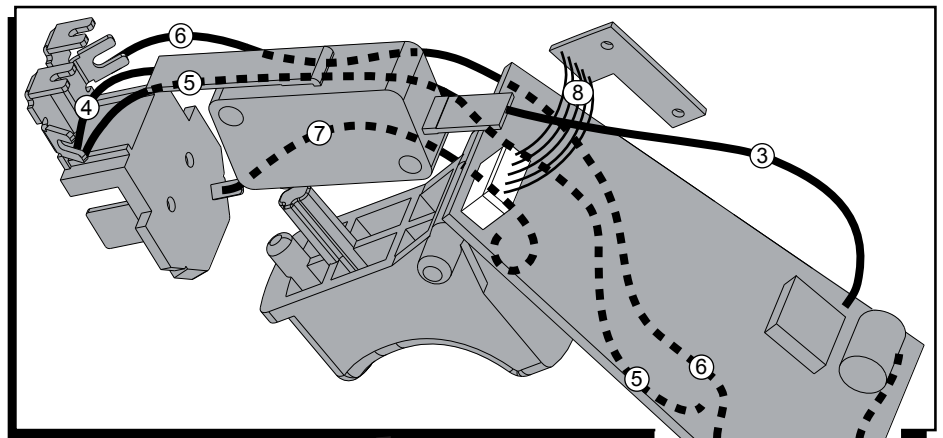

● = WIRE TRAPS or GUIDES

### WIRING SPECIFICATIONS

Wire No.	Wire Color	Origin or Gauge	Length	Terminals, Connectors and 1 or 2 End Wire Preparation
1	Red	----	----	Wire connects from PCBA to (+) right side of motor.
2	White	----	----	Wire connects from PCBA to (-) left side of motor.
3	Blue	----	----	Wire connects from PCBA to front of switch.
4	Red	----	----	Wire connects from connector block (with #5) to back of switch.
5	Red	----	----	Wire connects from PCBA to connector block (with #4).
6	Black	----	----	Wire connects from PCBA to connector block.
7	White	----	----	Wire connects from PCBA to connector block.
8	----	----	----	Fuel gauge harness plugs into PCBA.

AS AN AID TO REASSEMBLY, TAKE NOTICE OF WIRE ROUTING AND POSITION IN WIRE GUIDES AND TRAPS WHILE DISMANTLING TOOL.

BE CAREFUL AND AVOID PINCHING WIRES BETWEEN HANDLE HALVES WHEN ASSEMBLING.