



# SERVICE PARTS LIST

**BULLETIN NO.**  
**54-24-0179**

<b>SPECIFY CATALOG NO. AND SERIAL NO. WHEN ORDERING PARTS</b>		REVISED BULLETIN 54-24-0178	DATE July 2001
<b>1/2" REV. MAGNUM HAMMER-DRILL</b>			
<b>CATALOG NO.</b> 5374-1	<b>STARTING SERIAL NO.</b>	<b>715C</b>	
		<b>WIRING INSTRUCTION</b> <b>58-01-1650</b>	

**EXAMPLE:**  
Component Parts  
(Small #) Are Included  
When Ordering The  
Assembly (Large #).

★=Part number change from  
previous service parts list.

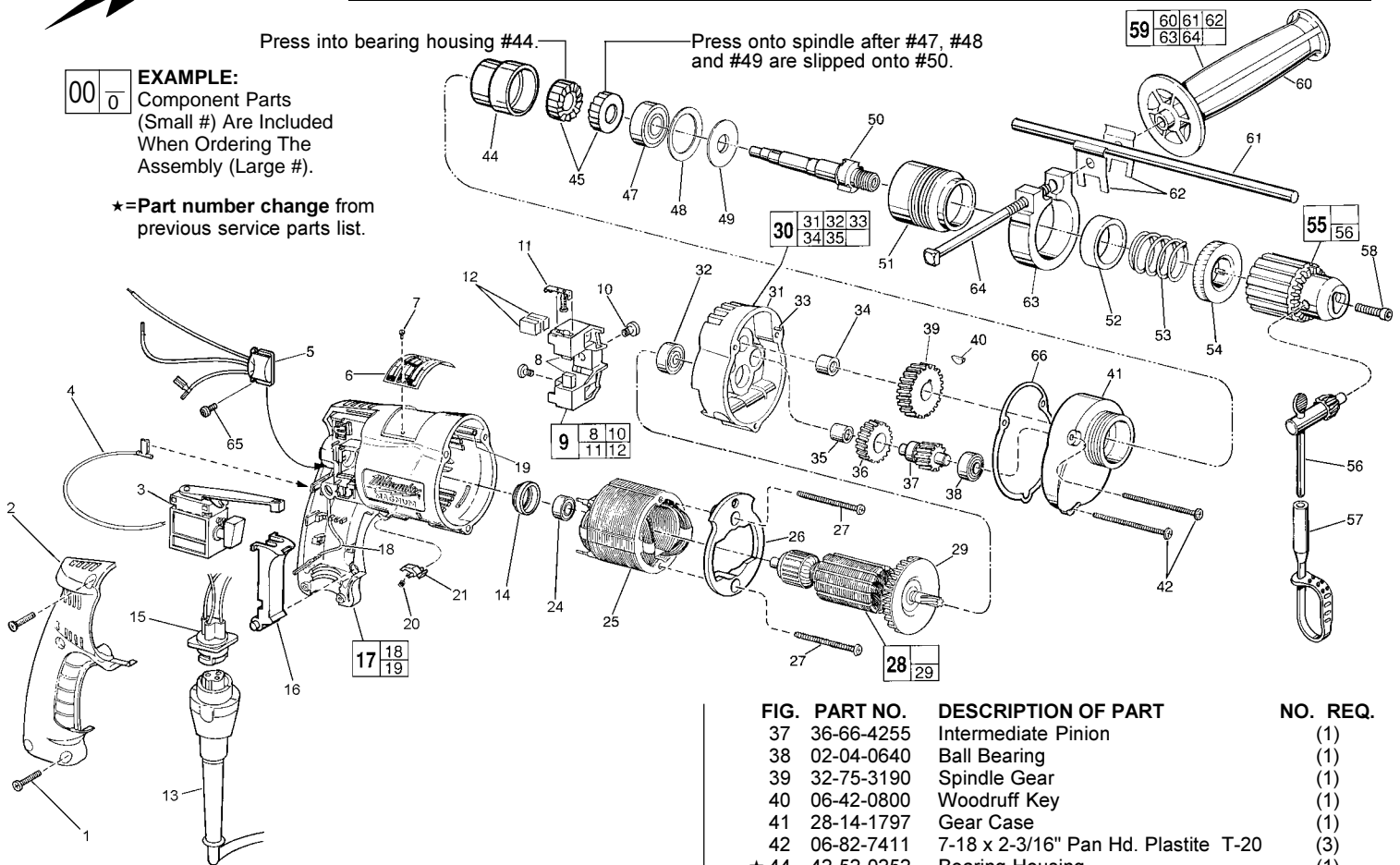

FIG.	PART NO.	DESCRIPTION OF PART	NO.	REQ.
1	06-82-7266	7-18 x 11/16" Plastite Screw T-20	(5)	
2	31-15-0402	Handle Cover	(1)	
3	23-66-1666	TSC Reversing Switch	(1)	
4	23-94-6247	2-1/4" Lead Assembly	(1)	
5	14-20-0795	Remote Electronic Assembly	(1)	
6	12-99-0225	Nameplate Blank	(1)	
7	06-72-1720	Nameplate Rivet	(2)	
8	22-16-0300	Carbon Brush	(2)	
9	22-22-0356	Brush Holder Assembly	(1)	
10	31-75-0040	Brush Holder Screw	(2)	
11	22-20-0355	Brush Spring Assembly	(2)	
12	22-16-0300	Carbon Brush (Spares)	(2)	
13	48-76-4008	8 Foot Quik-Lok Cord Set	(1)	
14	22-72-0100	Bearing Cup	(1)	
15	22-56-0807	Pin Housing Assembly	(1)	
16	45-72-0081	Trigger	(1)	
17	14-38-0540	Motor Housing Assembly	(1)	
18	23-94-9960	Ground Wire Assembly	(1)	
19	44-60-1290	Grounding Pin	(1)	
20	40-50-0085	Lock Button Spring	(1)	
21	42-42-0460	Lock Button	(1)	
24	02-04-0645	Ball Bearing	(1)	
25	18-11-0075	120 Volt Field	(1)	
26	42-14-0390	Baffle	(1)	
27	06-82-7398	7 -18 x 2-1/16" Pan Hd. Screw T-20	(2)	
28	16-10-0800	120 Volt Armature	(1)	
29	22-84-0880	Fan Assembly	(1)	
30	14-13-0497	Diaphragm Assembly	(1)	
31	-----	Diaphragm	(1)	
32	02-04-0847	Ball Bearing	(1)	
33	06-65-0880	Ground Pin	(1)	
34	02-50-2020	Needle Bearing	(1)	
35	02-50-1620	Needle Bearing	(1)	
36	32-40-1820	Intermediate Gear	(1)	

FIG.	PART NO.	DESCRIPTION OF PART	NO.	REQ.
37	36-66-4255	Intermediate Pinion	(1)	
38	02-04-0640	Ball Bearing	(1)	
39	32-75-3190	Spindle Gear	(1)	
40	06-42-0800	Woodruff Key	(1)	
41	28-14-1797	Gear Case	(1)	
42	06-82-7411	7-18 x 2-3/16" Pan Hd. Plastite T-20	(3)	
★ 44	42-52-0252	Bearing Housing	(1)	
★ 45	44-84-0295	Ratchet	(2)	
47	02-04-1536	Ball Bearing	(1)	
48	45-88-7350	Bearing Retainer Washer	(1)	
49	45-88-7365	Spring Support Washer	(1)	
★ 50	38-50-5577	Spindle	(1)	
51	45-22-0405	Sleeve (Left Hand Thread)	(1)	
52	45-88-7375	Felt Washer	(1)	
53	40-50-4950	Spring	(1)	
54	42-76-0200	Locking Collar	(1)	
55	48-66-1365	1/2" Reversing Chuck	(1)	
56	48-66-3280	Chuck Key	(1)	
57	48-66-4040	Key Holder	(1)	
58	06-75-3155	1/4-20 x 1" Socket Hd. Screw L.H. Thread	(1)	
59	14-34-0250	Side Handle Assembly	(1)	
60	43-62-0865	Side Handle	(1)	
61	44-94-0161	Depth Rod	(1)	
62	42-68-0390	Depth Gauge Clamp	(2)	
63	25-82-0140	Clamping Collar	(1)	
64	42-32-0161	5/16-18 x 3-1/2" Square Hd. Bolt	(1)	
65	06-82-7212	4-20 x 1/4" Pan Hd. Plastite T-10	(1)	
66	43-44-0913	Gasket	(1)	
	23-94-6232	4" Lead Assembly	(1)	
	23-94-6237	4-1/8" Lead Assembly	(1)	
	23-94-6242	3-3/8" Lead Assembly	(1)	
	10-98-5986	Warning Label	(1)	

**FIG. LUBRICATION**

- 41 1-1/2 Oz. Type "E" Grease, No. 49-08-4122.
- 45 Apply Thin Coat "U" Grease, No. 49-08-0150, To Ratchet Teeth.

**MILWAUKEE ELECTRIC TOOL CORPORATION**  
13135 W. LISBON RD., BROOKFIELD, WI 53005



# SERVICE PARTS LIST

**BULLETIN NO.**  
**54-24-0179**

<b>SPECIFY CATALOG NO. AND SERIAL NO. WHEN ORDERING PARTS</b>		REVISED BULLETIN 54-24-0178	DATE July 2001
<b>1/2" REV. MAGNUM HAMMER-DRILL</b>			
<b>CATALOG NO.</b> 5374-1	<b>STARTING SERIAL NO.</b>	<b>715C</b>	
		<b>WIRING INSTRUCTION</b> <b>58-01-1650</b>	

**EXAMPLE:**  
Component Parts  
(Small #) Are Included  
When Ordering The  
Assembly (Large #).

★=Part number change from  
previous service parts list.

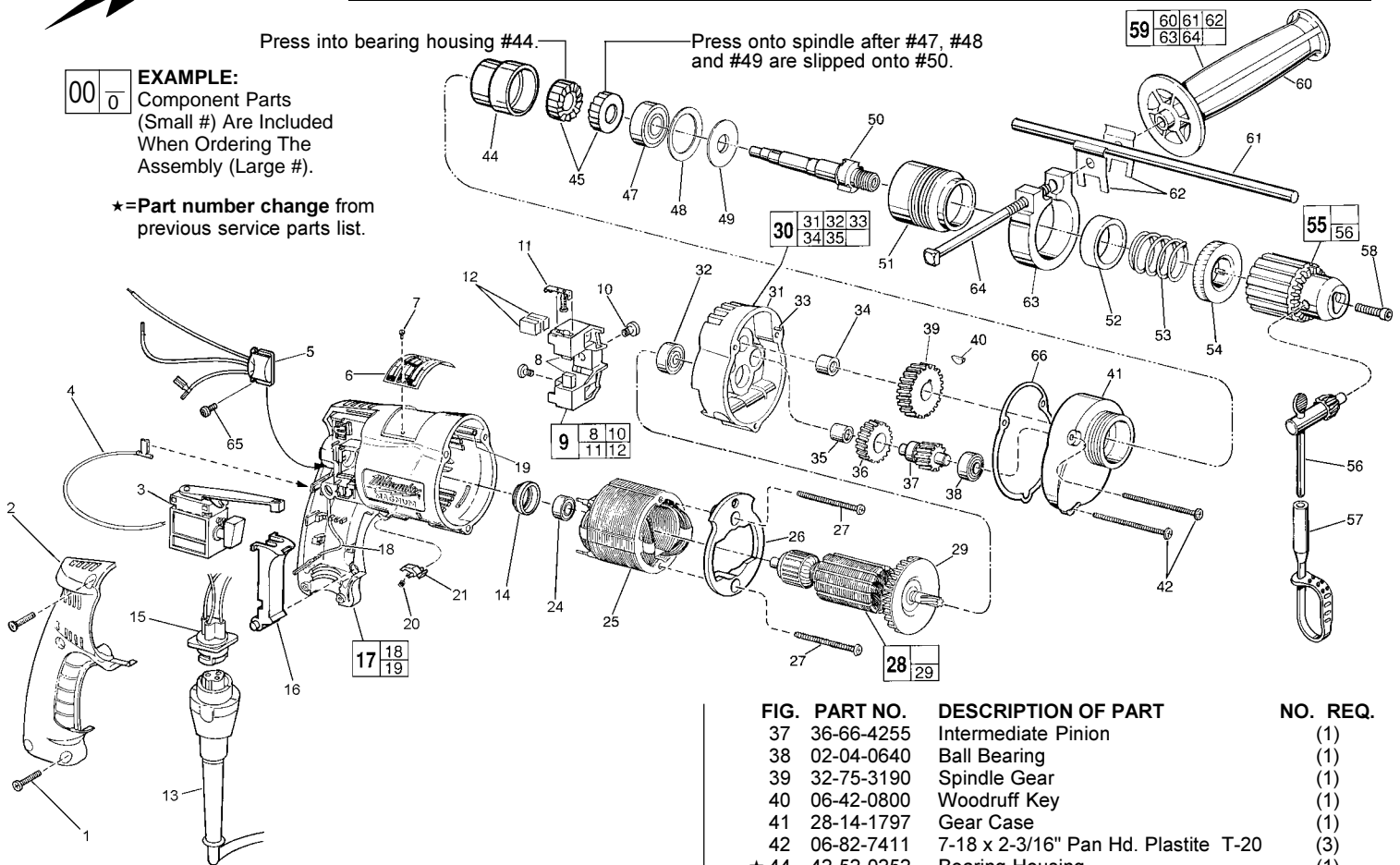

FIG.	PART NO.	DESCRIPTION OF PART	NO.	REQ.
1	06-82-7266	7-18 x 11/16" Plastite Screw T-20	(5)	
2	31-15-0402	Handle Cover	(1)	
3	23-66-1666	TSC Reversing Switch	(1)	
4	23-94-6247	2-1/4" Lead Assembly	(1)	
5	14-20-0795	Remote Electronic Assembly	(1)	
6	12-99-0225	Nameplate Blank	(1)	
7	06-72-1720	Nameplate Rivet	(2)	
8	22-16-0300	Carbon Brush	(2)	
9	22-22-0356	Brush Holder Assembly	(1)	
10	31-75-0040	Brush Holder Screw	(2)	
11	22-20-0355	Brush Spring Assembly	(2)	
12	22-16-0300	Carbon Brush (Spares)	(2)	
13	48-76-4008	8 Foot Quik-Lok Cord Set	(1)	
14	22-72-0100	Bearing Cup	(1)	
15	22-56-0807	Pin Housing Assembly	(1)	
16	45-72-0081	Trigger	(1)	
17	14-38-0540	Motor Housing Assembly	(1)	
18	23-94-9960	Ground Wire Assembly	(1)	
19	44-60-1290	Grounding Pin	(1)	
20	40-50-0085	Lock Button Spring	(1)	
21	42-42-0460	Lock Button	(1)	
24	02-04-0645	Ball Bearing	(1)	
25	18-11-0075	120 Volt Field	(1)	
26	42-14-0390	Baffle	(1)	
27	06-82-7398	7 -18 x 2-1/16" Pan Hd. Screw T-20	(2)	
28	16-10-0800	120 Volt Armature	(1)	
29	22-84-0880	Fan Assembly	(1)	
30	14-13-0497	Diaphragm Assembly	(1)	
31	-----	Diaphragm	(1)	
32	02-04-0847	Ball Bearing	(1)	
33	06-65-0880	Ground Pin	(1)	
34	02-50-2020	Needle Bearing	(1)	
35	02-50-1620	Needle Bearing	(1)	
36	32-40-1820	Intermediate Gear	(1)	

FIG.	PART NO.	DESCRIPTION OF PART	NO.	REQ.
37	36-66-4255	Intermediate Pinion	(1)	
38	02-04-0640	Ball Bearing	(1)	
39	32-75-3190	Spindle Gear	(1)	
40	06-42-0800	Woodruff Key	(1)	
41	28-14-1797	Gear Case	(1)	
42	06-82-7411	7-18 x 2-3/16" Pan Hd. Plastite T-20	(3)	
★ 44	42-52-0252	Bearing Housing	(1)	
★ 45	44-84-0295	Ratchet	(2)	
47	02-04-1536	Ball Bearing	(1)	
48	45-88-7350	Bearing Retainer Washer	(1)	
49	45-88-7365	Spring Support Washer	(1)	
★ 50	38-50-5577	Spindle	(1)	
51	45-22-0405	Sleeve (Left Hand Thread)	(1)	
52	45-88-7375	Felt Washer	(1)	
53	40-50-4950	Spring	(1)	
54	42-76-0200	Locking Collar	(1)	
55	48-66-1365	1/2" Reversing Chuck	(1)	
56	48-66-3280	Chuck Key	(1)	
57	48-66-4040	Key Holder	(1)	
58	06-75-3155	1/4-20 x 1" Socket Hd. Screw L.H. Thread	(1)	
59	14-34-0250	Side Handle Assembly	(1)	
60	43-62-0865	Side Handle	(1)	
61	44-94-0161	Depth Rod	(1)	
62	42-68-0390	Depth Gauge Clamp	(2)	
63	25-82-0140	Clamping Collar	(1)	
64	42-32-0161	5/16-18 x 3-1/2" Square Hd. Bolt	(1)	
65	06-82-7212	4-20 x 1/4" Pan Hd. Plastite T-10	(1)	
66	43-44-0913	Gasket	(1)	
	23-94-6232	4" Lead Assembly	(1)	
	23-94-6237	4-1/8" Lead Assembly	(1)	
	23-94-6242	3-3/8" Lead Assembly	(1)	
	10-98-5986	Warning Label	(1)	

**FIG. LUBRICATION**

- 41 1-1/2 Oz. Type "E" Grease, No. 49-08-4122.
- 45 Apply Thin Coat "U" Grease, No. 49-08-0150, To Ratchet Teeth.

**MILWAUKEE ELECTRIC TOOL CORPORATION**  
13135 W. LISBON RD., BROOKFIELD, WI 53005