

T12 Plastic-Coated, Shatter-Resistant Fluorescent **Black Lights**

Preheat T12 Fluorescent **Black Lights** Medium Bipin (5)

Nominal Lamp Watts	UPC/ Catalog Order#	Ordering Description	Std. Pkg. Qty.	Lamp Description	Nominal Length (Inches)	Avg. Life (Hours)	Bulb
20	23191I	F20T12/BL (6)	15	BLACK LIGHT (2)(5)	24	9,000	T12
	27201I	F20T12/BLB (6)	15	BLACK LIGHT BLUE (2)(5)	24	9,000	T12

Rapid Start T12 Fluorescent **Black Lights** Medium Bipin (5)

Nominal Lamp Watts	UPC/ Catalog Order#	Ordering Description	Std. Pkg. Qty.	Lamp Description	Nominal Length (Inches)	Avg. Life (Hours)	Bulb
40	30191I	F40T12/BL	15	BLACK LIGHT (2)(5)	48	20,000+	T12
	30200S	F40T12/BLB	15	BLACK LIGHT BLUE (2)(5)	48	20,000+	T12

T12 Plastic-Coated, Shatter-Resistant Fluorescent **Gold Lamps**

T12 Fluorescent **Gold Lamps** Medium Bipin & Single Pin

Nominal Lamp Watts	UPC/ Catalog Order#	Ordering Description	Std. Pkg. Qty.	Lamp Description	Nominal Length (Inches)	Avg. Life (Hours)	Mean Lumens
34	\$ 30039	F34T12/SRS/GOLD/ES/ALTO	30	RAPID START, ENERGY-SAVING	48	20,000	1,754
40	30259	F40T12/SRS/GOLD	30	RAPID START	48	20,000	2,170
56	40039	F72T12/SRS/GOLD	15	INSTANT START, SINGLE PIN	72	12,000	3,490
60	\$ 44039	F96T12/SRS/GOLD/ES	15	INSTANT START, SINGLE PIN	96	12,000	3,580
75	44259	F96T12/SRS/GOLD	15	INSTANT START, SINGLE PIN	96	12,000	4,361

T12 Plastic-Coated, Shatter-Resistant **U-Shaped** Fluorescent Lamps

U-Shaped T12 Fluorescent Lamps Medium Bipin with 6" Leg

Nominal Lamp Watts	UPC/ Catalog Order#	Ordering Description	Std. Pkg. Qty.	Lamp Description	Nominal Length (Inches)	Avg. Life (Hours)	Mean Lumens
40	Ⓔ 81490S	FB40T12/730/6	12	3000K, 6" LEG, 70 CRI	22 1/2	18,000	2,880
	Ⓔ 81500S	FB40T12/735/6	12	3500K, 6" LEG, 70 CRI	22 1/2	18,000	2,880
	Ⓔ 81270S	FB40T12/741/6	12	4100K, 6" LEG, 70 CRI	22 1/2	18,000	2,880
	Ⓔ 81520S	FB40T12/830/6	12	3000K, 6" LEG, 80 CRI	22 1/2	18,000	2,880
	81040S	FB40T12/CWX/6	12	4100K, 6" LEG, 87 CRI	22 1/2	18,000	2,880

Energy-Saving U-Shaped T12 Fluorescent Lamps Medium Bipin with 6" Leg

Nominal Lamp Watts	UPC/ Catalog Order#	Ordering Description	Std. Pkg. Qty.	Lamp Description	Nominal Length (Inches)	Avg. Life (Hours)	Mean Lumens
34	Ⓔ \$ 81491S	FB34T12/730/6/ES	12	3000K, 6" LEG, 70 CRI	22 1/2	18,000	2,457
	Ⓔ \$ 81501S	FB34T12/735/6/ES	12	3500K, 6" LEG, 70 CRI	22 1/2	18,000	2,457
	Ⓔ \$ 81511S	FB34T12/741/6/ES	12	4100K, 6" LEG, 70 CRI	22 1/2	18,000	2,457
	Ⓔ \$ 81011S	FB34T12/CW/6/ES	12	4200K, 6" LEG, 70 CRI	22 1/2	18,000	2,457
	Ⓔ \$ 81031S	FB34T12/WW/6/ES	12	3000K, 6" LEG, 70 CRI	22 1/2	18,000	2,457

\$ – Energy-Saving Product

Ⓜ – Features ALTO® Lamp Technology

Ⓔ – This bulb meets U.S. Federal minimum efficiency standards.

Footnotes located on page 28

ALTO® – Reduced Mercury Lamps

NOTE – Energy-Saving lamps are not intended for use in ambient temperatures below 60°F, in drafty locations, on low power factor ballasts, reduced current and light output ballasts, dimming ballasts, or on inventor powered emergency lighting systems. (3)

T5, T8 Plastic-Coated, Shatter-Resistant **UV / Germicidal Lamps**

UV / Germicidal Lamps T5 & T8

Nominal Lamp Watts	UPC/ Catalog Order#	Ordering Description	Std. Pkg. Qty.	Specifications	Length (mm)	Av. Life (Hours)	Base
				Amps Volts UV Output			
7.2	86905U	G8T5	6	.145 57 2.2	287	8,000	Min Bi-Pin
16	86906U	G16T5	6	.350 50 3.2	287	8,000	Min Bi-Pin
39	86911U	G36T5L	6	.424 115 13.0	846	9,000	Single Pin
	86912U	G36T5L/4P	6	.424 115 13.0	846	9,000	4-Pin
15	86907U	G15T8	6	.305 55 4.9	436	8,000	Med Bi-Pin
30.5	86906U	G30T8	6	.355 99 13.9	893	8,000	Med Bi-Pin



Fluorescent Lamps

Shat-R-Shield fluorescent lamps are coated from end-to-end with our exclusive, patented plastic coating. If a Shat-R-Shield lamp is dropped or broken, virtually all glass, phosphors and mercury are safely contained within the coating. Our coating reduces light output by less than 1% and is a minimum of 16 mils thick. Shat-R-Shield lamps are UL & NSF Certified, USDA approved, and meet FDA and OSHA standards. Lamps should not be installed in areas where ambient temperatures exceed 120°F. Shat-R-Shield linear fluorescent lamps are available in various wattages, colors and Kelvin temperatures, including T5, T8 & T12 sizes. Shat-R-Shield also offers many fluorescent lamps in ultraviolet (UV) blocking versions.

STANDARD -

In full wattage, energy-saving, preheat, rapid start & instant start linear versions.

HIGH OUTPUT (HO) -

Shat-R-Shield HO fluorescent lamps for non-refrigerated areas combine the heat-resistant properties of PFA with the strength of our highly-specialized coating (Refrigerated & Non-Refrigerated Areas).

VERY HIGH OUTPUT (VHO) -

Shat-R-Shield's plastics can reliably withstand the extreme temperatures emitted by a VHO fluorescent lamp (Refrigerated, Non-Refrigerated & Freezer Areas).

U-SHAPED -

The safest choice for 2' x 2' luminaries. These lamps can provide the same light output as a linear lamp of twice the length.

REDUCED MERCURY LAMPS -

With the lowest mercury content on the market, these lamps are manufactured to meet the Toxic Characteristic Leaching Procedure (TCLP) standards established by the U.S. EPA.

BLACK LIGHT & BLACK LIGHT BLUE -

Shat-R-Shield's black light coating utilizes ultraviolet stabilizers to prevent degradation of the coating while also allowing critical ultra-wavelengths to pass through for maximum insect control.

GOLD LAMPS -

These lamps block all ultraviolet and plus light emissions up to 530 nms. They are ideal for use in cleanroom environments, microchip production and all other photosensitive applications.

UV / GERMICIDAL LAMPS -

These lamps destroy microbes such as bacteria, viruses, molds and spores with high-output ultraviolet (UV-C) radiation. Germicidal lamps are perfect for use in HVAC and water treatment systems. This popular and effective method of decontamination is a physical process eliminating the need for toxic chemicals.



Base Types (Not Actual Sizes)

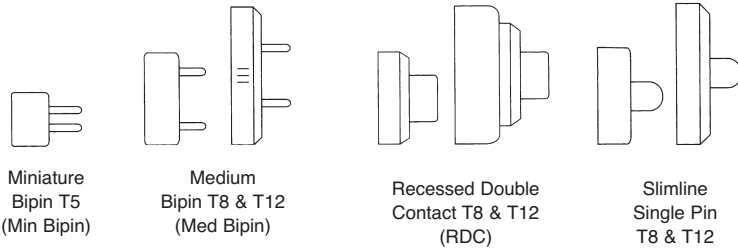

Bulb Shapes (Not Actual Sizes - Letters indicate the bulb shape while numbers indicate the diameter of the bulb in eighths of an inch.)

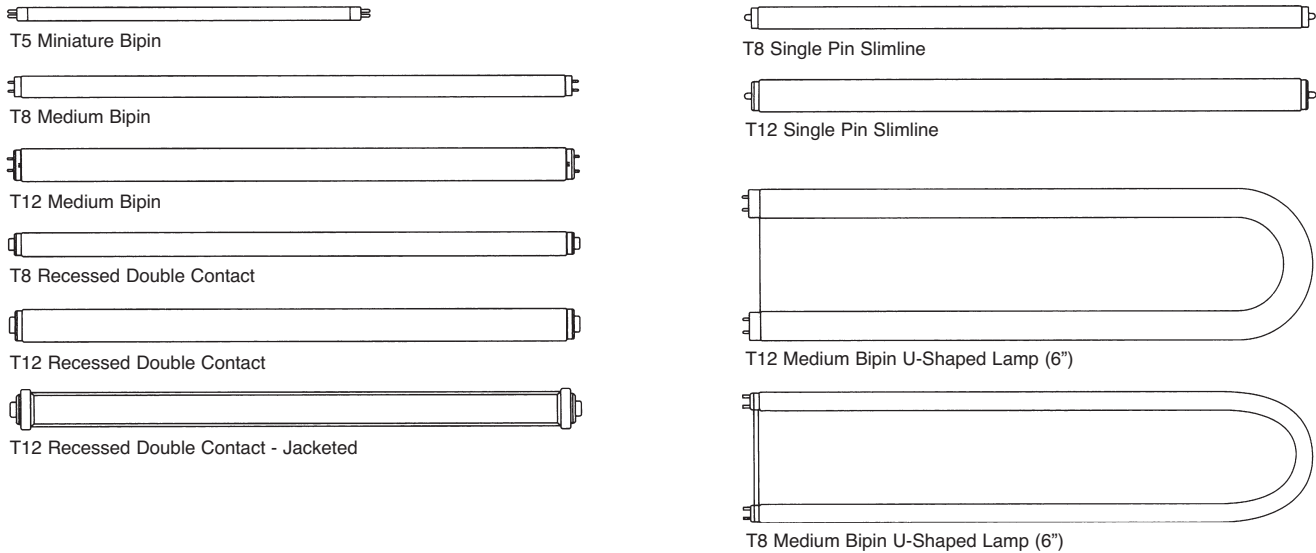

Protection From Ultraviolet (UV) Light

Antioxidants and ultraviolet stabilizers are present in the exclusive, clear plastic coating to block UV emissions from 180 to 390 nanometers. These additives also prevent the coating from yellowing, cracking or flaking. UV light causes the loss of vitamins and riboflavin which can negatively effect the taste of food and adds to food discoloration. UV can also cause the fading of colors or pigments in fabric and paper. Shat-R-Shield lamps are ideally suited for use in environments such as offices, retail/grocery stores, museums, galleries, computer chip industry and libraries.

Shat-R-Shield Fluorescent Lamp Warranty

The plastic coating on a Shat-R-Shield fluorescent is guaranteed to last for the rated-life of the lamp and will not turn yellow, crack or otherwise fail during that time, subject to the following conditions:

- The lamps can be installed in open or enclosed fixtures.
- T8 and T12 fluorescent lamps must be installed and operating in ambient temperatures below 150°F (400°F for T5HO lamps).
- The lamps cannot be used in fixtures employing defective ballasts, ballasts that have been used longer than their rated-life or ballasts that are improperly wired.
- The lamps cannot be used in fixtures where poor pin contact occurs.
- Lamp types and ballast types must be compatible (Rapid Start lamps with Rapid Start ballast, etc.).
- Shat-R-Shield, Inc. reserves the right to have an employee or agent inspect the fixture, ballast and/or location where a lamp with a failed coating was installed.
- Additional warranty coverage is provided by Osram/Sylvania® Quick 60+ and Philips Advantage® Plus 90 programs -- call Shat-R-Shield for details.

Shat-R-Shield, Inc. fluorescent lamps sold for use in refrigerated areas only are designated as such by a label on the lamp stating "REFRIGERATION USE ONLY" and are not covered by this guarantee. Because Shat-R-Shield has no control over the temperature range in the areas where lamps are operated, their performance cannot be guaranteed. Note that if used in temperatures below 45°F, the coating should be expected to last for the rated-life of the lamp.

Glossary of Terms

Average Life (Hours)

Under specified test conditions with lamps turned off and on no more often than once every three burning hours. Lamp life is appreciably longer if lamps are started less frequently.

Color Temperature (CT)

The overall color appearance of the light itself. Lamps range from 2100-7500 Kelvin. Lower color temperature (3000K) represents "warm" light, higher (4100K) represents "cool" light.

Color Rendering Index (CRI)

Color rendering is the ability of a light source to produce color in objects. The CRI is expressed on a scale from 0-100, where 100 is best in producing more natural color in objects.

Initial Lumens

Lumen value at 100 hours of burn time.

Instant Start

A circuit used to start specially-designed fluorescent lamps without the aid of a starter. This circuit is used today in slim-line and cold cathode lamps.

Light

The energy that allows us to see. Professionally, light can be expressed in four terms: 1) Intensity (candela), 2) Flux (lumen), 3) Luminance (candela/sq. ft.) and 4) Exitance (lumen/sq. ft.).

Lumen

The unit of measure for the light energy which flows in air. The total light output from electric sources is expressed in lumens.

Lumen Maintenance

The decrease of the lumen output of a light source over time.

Mean Lumens

Mean lumens are the approximate lamp lumen output at 40% of the lamp's Rated Average Life.

Nominal Length

A measurement of fluorescent lamp length based on the length of the lamp plus the proper allowance for standard lamp holders.

Preheat

A circuit used in fluorescent lamps where in the electrodes are heated or warmed to a glow stage by an auxilliary switch or starter before the lamps are lighted. This system was used on the original fluorescent lamps and is still in use today.

Rapid Start

A circuit designed to start lamps by continuously heating or preheating the electrodes. This circuit is a modern version of the trigger start system and requires lamps designed for this circuit. Except for slimline lamps, all modern fixtures using 40-watt and higher lamps are equipped with rapid start ballasts.

Rated Average Life

The operating life (hours) at which 50% of the lamps are still operating. Where a (+) is used in stating the life, survival rate is 67% at the stated time.

Watt

Unit used to measure power consumption of lamp.

Footnotes

- (1) The pins of these lamps are short circuited inside the end caps and lamp will not operate on preheat or rapid start ballast circuits.
 - (2) Designed for service other than illumination.
 - (3) Energy-saving lamps are only recommended for use on high power factor lead, indoor ballasts that meet ANSI standards. The lamps are not recommended for use in drafty areas, or locations where the ambient temperature is less than 60°F, except as noted. They should not be operated on low power factor ballasts, reduced light or reduced current ballasts, dimming ballasts or emergency system inverter ballasts.
 - (4) These lamps do not use PFA to seal the cathode ends as T-8 lamps with the PFA/Shat-R-Kote Combination. While less expensive, these lamps IF NOT USED ON ELECTRONIC BALLAST MUST BE USED IN REFRIGERATED AREAS WHERE AMBIENT TEMPERATURES DO NOT EXCEED 45°F. Due to the high heat generated at the cathode ends, any use of these lamps in conditions above 45°F may cause deterioration of the protective coating. Conversely, T-8 lamps used in freezing temperatures will not operate efficiently, coated or uncoated. Because Shat-R-Shield, Inc. has no control over the temperature range in the areas where lamps are operated, their performance cannot be guaranteed. However, T-8 lamps for refrigerated areas are being used in refrigerated areas with apparent success and can be expected to perform as well as other Shat-R-Shield lamps.
 - (5) When used in insect electrocutors, we recommend replacement of lamps after 7,000 hours of use because the black light in a coated or uncoated lamp deteriorates at a predictable rate. After 7,000 hours, the lamp's ability to attract insects is ineffective.
 - (6) Appliance lamp – for use with starters.
 - (7) To be operated on electronic ballasts.
- Ⓔ – These lamps comply with United States federal energy efficiency requirements.

T12 Plastic-Coated, Shatter-Resistant Fluorescent **Black Lights**

Preheat T12 Fluorescent **Black Lights** Medium Bipin (5)

Nominal Lamp Watts	UPC/ Catalog Order#	Ordering Description	Std. Pkg. Qty.	Lamp Description	Nominal Length (Inches)	Avg. Life (Hours)	Bulb
20	23191I	F20T12/BL (6)	15	BLACK LIGHT (2)(5)	24	9,000	T12
	27201I	F20T12/BLB (6)	15	BLACK LIGHT BLUE (2)(5)	24	9,000	T12

Rapid Start T12 Fluorescent **Black Lights** Medium Bipin (5)

Nominal Lamp Watts	UPC/ Catalog Order#	Ordering Description	Std. Pkg. Qty.	Lamp Description	Nominal Length (Inches)	Avg. Life (Hours)	Bulb
40	30191I	F40T12/BL	15	BLACK LIGHT (2)(5)	48	20,000+	T12
	30200S	F40T12/BLB	15	BLACK LIGHT BLUE (2)(5)	48	20,000+	T12

T12 Plastic-Coated, Shatter-Resistant Fluorescent **Gold Lamps**

T12 Fluorescent **Gold Lamps** Medium Bipin & Single Pin

Nominal Lamp Watts	UPC/ Catalog Order#	Ordering Description	Std. Pkg. Qty.	Lamp Description	Nominal Length (Inches)	Avg. Life (Hours)	Mean Lumens
34	\$ 30039	F34T12/SRS/GOLD/ES/ALTO	30	RAPID START, ENERGY-SAVING	48	20,000	1,754
40	30259	F40T12/SRS/GOLD	30	RAPID START	48	20,000	2,170
56	40039	F72T12/SRS/GOLD	15	INSTANT START, SINGLE PIN	72	12,000	3,490
60	\$ 44039	F96T12/SRS/GOLD/ES	15	INSTANT START, SINGLE PIN	96	12,000	3,580
75	44259	F96T12/SRS/GOLD	15	INSTANT START, SINGLE PIN	96	12,000	4,361

T12 Plastic-Coated, Shatter-Resistant **U-Shaped** Fluorescent Lamps

U-Shaped T12 Fluorescent Lamps Medium Bipin with 6" Leg

Nominal Lamp Watts	UPC/ Catalog Order#	Ordering Description	Std. Pkg. Qty.	Lamp Description	Nominal Length (Inches)	Avg. Life (Hours)	Mean Lumens
40	ⓔ 81490S	FB40T12/730/6	12	3000K, 6" LEG, 70 CRI	22 1/2	18,000	2,880
	ⓔ 81500S	FB40T12/735/6	12	3500K, 6" LEG, 70 CRI	22 1/2	18,000	2,880
	ⓔ 81270S	FB40T12/741/6	12	4100K, 6" LEG, 70 CRI	22 1/2	18,000	2,880
	ⓔ 81520S	FB40T12/830/6	12	3000K, 6" LEG, 80 CRI	22 1/2	18,000	2,880
	81040S	FB40T12/CWX/6	12	4100K, 6" LEG, 87 CRI	22 1/2	18,000	2,880

Energy-Saving U-Shaped T12 Fluorescent Lamps Medium Bipin with 6" Leg

Nominal Lamp Watts	UPC/ Catalog Order#	Ordering Description	Std. Pkg. Qty.	Lamp Description	Nominal Length (Inches)	Avg. Life (Hours)	Mean Lumens
34	ⓔ \$ 81491S	FB34T12/730/6/ES	12	3000K, 6" LEG, 70 CRI	22 1/2	18,000	2,457
	ⓔ \$ 81501S	FB34T12/735/6/ES	12	3500K, 6" LEG, 70 CRI	22 1/2	18,000	2,457
	ⓔ \$ 81511S	FB34T12/741/6/ES	12	4100K, 6" LEG, 70 CRI	22 1/2	18,000	2,457
	ⓔ \$ 81011S	FB34T12/CW/6/ES	12	4200K, 6" LEG, 70 CRI	22 1/2	18,000	2,457
	ⓔ \$ 81031S	FB34T12/WW/6/ES	12	3000K, 6" LEG, 70 CRI	22 1/2	18,000	2,457

\$ – Energy-Saving Product

ⓔ – Features ALTO® Lamp Technology

ⓔ – This bulb meets U.S. Federal minimum efficiency standards.

Footnotes located on page 28

ALTO® – Reduced Mercury Lamps

NOTE – Energy-Saving lamps are not intended for use in ambient temperatures below 60°F, in drafty locations, on low power factor ballasts, reduced current and light output ballasts, dimming ballasts, or on inventor powered emergency lighting systems. (3)

T5, T8 Plastic-Coated, Shatter-Resistant **UV / Germicidal Lamps**

UV / Germicidal Lamps T5 & T8

Nominal Lamp Watts	UPC/ Catalog Order#	Ordering Description	Std. Pkg. Qty.	Specifications	Length (mm)	Av. Life (Hours)	Base
				Amps Volts UV Output			
7.2	86905U	G8T5	6	.145 57 2.2	287	8,000	Min Bi-Pin
16	86906U	G16T5	6	.350 50 3.2	287	8,000	Min Bi-Pin
39	86911U	G36T5L	6	.424 115 13.0	846	9,000	Single Pin
	86912U	G36T5L/4P	6	.424 115 13.0	846	9,000	4-Pin
15	86907U	G15T8	6	.305 55 4.9	436	8,000	Med Bi-Pin
30.5	86906U	G30T8	6	.355 99 13.9	893	8,000	Med Bi-Pin



Fluorescent Lamps

Shat-R-Shield fluorescent lamps are coated from end-to-end with our exclusive, patented plastic coating. If a Shat-R-Shield lamp is dropped or broken, virtually all glass, phosphors and mercury are safely contained within the coating. Our coating reduces light output by less than 1% and is a minimum of 16 mils thick. Shat-R-Shield lamps are UL & NSF Certified, USDA approved, and meet FDA and OSHA standards. Lamps should not be installed in areas where ambient temperatures exceed 120°F. Shat-R-Shield linear fluorescent lamps are available in various wattages, colors and Kelvin temperatures, including T5, T8 & T12 sizes. Shat-R-Shield also offers many fluorescent lamps in ultraviolet (UV) blocking versions.

STANDARD -

In full wattage, energy-saving, preheat, rapid start & instant start linear versions.

HIGH OUTPUT (HO) -

Shat-R-Shield HO fluorescent lamps for non-refrigerated areas combine the heat-resistant properties of PFA with the strength of our highly-specialized coating (Refrigerated & Non-Refrigerated Areas).

VERY HIGH OUTPUT (VHO) -

Shat-R-Shield's plastics can reliably withstand the extreme temperatures emitted by a VHO fluorescent lamp (Refrigerated, Non-Refrigerated & Freezer Areas).

U-SHAPED -

The safest choice for 2' x 2' luminaries. These lamps can provide the same light output as a linear lamp of twice the length.

REDUCED MERCURY LAMPS -

With the lowest mercury content on the market, these lamps are manufactured to meet the Toxic Characteristic Leaching Procedure (TCLP) standards established by the U.S. EPA.

BLACK LIGHT & BLACK LIGHT BLUE -

Shat-R-Shield's black light coating utilizes ultraviolet stabilizers to prevent degradation of the coating while also allowing critical ultra-wavelengths to pass through for maximum insect control.

GOLD LAMPS -

These lamps block all ultraviolet and plus light emissions up to 530 nms. They are ideal for use in cleanroom environments, microchip production and all other photosensitive applications.

UV / GERMICIDAL LAMPS -

These lamps destroy microbes such as bacteria, viruses, molds and spores with high-output ultraviolet (UV-C) radiation. Germicidal lamps are perfect for use in HVAC and water treatment systems. This popular and effective method of decontamination is a physical process eliminating the need for toxic chemicals.



Base Types (Not Actual Sizes)

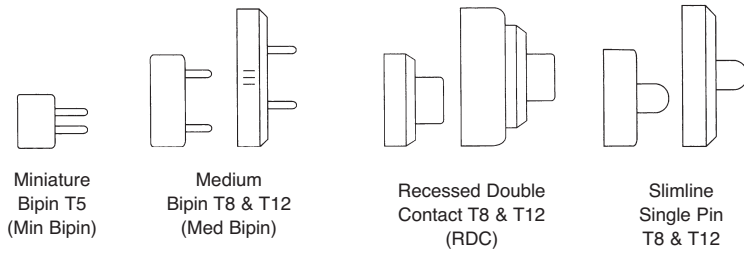

Bulb Shapes (Not Actual Sizes - Letters indicate the bulb shape while numbers indicate the diameter of the bulb in eighths of an inch.)

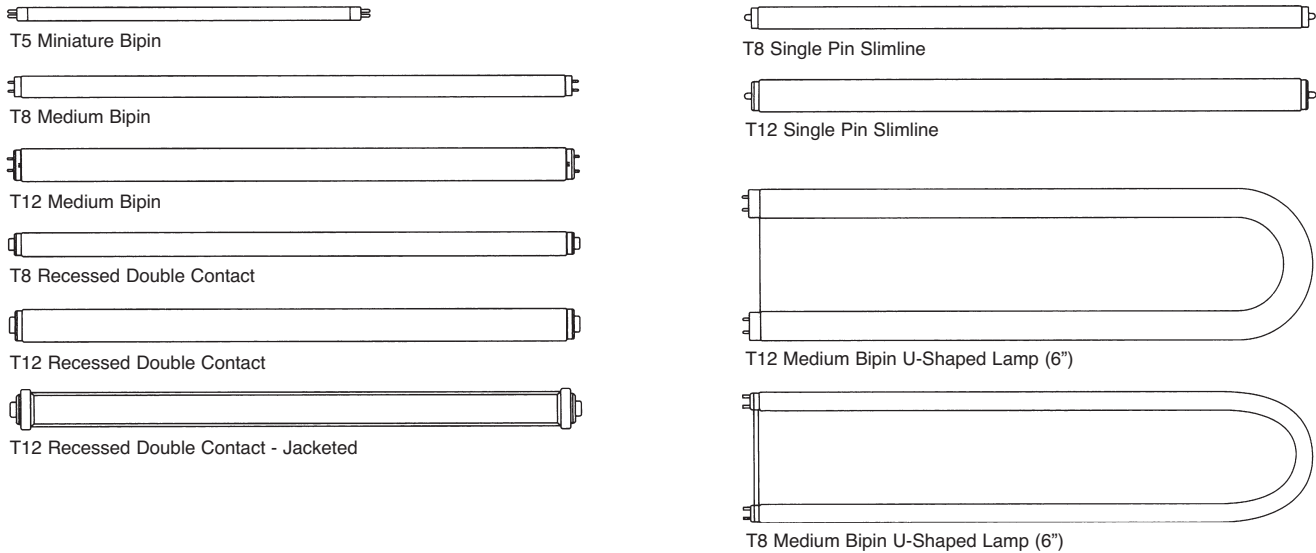

Protection From Ultraviolet (UV) Light

Antioxidants and ultraviolet stabilizers are present in the exclusive, clear plastic coating to block UV emissions from 180 to 390 nanometers. These additives also prevent the coating from yellowing, cracking or flaking. UV light causes the loss of vitamins and riboflavin which can negatively effect the taste of food and adds to food discoloration. UV can also cause the fading of colors or pigments in fabric and paper. Shat-R-Shield lamps are ideally suited for use in environments such as offices, retail/grocery stores, museums, galleries, computer chip industry and libraries.

Shat-R-Shield Fluorescent Lamp Warranty

The plastic coating on a Shat-R-Shield fluorescent is guaranteed to last for the rated-life of the lamp and will not turn yellow, crack or otherwise fail during that time, subject to the following conditions:

- The lamps can be installed in open or enclosed fixtures.
- T8 and T12 fluorescent lamps must be installed and operating in ambient temperatures below 150°F (400°F for T5HO lamps).
- The lamps cannot be used in fixtures employing defective ballasts, ballasts that have been used longer than their rated-life or ballasts that are improperly wired.
- The lamps cannot be used in fixtures where poor pin contact occurs.
- Lamp types and ballast types must be compatible (Rapid Start lamps with Rapid Start ballast, etc.).
- Shat-R-Shield, Inc. reserves the right to have an employee or agent inspect the fixture, ballast and/or location where a lamp with a failed coating was installed.
- Additional warranty coverage is provided by Osram/Sylvania® Quick 60+ and Philips Advantage® Plus 90 programs -- call Shat-R-Shield for details.

Shat-R-Shield, Inc. fluorescent lamps sold for use in refrigerated areas only are designated as such by a label on the lamp stating "REFRIGERATION USE ONLY" and are not covered by this guarantee. Because Shat-R-Shield has no control over the temperature range in the areas where lamps are operated, their performance cannot be guaranteed. Note that if used in temperatures below 45°F, the coating should be expected to last for the rated-life of the lamp.

Glossary of Terms

Average Life (Hours)

Under specified test conditions with lamps turned off and on no more often than once every three burning hours. Lamp life is appreciably longer if lamps are started less frequently.

Color Temperature (CT)

The overall color appearance of the light itself. Lamps range from 2100-7500 Kelvin. Lower color temperature (3000K) represents "warm" light, higher (4100K) represents "cool" light.

Color Rendering Index (CRI)

Color rendering is the ability of a light source to produce color in objects. The CRI is expressed on a scale from 0-100, where 100 is best in producing more natural color in objects.

Initial Lumens

Lumen value at 100 hours of burn time.

Instant Start

A circuit used to start specially-designed fluorescent lamps without the aid of a starter. This circuit is used today in slim-line and cold cathode lamps.

Light

The energy that allows us to see. Professionally, light can be expressed in four terms: 1) Intensity (candela), 2) Flux (lumen), 3) Luminance (candela/sq. ft.) and 4) Exitance (lumen/sq. ft.).

Lumen

The unit of measure for the light energy which flows in air. The total light output from electric sources is expressed in lumens.

Lumen Maintenance

The decrease of the lumen output of a light source over time.

Mean Lumens

Mean lumens are the approximate lamp lumen output at 40% of the lamp's Rated Average Life.

Nominal Length

A measurement of fluorescent lamp length based on the length of the lamp plus the proper allowance for standard lamp holders.

Preheat

A circuit used in fluorescent lamps where in the electrodes are heated or warmed to a glow stage by an auxilliary switch or starter before the lamps are lighted. This system was used on the original fluorescent lamps and is still in use today.

Rapid Start

A circuit designed to start lamps by continuously heating or preheating the electrodes. This circuit is a modern version of the trigger start system and requires lamps designed for this circuit. Except for slimline lamps, all modern fixtures using 40-watt and higher lamps are equipped with rapid start ballasts.

Rated Average Life

The operating life (hours) at which 50% of the lamps are still operating. Where a (+) is used in stating the life, survival rate is 67% at the stated time.

Watt

Unit used to measure power consumption of lamp.

Footnotes

- (1) The pins of these lamps are short circuited inside the end caps and lamp will not operate on preheat or rapid start ballast circuits.
 - (2) Designed for service other than illumination.
 - (3) Energy-saving lamps are only recommended for use on high power factor lead, indoor ballasts that meet ANSI standards. The lamps are not recommended for use in drafty areas, or locations where the ambient temperature is less than 60°F, except as noted. They should not be operated on low power factor ballasts, reduced light or reduced current ballasts, dimming ballasts or emergency system inverter ballasts.
 - (4) These lamps do not use PFA to seal the cathode ends as T-8 lamps with the PFA/Shat-R-Kote Combination. While less expensive, these lamps IF NOT USED ON ELECTRONIC BALLAST MUST BE USED IN REFRIGERATED AREAS WHERE AMBIENT TEMPERATURES DO NOT EXCEED 45°F. Due to the high heat generated at the cathode ends, any use of these lamps in conditions above 45°F may cause deterioration of the protective coating. Conversely, T-8 lamps used in freezing temperatures will not operate efficiently, coated or uncoated. Because Shat-R-Shield, Inc. has no control over the temperature range in the areas where lamps are operated, their performance cannot be guaranteed. However, T-8 lamps for refrigerated areas are being used in refrigerated areas with apparent success and can be expected to perform as well as other Shat-R-Shield lamps.
 - (5) When used in insect electrocutors, we recommend replacement of lamps after 7,000 hours of use because the black light in a coated or uncoated lamp deteriorates at a predictable rate. After 7,000 hours, the lamp's ability to attract insects is ineffective.
 - (6) Appliance lamp – for use with starters.
 - (7) To be operated on electronic ballasts.
- Ⓔ – These lamps comply with United States federal energy efficiency requirements.