

Schedule 40 / Schedule 80 Fittings & Accessories

Expansion Couplings - One Piece

Part Number	Trade Size	Carton Qty.	"W"	"L"	Travel Length
5144026	1/2	50	1.000	5.813	4.000
5144015	3/4	50	1.313	6.375	4.000
5144016	1	50	1.563	6.750	5.000
5144017	1-1/4	25	2.000	7.250	5.000
5144018	1-1/2	25	2.188	7.438	5.000
5144019	2	25	2.688	8.438	6.000
5144020	2-1/2	5	3.188	8.875	6.000
5144021	3	10	4.000	9.250	6.000
5144023	4	5	5.000	10.000	7.000

Dimensions are nominal

1/2" through 3/4" Maximum Expansion - 4"	2" through 3" Maximum Expansion - 6"
1" through 1-1/2" Maximum Expansion - 5"	3-1/2" through 4" Maximum Expansion - 7"

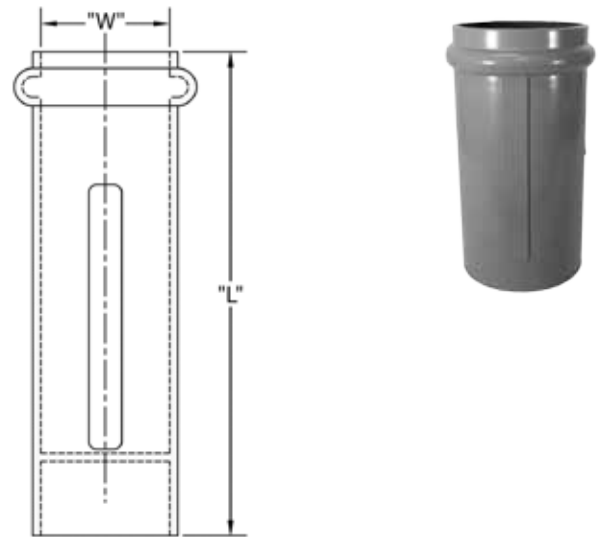

Expansion Couplings - Two Piece

Part Number	Trade Size	Carton Qty.	"A"	"B"	"C"	"D"
5144031	1/2	25	.875	7.000	.688	8.125
5144032	3/4	10	1.063	7.000	.875	8.125
5144033	1	10	1.313	7.063	1.000	8.375
5144034	1-1/4	5	1.688	7.625	1.000	9.000
5144035	1-1/2	5	1.938	7.563	1.125	9.000
5144036	2	25	2.375	7.688	1.188	9.250
5144037	*2-1/2	12	2.875	12.000	1.875	14.938
5144038	3	12	3.500	12.000	1.875	14.938
5144039	*3-1/2	6	4.000	12.375	2.000	14.875
5144040	4	6	4.500	12.313	2.125	14.875
**5144041	*5	1	5.563	19.250	2.938	24.000
**5144042	*6	1	6.625	20.813	3.000	26.375

* Not UL Listed ** Fabricated

Dimensions are nominal

1/2" through 2" Maximum Expansion - 4"	2-1/2" through 6" Maximum Expansion - 8"
---	---

A two piece coupling with solvent weld bells in each end. The spigot part of the joint slides through an internal o-ring to compensate for temperature changes.

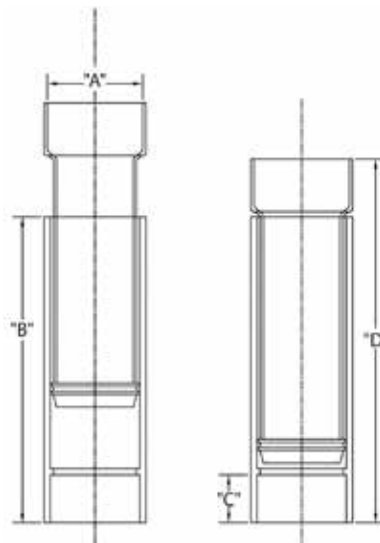

Schedule 40 / Schedule 80 Fittings & Accessories

Expansion Couplings - One Piece

Part Number	Trade Size	Carton Qty.	"W"	"L"	Travel Length
5144026	1/2	50	1.000	5.813	4.000
5144015	3/4	50	1.313	6.375	4.000
5144016	1	50	1.563	6.750	5.000
5144017	1-1/4	25	2.000	7.250	5.000
5144018	1-1/2	25	2.188	7.438	5.000
5144019	2	25	2.688	8.438	6.000
5144020	2-1/2	5	3.188	8.875	6.000
5144021	3	10	4.000	9.250	6.000
5144023	4	5	5.000	10.000	7.000

Dimensions are nominal

1/2" through 3/4"	2" through 3"
Maximum Expansion - 4"	Maximum Expansion - 6"
1" through 1-1/2"	3-1/2" through 4"
Maximum Expansion - 5"	Maximum Expansion - 7"

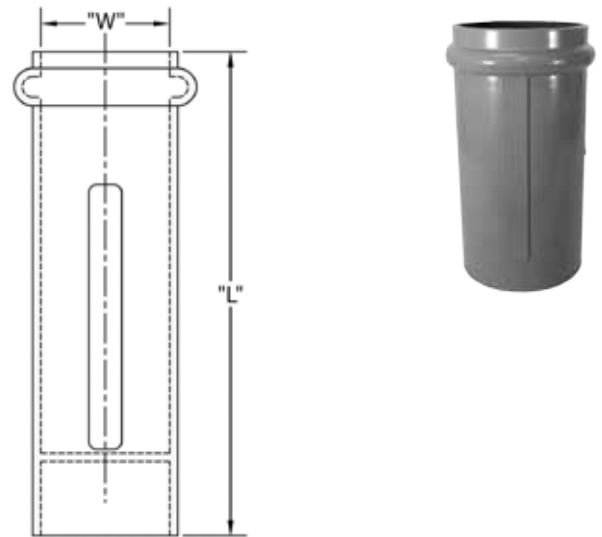

Expansion Couplings - Two Piece

Part Number	Trade Size	Carton Qty.	"A"	"B"	"C"	"D"
5144031	1/2	25	.875	7.000	.688	8.125
5144032	3/4	10	1.063	7.000	.875	8.125
5144033	1	10	1.313	7.063	1.000	8.375
5144034	1-1/4	5	1.688	7.625	1.000	9.000
5144035	1-1/2	5	1.938	7.563	1.125	9.000
5144036	2	25	2.375	7.688	1.188	9.250
5144037	*2-1/2	12	2.875	12.000	1.875	14.938
5144038	3	12	3.500	12.000	1.875	14.938
5144039	*3-1/2	6	4.000	12.375	2.000	14.875
5144040	4	6	4.500	12.313	2.125	14.875
**5144041	*5	1	5.563	19.250	2.938	24.000
**5144042	*6	1	6.625	20.813	3.000	26.375

* Not UL Listed ** Fabricated

Dimensions are nominal

1/2" through 2"	2-1/2" through 6"
Maximum Expansion - 4"	Maximum Expansion - 8"

A two piece coupling with solvent weld bells in each end. The spigot part of the joint slides through an internal o-ring to compensate for temperature changes.

