

DESCRIPTION

Reduces the sound level of your existing bath fan by up to 50% while increasing air movement by up to 20%. No rewiring or new ductwork required.

GRILLE:

- White polymeric - blends well with any decor
- Torsion spring grille mounting - no tools required

FAN ASSEMBLY:

- Plug-in, permanently lubricated motor
- Polymeric blower wheel
- Galvanized steel motor bracket and motor plate
- Fits into your existing bath fan housing
- Two motor plate sizes included - to accommodate a variety of economy fan models

ACCESSORIES:

- Wrench and hardware included - no additional tools required
- Polymeric scroll band included - enhances performance of existing bath fan housings

SPECIFICATIONS

VOLTS	AMPS	CFM	SONES
120	1.2	60	3.0



HVI-2100 CERTIFIED RATINGS comply with new testing technologies and procedures prescribed by the Home Ventilating Institute, for off-the-shelf products, as they are available to consumers. Product performance is rated at 0.1 in. static pressure, based on tests conducted in AMCA's state-of-the-art test laboratory. Sones are a measure of humanly-perceived loudness, based on laboratory measurements.

For use only with these bath fan models:



NuTone 693, 695, 696N

The kit will work if your housing measures either 7½" x 7¼" or 8" x 7¼".



Broan 670, 671, 688, 689

The kit will work if your housing measures 7½" x 7¼".



Nautilus N671, N688

The kit will work if your housing measures 7½" x 7¼".

INSTALLATION

Complete installation instructions are included with each kit.

Bath Fan Upgrade Kit

MODEL 690NT

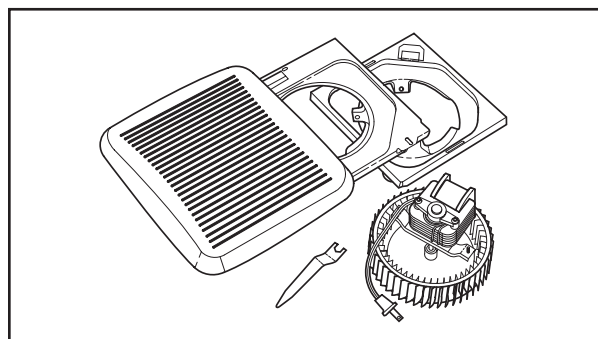

ARCHITECT'S SPECIFICATION

- Bath Fan Upgrade Kit shall be NuTone Model 690NT.
- Bath Fan Upgrade Kit shall include two galvanized steel motor plates designed to accommodate a variety of economy fan models.
- Motor shall be removable and permanently lubricated.
- Air delivery shall be no less than 60 cfm and sound level no greater than 3.0 Sones. All air and sound ratings shall be certified by HVI. Unit shall be U.L. Listed.

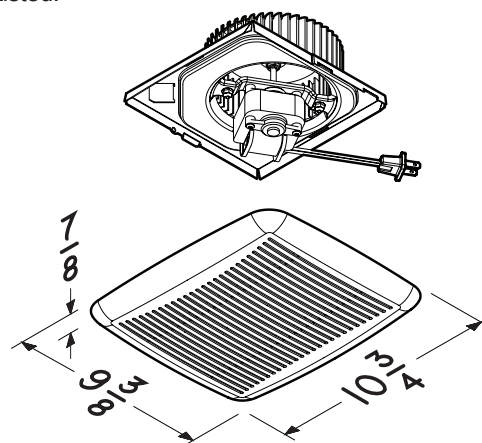

NuTone, Inc., 4820 Red Bank Road, Cincinnati, OH 45227 (1-800-543-8687)

REFERENCE	QTY.	REMARKS	Project
			Location
			Architect
			Engineer
			Contractor
			Submitted by Date

DESCRIPTION

Reduces the sound level of your existing bath fan by up to 50% while increasing air movement by up to 20%. No rewiring or new ductwork required.

GRILLE:

- White polymeric - blends well with any decor
- Torsion spring grille mounting - no tools required

FAN ASSEMBLY:

- Plug-in, permanently lubricated motor
- Polymeric blower wheel
- Galvanized steel motor bracket and motor plate
- Fits into your existing bath fan housing
- Two motor plate sizes included - to accommodate a variety of economy fan models

ACCESSORIES:

- Wrench and hardware included - no additional tools required
- Polymeric scroll band included - enhances performance of existing bath fan housings

SPECIFICATIONS

VOLTS	AMPS	CFM	SONES
120	1.2	60	3.0



HVI-2100 CERTIFIED RATINGS comply with new testing technologies and procedures prescribed by the Home Ventilating Institute, for off-the-shelf products, as they are available to consumers. Product performance is rated at 0.1 in. static pressure, based on tests conducted in AMCA's state-of-the-art test laboratory. Sones are a measure of humanly-perceived loudness, based on laboratory measurements.

For use only with these bath fan models:



NuTone 693, 695, 696N

The kit will work if your housing measures either 7½" x 7¼" or 8" x 7¼".



Broan 670, 671, 688, 689

The kit will work if your housing measures 7½" x 7¼".



Nautilus N671, N688

The kit will work if your housing measures 7½" x 7¼".

INSTALLATION

Complete installation instructions are included with each kit.

Bath Fan Upgrade Kit

MODEL 690NT

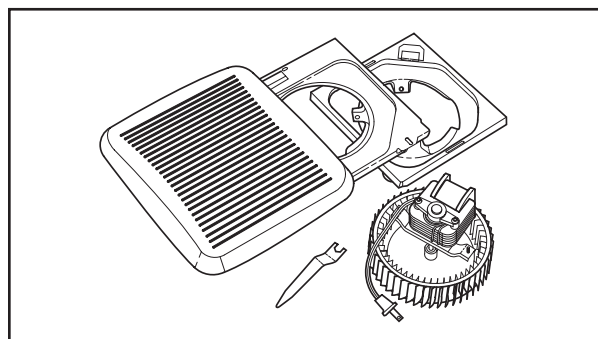

ARCHITECT'S SPECIFICATION

- Bath Fan Upgrade Kit shall be NuTone Model 690NT.
- Bath Fan Upgrade Kit shall include two galvanized steel motor plates designed to accommodate a variety of economy fan models.
- Motor shall be removable and permanently lubricated.
- Air delivery shall be no less than 60 cfm and sound level no greater than 3.0 Sones. All air and sound ratings shall be certified by HVI. Unit shall be U.L. Listed.

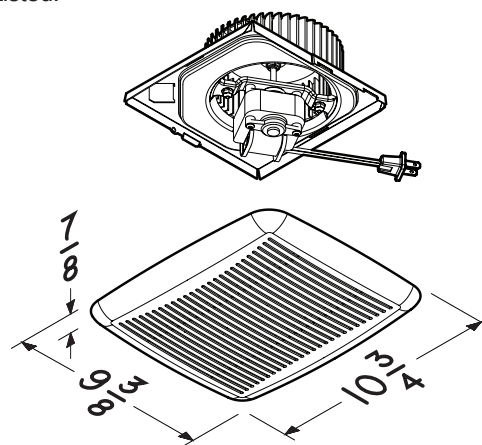

NuTone, Inc., 4820 Red Bank Road, Cincinnati, OH 45227 (1-800-543-8687)

REFERENCE	QTY.	REMARKS	Project
			Location
			Architect
			Engineer
			Contractor
			Submitted by Date