

# WIREMOLD



## Rectangular Floor Box Covers INSTALLATION INSTRUCTIONS

Installation Instruction No.: 1 003 807R3 – Updated December 2006

Walker® electrical systems conform to and should be properly grounded in compliance with requirements of the current National Electrical Code or codes administered by local authorities.

All electrical products may present a possible shock or fire hazard if improperly installed or used. Walker electrical products may bear the mark as UL Listed and/or Classified and should be installed in conformance with current local and/or the National Electrical Code.

**IMPORTANT: Please read all instructions before beginning.**

### Products Covered:

**Polycarbonate Trim Flanges:** 817PCC, 827PCC, 837PCC (BLK or BRN)

**Brass Trim Flanges:** 817C, 827C, 837C (Carpet), 817T, 827T, 837T (Tile) and 817B, 827B, 837B (Combination)

**Aluminum Trim Flanges:** 818TCAL, 828TCAL, 838TCAL (Tile/Carpet) and 818TAL, 828TAL, 838TAL-880S3, 838TAL-880M3, 838TAL-880CS3, 838TAL-880CM3 (Tile)

**Polycarbonate Activation Plates:** 828PPR, 828PRGFI, 829PSTC, 829PCK, 829PFL, 829PFLRT (BLK or BRN)

**Brass Activation Plates:** 828COMTC, 828DLR, 828DPGFITC, 828GFITC, 828R, 828SPTC, 829STC & 829CK Screw Plug Series

**Aluminum Activation Plates:** 828COMTCAL, 828DLRAL, 828DPGFITCAL, 828GFITCAL, 828R-TCAL & 830CKTCAL Screw Plug Series

### BOX/PRESET LOCATION:

1. Determine location of box or preset by measuring (when layout is known) or by using an electronic preset finder (Cat. No. 480). Cut and remove carpeting or tile over box or preset. Carpet may be saved for later abandoning.
2. Using a hammer, chip out the concrete from the mud cap cover.
3. Strike the edge of the exposed mud cap with a blade type screwdriver to deflect the cap inward.
4. Insert the screwdriver along the edge of the preset and pry up removing the cap.
5. Remove any debris that may have fallen into the enclosure.
6. Grout around the opening if concrete does not break away cleanly.

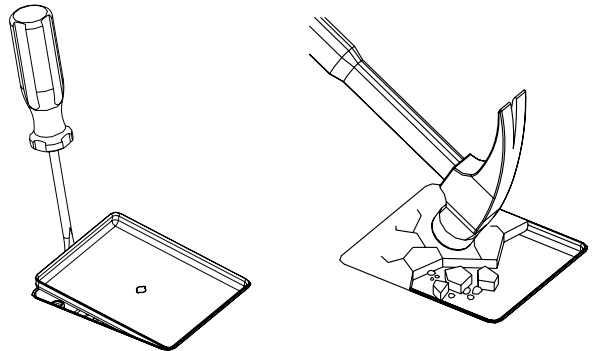

### PRO SERIES PRESET PREPARATION:

1. Remove knockout in bottom of preset by inserting a screwdriver blade into opening as shown.
2. Insert a wire hook into the arched opening to prevent the knockout from falling into the duct.
3. Push screwdriver toward center of the preset, breaking the tabs to release the knockout.
4. De-burr the edges after knockout removal and clean all debris from the raceway.
5. Tighten the bonding screw in the base of the preset



### PRO SERIES PRESET TRIM FLANGE INSTALLATION:

1. Secure link straps to posts in the preset.
2. Attach the trim flange to the link straps with four #10 flat head screws. Two lengths of screws are provided to accommodate variations in floor thickness.
3. If installing on a tile or wood floor, apply a bead of sealant around the underside of the flange to prevent water leakage into the preset.
4. For a flush appearance with wood floors, cut an opening 1/8" [3.2mm] deep conforming to the trim ring perimeter and recess into the floor.

**NOTE: Only "AL", "B", or "PCC" Series Trim Flanges may be installed on Pro Series Presets and Aftersets.**

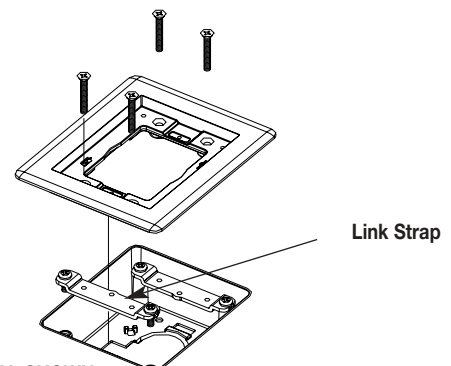

CAT. NO. 817TCAL SHOWN

**OMNIBOX TRIM FLANGE INSTALLATION:**

1. Install adjusting screws in box by sliding the beveled head under the retaining slot.
2. Secure the trim flange by inserting a narrow blade screwdriver through the adjusting screw holes and turning counterclockwise (Make small adjustments to avoid binding the screws).
3. If installing on a tile or wood floor, apply a bead of silicone around the underside of the flange to prevent water from leaking into the outlet box.

CAT. NO. 827PCC SHOWN

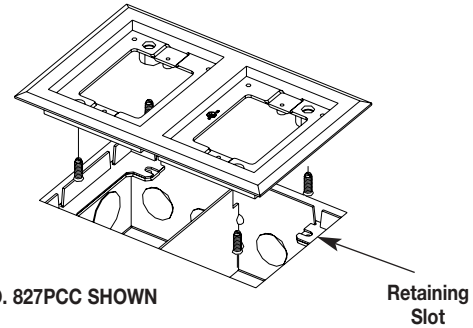

**NOTE:** Refer to current version of Instruction Sheet 1 005 001 for installing adjustable partitions required for the 838TAL Series Covers.

**NOTE:** All Trim Flanges are supplied with adjusting screws for a maximum upward adjustment of 1/2" [12.7mm]. Consult factory for upward adjustment greater than 1/2" [12.7mm].

**PLASTIC OR ALUMINUM DUPLEX RECEPTACLE COVER:**

1. Connect wires to receptacle and attach to trim flange.
2. Place gasket support plate over receptacle and attach with #6 truss head screw.
3. Place gasket over the support plate.
4. Attach cover with four (4) flat head screws.

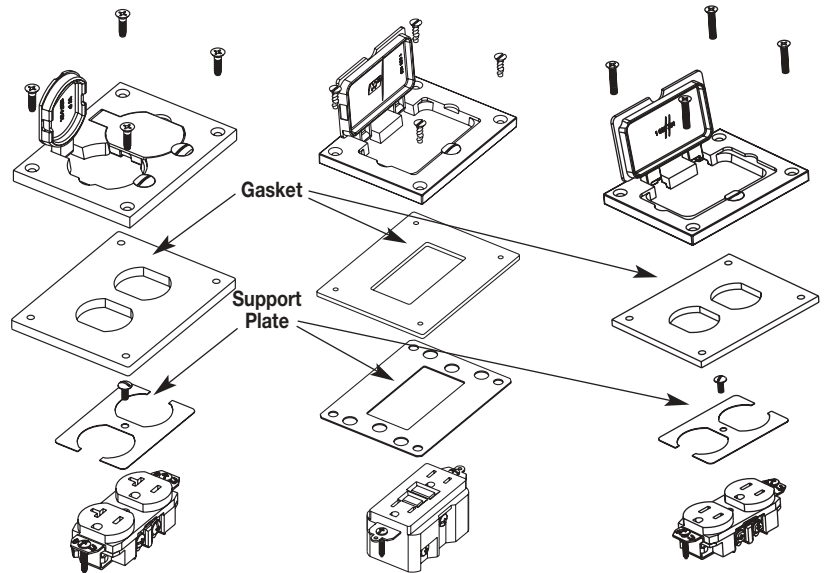

CAT. NO. 828PR SHOWN

CAT. NO. 828PRGFI SHOWN

CAT. NO. 828DPGFITCAL SHOWN

**PLASTIC & ALUMINUM GFCI RECEPTACLE COVER:**

1. Connect wires to receptacle and attach to trim flange.
2. Place gasket support plate over receptacle.
3. Place gasket over the support plate.
4. Attach cover with four (4) flat head screws.

**NOTE:** Plastic covers may be used with aluminum trim flanges. Attach plastic covers using #8-32 machine screws.

**BRASS DUPLEX RECEPTACLE COVER (828R & 828DPGFITC):**

1. Connect wires to receptacle and attach to trim flange.
2. Place gasket support plate over receptacle. Attach with #6 truss head screw.
3. Place gasket over support plate.
4. Attach cover with four (4) flat head screws.

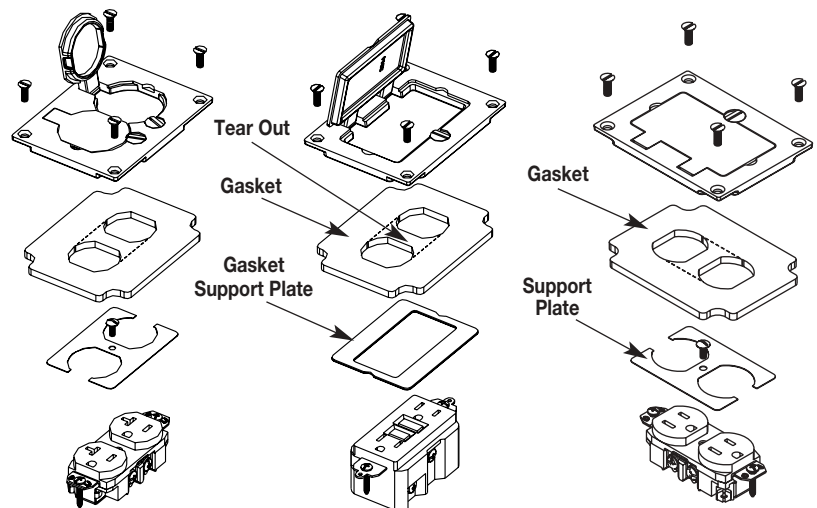

CAT. NO. 828R SHOWN

CAT. NO. 828GFITC SHOWN

CAT. NO. 828DPGFITC SHOWN

**BRASS GFCI RECEPTACLE COVER (828GFITC):**

1. Connect wires to receptacle and attach to trim flange.
2. Tear out perforated area of gasket.
3. Install gasket support plate over receptacle (B Series Flange only).
4. Place gasket over support plate.
5. Attach cover with four (4) flat head screws.

**SCREW COVER FOR POWER  
(ALUMINUM):**

1. Connect wire to receptacle and attach to trim flange.
2. Place gasket support plate over receptacle.
3. Place gasket over support plate.
4. Attach cover with four (4) flat head screws.



CAT. NO. 830CKTCLAL  
SHOWN

**BRASS AND ALUMINUM  
COVER FOR DATA OR TURN  
LOCK RECEPTACLE:**

1. Connect wire to receptacle and attach to trim flange.
2. Place gasket support plate over receptacle.
3. Place gasket over support plate.
4. Attach cover with four (4) flat head screws.

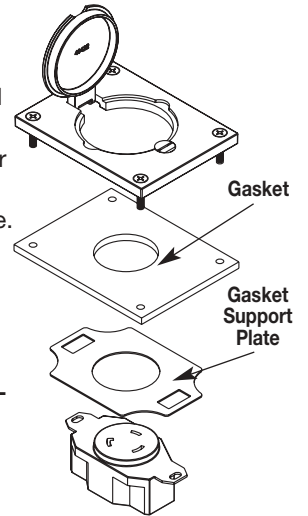

CAT. NO. 828DLRAL  
SHOWN

**DUPLEX RECEPTACLE SCREW PLUG COVER:**

1. Connect wires to receptacle and attach to trim flange.
2. Place gasket over receptacle.
3. Attach cover with four (4) flat head screws.
4. Install screw plugs when not in use.

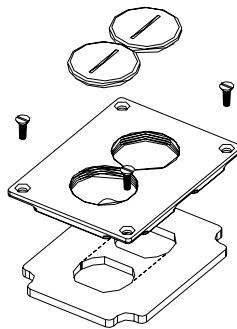

CAT. NO. 828SPTC SHOWN

**ADJUSTABLE SLIDE COVER:**

1. Extend cables through gasket. Invert slide and re-insert into cover plate.
2. Attach cover and gasket with four (4) flat head screws.
3. Adjust slide to accommodate the size of cable.

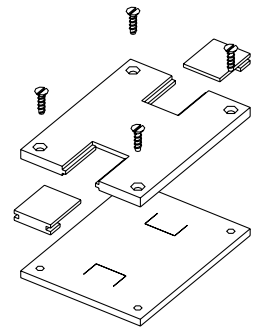

CAT. NO. 829PSTC SHOWN

**NOTE:** 829PSTC is for cable egress only, not for holding data jack.

**COMMUNICATIONS SCREW PLUG COVER:**

1. Extend cables through the foam gasket and cover.
2. Attach cover with four (4) flat head screws.
3. Install screw plugs when not in use.

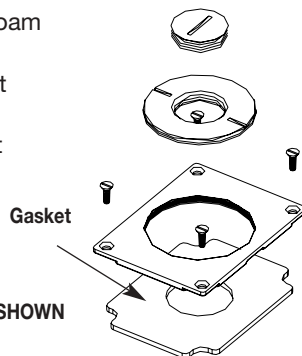

CAT. NO. 829CK-1 SHOWN  
BRASS

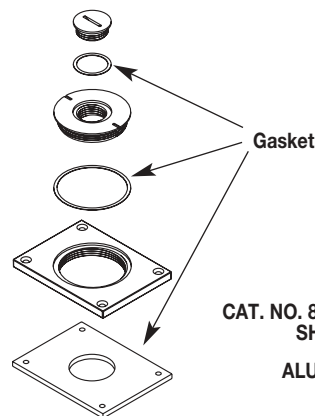

CAT. NO. 830CKTCL3-4  
SHOWN  
ALUMINUM

### BREAKOUT TAB COVER:

1. Cut a slit in gasket and extend cables through the opening.
2. Determine required openings in plate and remove knockouts from each half.
3. Fit plate halves around cables and attach with four (4) flat head screws.

CAT. NO. 829PCK SHOWN



### COMMUNICATION COVER:

1. Attach bezel into trim flange and run communication cables through the opening. Bezels must be in place prior to pulling cables to ensure no damage.
2. Wire and insert communication devices into the bezel.  
**CAUTION: Communication devices or blank inserts must be installed in bezel to provide scrub water seal.**
3. Place gasket and cover over the devices making sure the hinge pin side overlaps the label side of the communications modules.
4. Install four (4) flat head screws.

CAT. NO. 829PFL SHOWN



### BRASS & ALUMINUM COVERS FOR KEYSTONE JACKS:

1. Attach recessed adapter to flange.
2. Pull wire through recessed adapter and attach to keystone jacks. (Keystone jacks not supplied.)
3. Attach keystone jacks to bezels and install into recessed adapter.
4. Place gasket over recessed adapter.
5. Attach cover with four (4) flat head screws.

CAT. NO. 828COMTCAL SHOWN



# WIREMOLD



**Wiremold / Legrand**

U.S. and International:

60 Woodlawn Street • West Hartford, CT 06110

1-800-621-0049 • FAX 860-232-2062 • Outside U.S.: 860-233-6251

Canada:

570 Applewood Crescent • Vaughan, Ontario L4K 4B4

1-800-723-5175 • FAX 905-738-9721



# WIREMOLD



## Rectangular Floor Box Covers INSTALLATION INSTRUCTIONS

Installation Instruction No.: 1 003 807R3 – Updated December 2006

Walker® electrical systems conform to and should be properly grounded in compliance with requirements of the current National Electrical Code or codes administered by local authorities.

All electrical products may present a possible shock or fire hazard if improperly installed or used. Walker electrical products may bear the mark as UL Listed and/or Classified and should be installed in conformance with current local and/or the National Electrical Code.

**IMPORTANT: Please read all instructions before beginning.**

### Products Covered:

**Polycarbonate Trim Flanges:** 817PCC, 827PCC, 837PCC (BLK or BRN)

**Brass Trim Flanges:** 817C, 827C, 837C (Carpet), 817T, 827T, 837T (Tile) and 817B, 827B, 837B (Combination)

**Aluminum Trim Flanges:** 818TCAL, 828TCAL, 838TCAL (Tile/Carpet) and 818TAL, 828TAL, 838TAL-880S3, 838TAL-880M3, 838TAL-880CS3, 838TAL-880CM3 (Tile)

**Polycarbonate Activation Plates:** 828PPR, 828PRGFI, 829PSTC, 829PCK, 829PFL, 829PFLRT (BLK or BRN)

**Brass Activation Plates:** 828COMTC, 828DLR, 828DPGFITC, 828GFITC, 828R, 828SPTC, 829STC & 829CK Screw Plug Series

**Aluminum Activation Plates:** 828COMTCAL, 828DLRAL, 828DPGFITCAL, 828GFITCAL, 828R-TCAL & 830CKTCAL Screw Plug Series

### BOX/PRESET LOCATION:

1. Determine location of box or preset by measuring (when layout is known) or by using an electronic preset finder (Cat. No. 480). Cut and remove carpeting or tile over box or preset. Carpet may be saved for later abandoning.
2. Using a hammer, chip out the concrete from the mud cap cover.
3. Strike the edge of the exposed mud cap with a blade type screwdriver to deflect the cap inward.
4. Insert the screwdriver along the edge of the preset and pry up removing the cap.
5. Remove any debris that may have fallen into the enclosure.
6. Grout around the opening if concrete does not break away cleanly.



### PRO SERIES PRESET PREPARATION:

1. Remove knockout in bottom of preset by inserting a screwdriver blade into opening as shown.
2. Insert a wire hook into the arched opening to prevent the knockout from falling into the duct.
3. Push screwdriver toward center of the preset, breaking the tabs to release the knockout.
4. De-burr the edges after knockout removal and clean all debris from the raceway.
5. Tighten the bonding screw in the base of the preset



### PRO SERIES PRESET TRIM FLANGE INSTALLATION:

1. Secure link straps to posts in the preset.
2. Attach the trim flange to the link straps with four #10 flat head screws. Two lengths of screws are provided to accommodate variations in floor thickness.
3. If installing on a tile or wood floor, apply a bead of sealant around the underside of the flange to prevent water leakage into the preset.
4. For a flush appearance with wood floors, cut an opening 1/8" [3.2mm] deep conforming to the trim ring perimeter and recess into the floor.



**NOTE: Only "AL", "B", or "PCC" Series Trim Flanges may be installed on Pro Series Presets and Aftersets.**

CAT. NO. 817TCAL SHOWN



**OMNIBOX TRIM FLANGE INSTALLATION:**

1. Install adjusting screws in box by sliding the beveled head under the retaining slot.
2. Secure the trim flange by inserting a narrow blade screwdriver through the adjusting screw holes and turning counterclockwise (Make small adjustments to avoid binding the screws).
3. If installing on a tile or wood floor, apply a bead of silicone around the underside of the flange to prevent water from leaking into the outlet box.

CAT. NO. 827PCC SHOWN

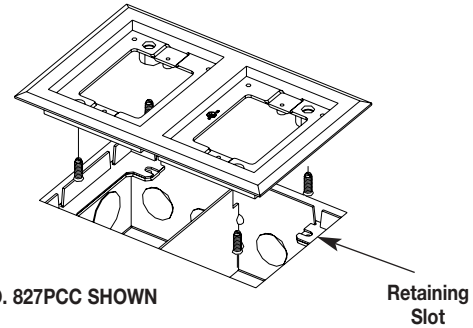

**NOTE:** Refer to current version of Instruction Sheet 1 005 001 for installing adjustable partitions required for the 838TAL Series Covers.

**NOTE:** All Trim Flanges are supplied with adjusting screws for a maximum upward adjustment of 1/2" [12.7mm]. Consult factory for upward adjustment greater than 1/2" [12.7mm].

**PLASTIC OR ALUMINUM DUPLEX RECEPTACLE COVER:**

1. Connect wires to receptacle and attach to trim flange.
2. Place gasket support plate over receptacle and attach with #6 truss head screw.
3. Place gasket over the support plate.
4. Attach cover with four (4) flat head screws.

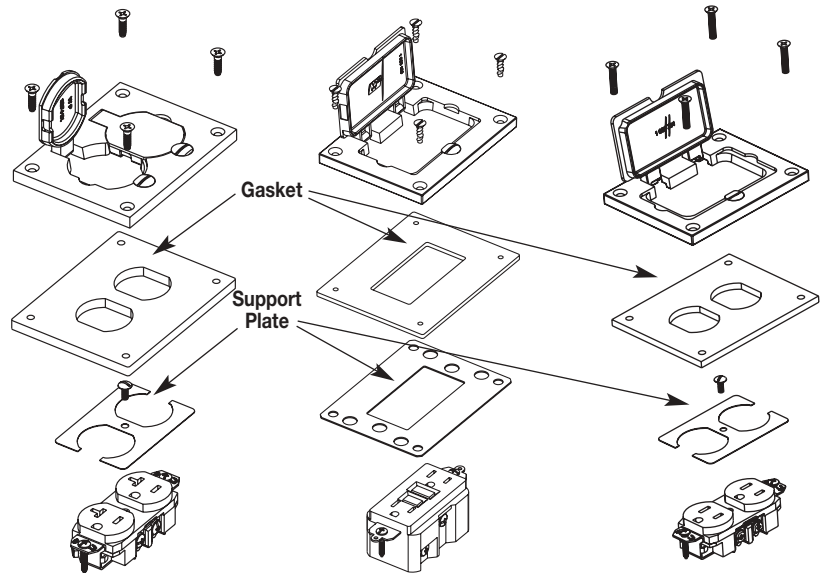

CAT. NO. 828PR SHOWN

CAT. NO. 828PRGFI SHOWN

CAT. NO. 828DPGFITCAL SHOWN

**PLASTIC & ALUMINUM GFCI RECEPTACLE COVER:**

1. Connect wires to receptacle and attach to trim flange.
2. Place gasket support plate over receptacle.
3. Place gasket over the support plate.
4. Attach cover with four (4) flat head screws.

**NOTE:** Plastic covers may be used with aluminum trim flanges. Attach plastic covers using #8-32 machine screws.

**BRASS DUPLEX RECEPTACLE COVER (828R & 828DPGFITC):**

1. Connect wires to receptacle and attach to trim flange.
2. Place gasket support plate over receptacle. Attach with #6 truss head screw.
3. Place gasket over support plate.
4. Attach cover with four (4) flat head screws.

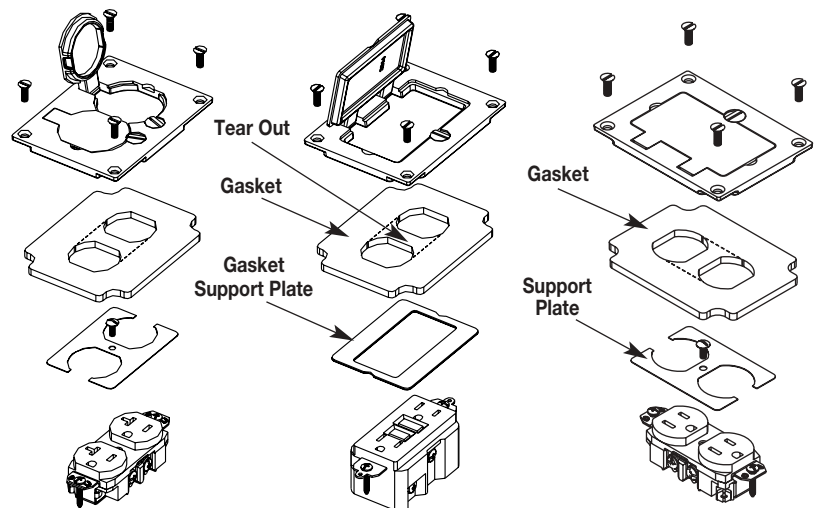

CAT. NO. 828R SHOWN

CAT. NO. 828GFITC SHOWN

CAT. NO. 828DPGFITC SHOWN

**BRASS GFCI RECEPTACLE COVER (828GFITC):**

1. Connect wires to receptacle and attach to trim flange.
2. Tear out perforated area of gasket.
3. Install gasket support plate over receptacle (B Series Flange only).
4. Place gasket over support plate.
5. Attach cover with four (4) flat head screws.

**SCREW COVER FOR POWER  
(ALUMINUM):**

1. Connect wire to receptacle and attach to trim flange.
2. Place gasket support plate over receptacle.
3. Place gasket over support plate.
4. Attach cover with four (4) flat head screws.

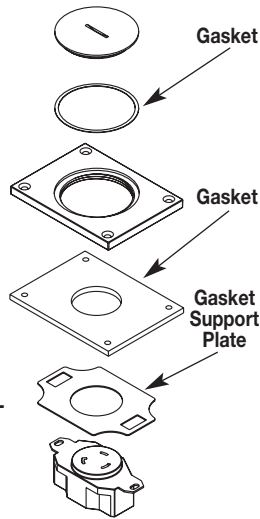

CAT. NO. 830CKTCLAL  
SHOWN

**BRASS AND ALUMINUM  
COVER FOR DATA OR TURN  
LOCK RECEPTACLE:**

1. Connect wire to receptacle and attach to trim flange.
2. Place gasket support plate over receptacle.
3. Place gasket over support plate.
4. Attach cover with four (4) flat head screws.

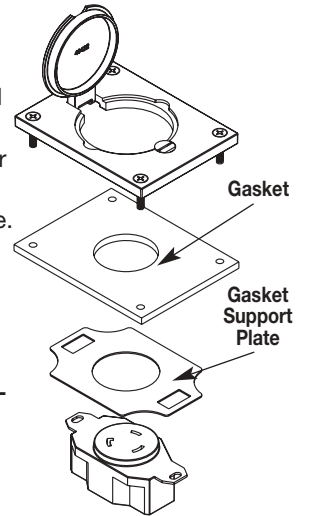

CAT. NO. 828DLRAL  
SHOWN

**DUPLEX RECEPTACLE SCREW PLUG COVER:**

1. Connect wires to receptacle and attach to trim flange.
2. Place gasket over receptacle.
3. Attach cover with four (4) flat head screws.
4. Install screw plugs when not in use.

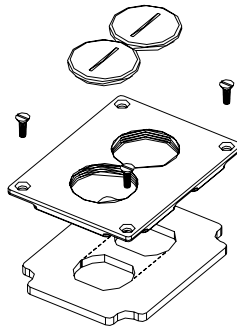

CAT. NO. 828SPTC SHOWN

**ADJUSTABLE SLIDE COVER:**

1. Extend cables through gasket. Invert slide and re-insert into cover plate.
2. Attach cover and gasket with four (4) flat head screws.
3. Adjust slide to accommodate the size of cable.

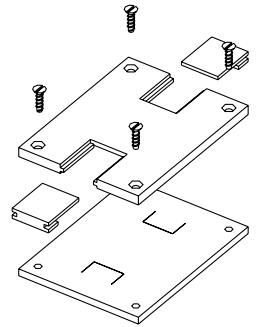

CAT. NO. 829PSTC SHOWN

**NOTE:** 829PSTC is for cable egress only, not for holding data jack.

**COMMUNICATIONS SCREW PLUG COVER:**

1. Extend cables through the foam gasket and cover.
2. Attach cover with four (4) flat head screws.
3. Install screw plugs when not in use.

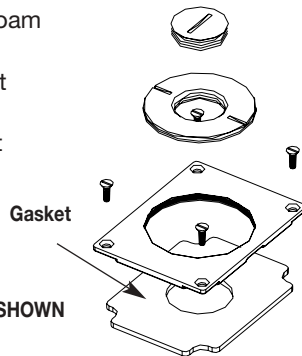

CAT. NO. 829CK-1 SHOWN  
BRASS



CAT. NO. 830CKTCL3-4  
SHOWN  
ALUMINUM

### BREAKOUT TAB COVER:

1. Cut a slit in gasket and extend cables through the opening.
2. Determine required openings in plate and remove knockouts from each half.
3. Fit plate halves around cables and attach with four (4) flat head screws.

CAT. NO. 829PCK SHOWN



### COMMUNICATION COVER:

1. Attach bezel into trim flange and run communication cables through the opening. Bezels must be in place prior to pulling cables to ensure no damage.
2. Wire and insert communication devices into the bezel.  
**CAUTION: Communication devices or blank inserts must be installed in bezel to provide scrub water seal.**
3. Place gasket and cover over the devices making sure the hinge pin side overlaps the label side of the communications modules.
4. Install four (4) flat head screws.

CAT. NO. 829PFL SHOWN



### BRASS & ALUMINUM COVERS FOR KEYSTONE JACKS:

1. Attach recessed adapter to flange.
2. Pull wire through recessed adapter and attach to keystone jacks. (Keystone jacks not supplied.)
3. Attach keystone jacks to bezels and install into recessed adapter.
4. Place gasket over recessed adapter.
5. Attach cover with four (4) flat head screws.

CAT. NO. 828COMTCAL SHOWN



# WIREMOLD



**Wiremold / Legrand**

U.S. and International:

60 Woodlawn Street • West Hartford, CT 06110

1-800-621-0049 • FAX 860-232-2062 • Outside U.S.: 860-233-6251

Canada:

570 Applewood Crescent • Vaughan, Ontario L4K 4B4

1-800-723-5175 • FAX 905-738-9721

