

**First Alert**

cat. **AC10-500B**

## Wi-Fi Smoke + Carbon Monoxide Alarm

**10YR CO Sensor/10YR Alarm Life/  
10YR Battery backup**

10 year CO sensor and alarm life. Sealed, tamper proof batteries last 10 years.

### Wireless Interconnect

Bluetooth BLE communication between alarms and Wi-Fi to connect to your smart phone or tablet.

### Flood Mesh Network Communication

2-way communication format that sends, receives and re-sends the alarm signals providing a more reliable network.

### App

Receive notifications in case of an alarm, test and silence, check alarm battery life levels, alarm history, and CO levels.

### Talking Alarm

Voice and location technology tells you the type of danger and the location. Choose from 13 pre-programmed alarm locations. Plan safest path to exit.

### Multi-Color Indicator Ring

Multi-color light ring provides visual indication of various alarm states.

### 2-in-1 Protection

Detects smoke and carbon monoxide in one alarm. Provides best protection throughout the home.

### Photoelectric Smoke Sensor

Helps reduce false alarms caused by cooking smoke or shower steam.

### Hardwire Compatibility

Can be interconnected with all First Alert/BRK hardwired smoke, CO and Combo alarms.



# Onelink™

## 120V Hardwired with 10YR Sealed Lithium Battery Backup

### Description:

First Alert Onelink AC10-500B (model AC10-500) is a single station combination smoke and CO alarm specifically designed for residential and institutional applications including sleeping rooms of hospitals, hotels, motels, dormitories, and other multifamily dwellings as defined in standard NFPA 101. It has been fully tested and complies with, UL217, UL2034, CSFM, NFPA 72, NFPA 720, HUD, CSFM and NFPA 101 and other agencies that model their codes after the above agencies. It meets building codes where AC hardwired with battery backup smoke and CO alarms are required either separately or in combination along with wireless interconnect, voice with location and silence features and with model building codes published by the ICC.

First Alert Onelink AC10-500B is a state of the art wireless talking combination smoke and CO alarm designed to provide early warning of a fire or CO. It features a fully insect screened Photoelectric smoke sensing chamber and an electrochemical carbon monoxide sensor, an 85dB horn, a full function test switch and a silence feature. The multi-color light ring provides visual indication of various alarm states. This combination alarm interconnects via Bluetooth BLE communication. It also connects to your wireless router via Wi-Fi to provide access to your Apple smart device. You have a choice of 13 pre-programmed locations where a voice will announce the location and danger detected. When interconnected with other First Alert Onelink alarms it will also announce the danger and location detected of that alarm too. It operates on a Mesh Network; a two-way communication format that sends, receives and re-sends the alarm signals providing a more reliable network. Perfect for apartment, dormitory or hotel applications. Designed for wall or ceiling mounting. Includes mounting anchors and screws.



# cat. AC10-500B

## Line Drawing Specifications

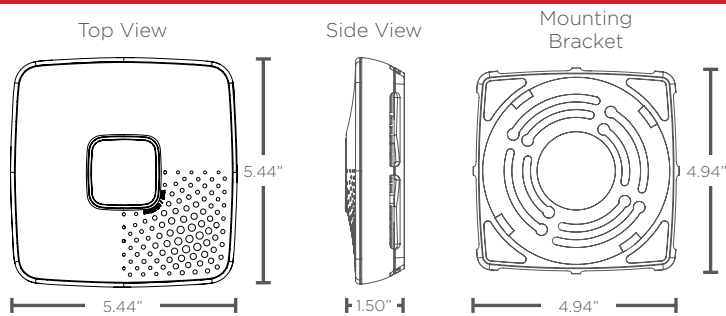

## Architectural And Engineering Specs

The alarm shall be a BRK/First Alert Model AC10-500 and shall provide at a minimum the following features and functions:

1. A photoelectric smoke sensing chamber and an electrochemical CO sensor.
2. The unit shall be capable of self restoring.
3. A fully screened smoke sensing chamber to resist entry of small insects thereby reducing the probability of unwanted alarms.
4. Powered by 120V AC, 60Hz and have a monitored sealed 10-year lithium powercell with a tamperproof design battery backup. The tamperproof design shall not allow the powercell to be removed.
5. Wireless Interconnect: Bluetooth BLE communication between alarms and Wi-Fi to connect to your Apple smart phone or tablet.
6. A Voice Warning of danger detected in addition to speaking one of 13 pre-programmed locations, e.g. "Warning, Evacuate, Smoke in Basement".
7. Flood Mesh Network Communication: 2-way communication format that sends, receives and re-sends the alarm signals providing a more reliable network.
8. Free App/Activity Log: App provides real time notification and history logging of all events by alarm so you can easily identify condition and troubleshoot incidents such as identifying initiating alarm or low battery condition.
9. A solid state piezo horn rated at 85dB at 10 ft.
10. A low power warning indicator shall cause the alarm to "chirp" when it reaches the end of its service life and needs to be replaced. Upon end of life, the unit shall meet UL requirements for disabling the alarm and the non re-installation of unit to mounting bracket.
11. Multi-Color Indicator Ring: provides visual indication of various alarm states. Green: Normal or completed operation; Blue: Voice prompts or Pairing; Red: Alarm/Warning; Amber: Malfunction/End of Life; White: Night light
12. A full function test button. The test button should check all alarm functions by stimulating the chamber to simulate a smoke or CO condition, causing the unit to alarm. The unit should also have a silence feature to silence unwanted nuisance alarms.
13. The unit shall be capable of operating between 40°F (4°C) and 100°F (38°C) and relative humidity between 10% and 95%.
14. The unit shall contain mounting hardware and shall be listed for wall or ceiling mounting.
15. The unit shall at a minimum meet the requirements of UL217, UL2034, CSFM, HUD, NFPA 72, NFPA 720, NFPA 101, ICC.

## Parts of this Alarm

Installation of this alarm must conform to all local electrical codes and Article 760 of the National Electrical Code (NFPA 70) and NFPA 72 and NFPA 720. Interconnected units must meet the following requirements: Total length of wire interconnecting units should be less than 1000 feet, be #18 gauge or larger and be rated at least 300V. It is recommended that all units be on the same fuse or circuit breaker. If local codes do not permit, be sure the neutral wire is common to both phases.

### Top of Alarm

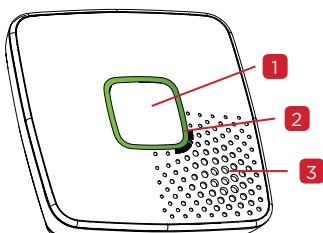

#### TOP OF ALARM

- 1 Test Silence Button
- 2 Color Indicator Ring
- 3 Speaker/Alarm Horn

#### INSTALLED/BOTTOM OF ALARM

- 1 Alarm
  - 2 Ceiling or Wall
  - 3 Quick Connect Plug
  - 4 Wire Nut
  - 5 Junction Box
  - 6 Neutral Wire (White)
  - 7 Interconnect Wire (Orange)
  - 8 Hot Wire (Black)
  - 9 Mounting Bracket
  - 10 Mounting Slots
- A From un-switched 120V AC 60 Hz source  
B To additional units; Maximum = 18 total (Maximum 12 Smoke Alarms)

### Installed/Bottom of Alarm

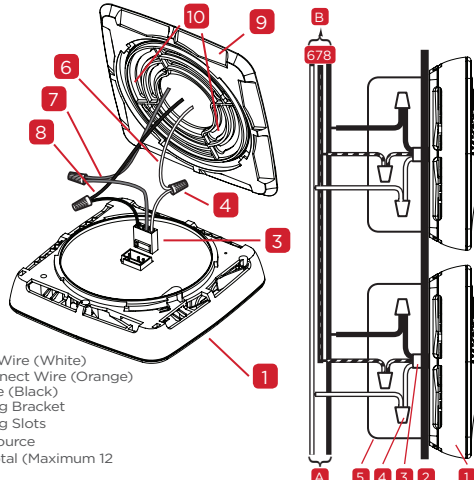

## Technical Specifications

Alarm Dimensions:	5.44"L x 5.44"W x 1.50"H
Alarm Weight:	11.4 oz
Operating Voltage:	120V AC 60Hz with 3V lithium battery backup
Power (Standby/Alarm):	0.012A/0.065A
Temperature Range:	40°F (4°C) to 100°F (38°C)
Humidity Range:	10% to 95% relative humidity (RH)
Audio Alarm:	85dB at 10 feet
Voice Output:	Choice of 13 pre-programmed locations
BLE Wireless Frequency:	2.4 GHz. FCC approved. Complies with Part 15 of the FCC Rules.
Wi-Fi:	IEEE 802.11 b/g/n Radio/WLAN
Test/Silence:	Electronically simulates smoke and/or CO conditions causing the unit to alarm. Press and hold test/silence button.
Alarm Reset:	Automatic when smoke and/or CO clears
Smoke Sensor:	Photoelectric
CO Sensor:	Electrochemical
Interconnections:	Up to 18 units, BLE or hardwired (needs AC10-500B Bridge Unit), with smoke, carbon monoxide, heat alarms and relays. Maximum 12 smoke alarms.
Listing:	UL217 and UL2034 Standards

## Shipping Specifications

### Individual Carton

Dimensions	6.31"W x 3.25"D x 6.50"H
Weight	1.06 lbs.
Cube	0.08 ft <sup>3</sup>
UPC	0 29054 01568 6

### Master Carton

Dimensions	10.63"L x 6.63"W x 7.13"H
Master Pack	3
Weight	3.6 lbs.
Cube:	0.28 ft <sup>3</sup>
12 of 5:	300 29054 01568 7

### Pallet Information

Cases per Layer	26
Number of Layers:	7
Cases per Pallet:	182
Units per Pallet:	546
Cube:	58.9 ft <sup>3</sup>
Weight:	713 lbs.

©2015 BRK Brands, Inc. All rights reserved. Distributed by BRK Brands, Inc., Aurora, Illinois 60504. First Alert® is a registered trademark of The First Alert Trust. BRK Brands, Inc. is a subsidiary of Jarden Corporation (NYSE: JAH). Wi-Fi® is a registered trademark of Wi-Fi Alliance. App Store is a service mark of Apple Inc. Apple, iPhone, iPad, iPad Air, and iPod touch are trademarks of Apple Inc., registered in the U.S. and other countries. HomeKit is a trademark of Apple Inc. App Store is a service mark of Apple Inc. Controlling HomeKit-enabled accessories away from home requires an Apple TV (3rd generation or later) with Apple TV software 7.0 or later and an iPhone, iPad, or iPod touch with iOS 9 or later. HomeKit requires an iPhone, iPad, or iPod touch with iOS 9 or later. The Bluetooth® word mark and logos are registered trademarks owned by Bluetooth SIG, Inc. and any use of such marks by BRK Brands, Inc., is under license. Other trademarks and trade names are those of their respective owners. CM3256



**First Alert**

cat. **AC10-500B**

## Wi-Fi Smoke + Carbon Monoxide Alarm

**10YR CO Sensor/10YR Alarm Life/  
10YR Battery backup**

10 year CO sensor and alarm life. Sealed, tamper proof batteries last 10 years.

### Wireless Interconnect

Bluetooth BLE communication between alarms and Wi-Fi to connect to your smart phone or tablet.

### Flood Mesh Network Communication

2-way communication format that sends, receives and re-sends the alarm signals providing a more reliable network.

### App

Receive notifications in case of an alarm, test and silence, check alarm battery life levels, alarm history, and CO levels.

### Talking Alarm

Voice and location technology tells you the type of danger and the location. Choose from 13 pre-programmed alarm locations. Plan safest path to exit.

### Multi-Color Indicator Ring

Multi-color light ring provides visual indication of various alarm states.

### 2-in-1 Protection

Detects smoke and carbon monoxide in one alarm. Provides best protection throughout the home.

### Photoelectric Smoke Sensor

Helps reduce false alarms caused by cooking smoke or shower steam.

### Hardwire Compatibility

Can be interconnected with all First Alert/BRK hardwired smoke, CO and Combo alarms.



# Onelink™

## 120V Hardwired with 10YR Sealed Lithium Battery Backup

### Description:

First Alert Onelink AC10-500B (model AC10-500) is a single station combination smoke and CO alarm specifically designed for residential and institutional applications including sleeping rooms of hospitals, hotels, motels, dormitories, and other multifamily dwellings as defined in standard NFPA 101. It has been fully tested and complies with, UL217, UL2034, CSFM, NFPA 72, NFPA 720, HUD, CSFM and NFPA 101 and other agencies that model their codes after the above agencies. It meets building codes where AC hardwired with battery backup smoke and CO alarms are required either separately or in combination along with wireless interconnect, voice with location and silence features and with model building codes published by the ICC.

First Alert Onelink AC10-500B is a state of the art wireless talking combination smoke and CO alarm designed to provide early warning of a fire or CO. It features a fully insect screened Photoelectric smoke sensing chamber and an electrochemical carbon monoxide sensor, an 85dB horn, a full function test switch and a silence feature. The multi-color light ring provides visual indication of various alarm states. This combination alarm interconnects via Bluetooth BLE communication. It also connects to your wireless router via Wi-Fi to provide access to your Apple smart device. You have a choice of 13 pre-programmed locations where a voice will announce the location and danger detected. When interconnected with other First Alert Onelink alarms it will also announce the danger and location detected of that alarm too. It operates on a Mesh Network; a two-way communication format that sends, receives and re-sends the alarm signals providing a more reliable network. Perfect for apartment, dormitory or hotel applications. Designed for wall or ceiling mounting. Includes mounting anchors and screws.



# cat. AC10-500B

## Line Drawing Specifications

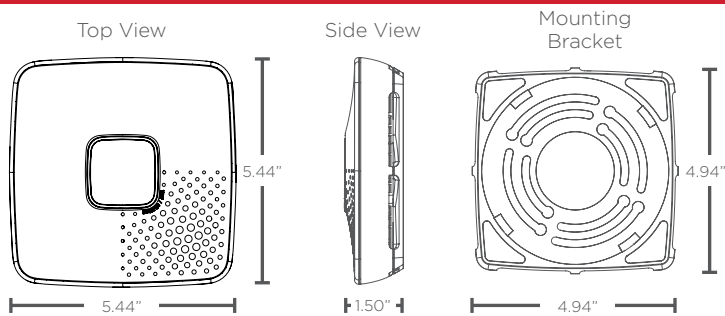

## Architectural And Engineering Specs

The alarm shall be a BRK/First Alert Model AC10-500 and shall provide at a minimum the following features and functions:

1. A photoelectric smoke sensing chamber and an electrochemical CO sensor.
2. The unit shall be capable of self restoring.
3. A fully screened smoke sensing chamber to resist entry of small insects thereby reducing the probability of unwanted alarms.
4. Powered by 120V AC, 60Hz and have a monitored sealed 10-year lithium powercell with a tamperproof design battery backup. The tamperproof design shall not allow the powercell to be removed.
5. Wireless Interconnect: Bluetooth BLE communication between alarms and Wi-Fi to connect to your Apple smart phone or tablet.
6. A Voice Warning of danger detected in addition to speaking one of 13 pre-programmed locations, e.g. "Warning, Evacuate, Smoke in Basement".
7. Flood Mesh Network Communication: 2-way communication format that sends, receives and re-sends the alarm signals providing a more reliable network.
8. Free App/Activity Log: App provides real time notification and history logging of all events by alarm so you can easily identify condition and troubleshoot incidents such as identifying initiating alarm or low battery condition.
9. A solid state piezo horn rated at 85dB at 10 ft.
10. A low power warning indicator shall cause the alarm to "chirp" when it reaches the end of its service life and needs to be replaced. Upon end of life, the unit shall meet UL requirements for disabling the alarm and the non re-installation of unit to mounting bracket.
11. Multi-Color Indicator Ring: provides visual indication of various alarm states. Green: Normal or completed operation; Blue: Voice prompts or Pairing; Red: Alarm/Warning; Amber: Malfunction/End of Life; White: Night light
12. A full function test button. The test button should check all alarm functions by stimulating the chamber to simulate a smoke or CO condition, causing the unit to alarm. The unit should also have a silence feature to silence unwanted nuisance alarms.
13. The unit shall be capable of operating between 40°F (4°C) and 100°F (38°C) and relative humidity between 10% and 95%.
14. The unit shall contain mounting hardware and shall be listed for wall or ceiling mounting.
15. The unit shall at a minimum meet the requirements of UL217, UL2034, CSFM, HUD, NFPA 72, NFPA 720, NFPA 101, ICC.

## Parts of this Alarm

Installation of this alarm must conform to all local electrical codes and Article 760 of the National Electrical Code (NFPA 70) and NFPA 72 and NFPA 720. Interconnected units must meet the following requirements: Total length of wire interconnecting units should be less than 1000 feet, be #18 gauge or larger and be rated at least 300V. It is recommended that all units be on the same fuse or circuit breaker. If local codes do not permit, be sure the neutral wire is common to both phases.

### Top of Alarm

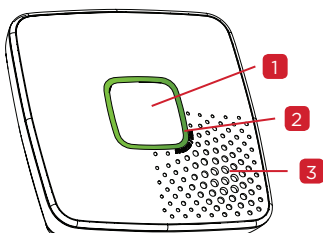

#### TOP OF ALARM

- 1 Test Silence Button
- 2 Color Indicator Ring
- 3 Speaker/Alarm Horn

#### INSTALLED/BOTTOM OF ALARM

- 1 Alarm
  - 2 Ceiling or Wall
  - 3 Quick Connect Plug
  - 4 Wire Nut
  - 5 Junction Box
  - 6 Neutral Wire (White)
  - 7 Interconnect Wire (Orange)
  - 8 Hot Wire (Black)
  - 9 Mounting Bracket
  - 10 Mounting Slots
- A From un-switched 120V AC 60 Hz source  
B To additional units; Maximum = 18 total (Maximum 12 Smoke Alarms)

### Installed/Bottom of Alarm

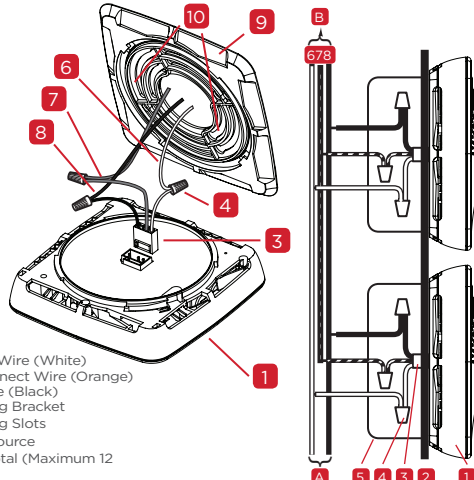

## Technical Specifications

Alarm Dimensions:	5.44"L x 5.44"W x 1.50"H
Alarm Weight:	11.4 oz
Operating Voltage:	120V AC 60Hz with 3V lithium battery backup
Power (Standby/Alarm):	0.012A/0.065A
Temperature Range:	40°F (4°C) to 100°F (38°C)
Humidity Range:	10% to 95% relative humidity (RH)
Audio Alarm:	85dB at 10 feet
Voice Output:	Choice of 13 pre-programmed locations
BLE Wireless Frequency:	2.4 GHz. FCC approved. Complies with Part 15 of the FCC Rules.
Wi-Fi:	IEEE 802.11 b/g/n Radio/WLAN
Test/Silence:	Electronically simulates smoke and/or CO conditions causing the unit to alarm. Press and hold test/silence button.
Alarm Reset:	Automatic when smoke and/or CO clears
Smoke Sensor:	Photoelectric
CO Sensor:	Electrochemical
Interconnections:	Up to 18 units, BLE or hardwired (needs AC10-500B Bridge Unit), with smoke, carbon monoxide, heat alarms and relays. Maximum 12 smoke alarms.
Listing:	UL217 and UL2034 Standards

## Shipping Specifications

### Individual Carton

Dimensions	6.31"W x 3.25"D x 6.50"H
Weight	1.06 lbs.
Cube	0.08 ft <sup>3</sup>
UPC	0 29054 01568 6

### Master Carton

Dimensions	10.63"L x 6.63"W x 7.13"H
Master Pack	3
Weight	3.6 lbs.
Cube:	0.28 ft <sup>3</sup>
12 of 5:	300 29054 01568 7

### Pallet Information

Cases per Layer	26
Number of Layers:	7
Cases per Pallet:	182
Units per Pallet:	546
Cube:	58.9 ft <sup>3</sup>
Weight:	713 lbs.

©2015 BRK Brands, Inc. All rights reserved. Distributed by BRK Brands, Inc., Aurora, Illinois 60504. First Alert® is a registered trademark of The First Alert Trust. BRK Brands, Inc. is a subsidiary of Jarden Corporation (NYSE: JAH). Wi-Fi® is a registered trademark of Wi-Fi Alliance. App Store is a service mark of Apple Inc. Apple, iPhone, iPad, iPad Air, and iPod touch are trademarks of Apple Inc., registered in the U.S. and other countries. HomeKit is a trademark of Apple Inc. App Store is a service mark of Apple Inc. Controlling HomeKit-enabled accessories away from home requires an Apple TV (3rd generation or later) with Apple TV software 7.0 or later and an iPhone, iPad, or iPod touch with iOS 9 or later. HomeKit requires an iPhone, iPad, or iPod touch with iOS 9 or later. The Bluetooth® word mark and logos are registered trademarks owned by Bluetooth SIG, Inc. and any use of such marks by BRK Brands, Inc., is under license. Other trademarks and trade names are those of their respective owners. CM3256

