

Secondary arresters and protective gaps



General information

The necessity of providing surge arrester protection on low-voltage circuits is fundamentally the same as for primary system protection. While secondary lines usually are shorter than primary lines, they still are subject to surges which can cause stresses beyond the insulation withstand strength of connected equipment.

Secondary arresters

Type L

Eaton protects street-lighting controls, low-voltage relays, railroad-signal circuits and circuits used for fire alarms, remote metering and airport lighting with its Cooper Power™ series Type L secondary arresters. They are applicable for voltages up to 175 Vac, or 125 Vdc and are designed for indoor mounting. For general circuit applications refer to Table 1.

Type S4

Eaton provides protection of low-voltage equipment, secondary distribution circuits, control circuits and signal circuits up to 650 Vac with its Cooper Power series Type S4 secondary arresters. These arresters are designed for both indoor and outdoor use and a typical application would be to protect long and exposed secondary systems in oil fields or rural areas.

Protective gaps

Eaton isolates electrical equipment during normal service conditions and provides a path to ground for surge current during arrester operations with its Cooper Power series protective gaps. Protective gaps used for interconnection of arrester ground, secondary neutral, and transformer tank provide additional protection to distribution transformers and improve continuity of service to customers. Protective gaps provide effective and inexpensive surge protection for the primary neutral of a system (grounded only at the substation) if the potential of the primary neutral is less than 350 volts (rms) above ground. Transformer tanks can be isolated from ground under normal conditions by connecting the transformer to ground through a protective gap.

EATON

Powering Business Worldwide

Features and detailed description

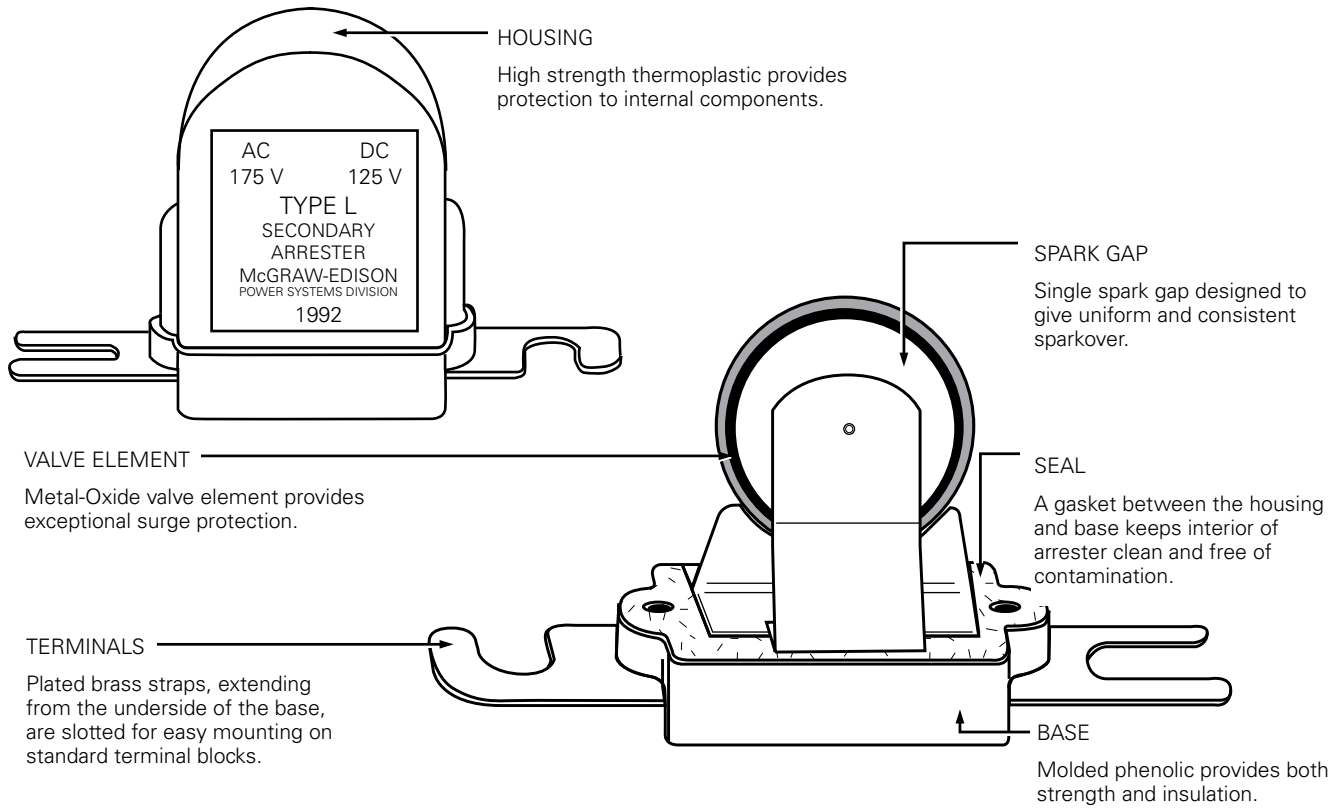

Figure 1. Cutaway illustration of Type L (175 Vac, 125 Vdc) secondary arrester.

Table 1. Recommended Applications of Surge Arresters

System Voltage	Type	Rating*
120 volts	L	175 volts
120/240 volts	L	175 volts
120/240 volts Y	L	175 volts
240 volts	S4	650 volts
480 volts	S4	650 volts
600 volts	S4	650 volts
2.4 kVΔ	Protective gap	6 kV
4.16Y/2.4 kV	Protective gap	11 kV
4.8 kVΔ	Protective gap	11 kV
8.32Y/4.8 kV	Protective gap	15 kV
6.9 kVΔ	Protective gap	15 kV
12.47Y/7.2 kV	Protective gap	15 kV
13.2 kVΔ	Protective gap	15 kV
14.4 kVΔ	Protective gap	15 kV

* An arrester rating represents the maximum line-to-ground voltage to which the arrester should be subjected. Since surge arresters are inherently sensitive to overvoltages, they should never be subjected to 60 Hz voltages above their rated voltage, even during momentary abnormal conditions. If such a condition is likely, a special system study may be necessary, and a higher rated arrester may be required.

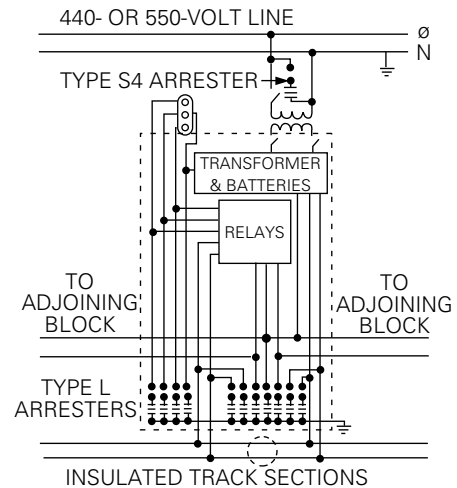

Figure 2. Railway application diagram showing an automatic railway block signal control with Type L secondary arresters. One arrester is used on each outgoing line.

Type L secondary arresters

Operation

Type L arresters protect low-voltage circuits and equipment against surges by providing a low-impedance path to ground, and quickly draining off surge voltages. The arrester promptly restores the circuit to normal by interrupting the 60 Hz current which follows the surge current.

Examples of applications of Type L secondary arresters are shown in Figures 2 and 3.

Standards

Type L arresters meet all requirements for the Association of American Railroads (AAR) Signal Section Specification 52.51.

Impulse sparkover

Uniform sparkover characteristics and a long life are assured by the design of the spark gap of Type L arresters.

60 Hz sparkover

Each Type L arrester is factory tested to assure a minimum 60 Hz sparkover of 1100 volts. This sparkover value allows circuits to be field tested with a 1000-volt megohmmeter without removing the arrester from the circuits.

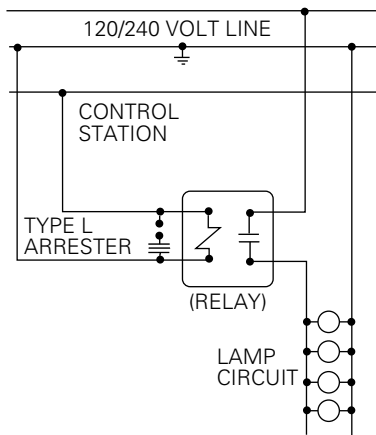

Figure 3. A typical multiple street lighting control circuit showing Type L secondary arresters protecting the relay coil.

Discharge capacity

AAR Specifications require a discharge capacity of 10,000 A on a 4×10^{-6} microsecond wave. Type L arresters have passed certification tests which require discharging two of these surges without damage and complete recovery of all protective characteristics.

Discharge voltage

Low-voltage signal circuit apparatus is designed to withstand a 60 Hz voltage of 4200 volts crest for one minute. Table 2 shows how Type L arresters offer extra protection with very low discharge voltages.

Table 2. Maximum Discharge Voltage (Crest kV) 8/20 μ s Current Wave

Arrester Rating	1.5 kA	3 kA	5 kA	10 kA
175 Vac	1.1	1.2	1.4	1.7
125 Vdc				

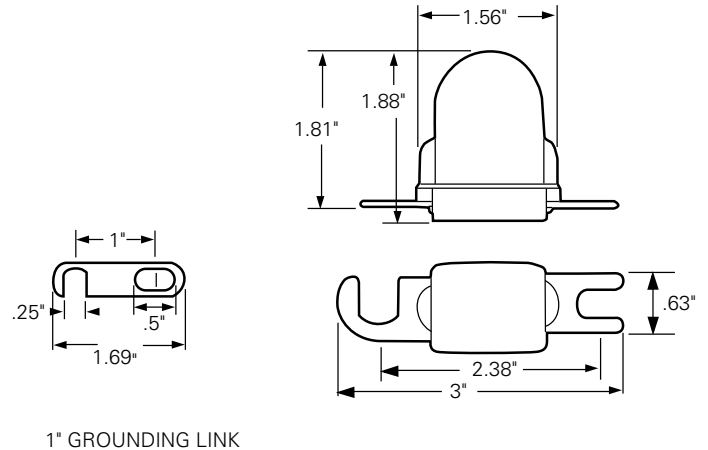

Figure 4. Type L secondary arrester dimensional information.

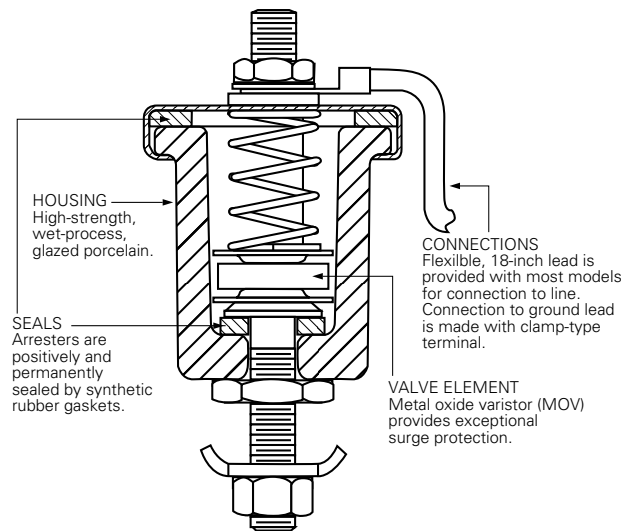

Figure 5. Cutaway illustration Type S4, 650 V secondary arrester.

Duty cycle

Type L arresters subjected to duty-cycle tests of 22 successive impulses of a 1500 A, $8 \times 20 \mu$ s current wave show remarkably consistent characteristics. Follow current is quickly and effectively interrupted.

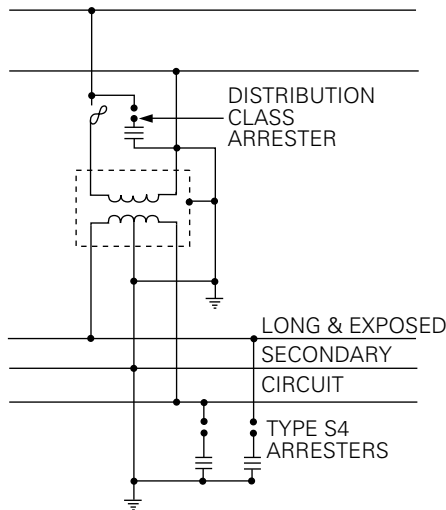

Figure 6. Typical application of Type S4 arresters protecting long and exposed secondary lines in oil field or rural areas.

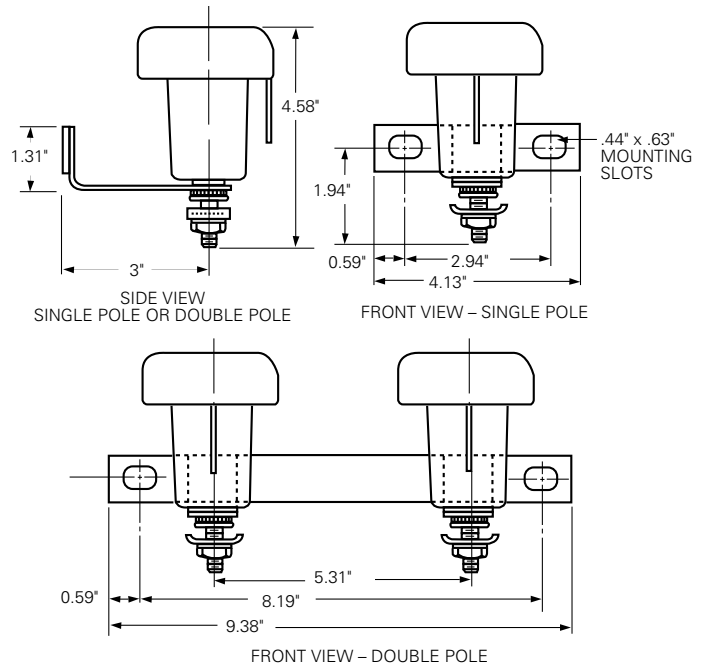

Figure 7. Type S4 secondary arresters dimensional information.

Type S4 secondary arresters

Operation

Type S4 secondary arresters incorporate a gapless MOV design that under steady state conditions maintains the line-to-ground voltage across the arrester's terminals. When overvoltages occur the Type S4 arrester quickly goes into conduction, limiting the overvoltage to required protection levels. Upon passage of the overvoltage condition, the S4 arrester returns to a highly non-linear steady state condition that conducts very minimal 60 Hz power current.

A typical application is shown in Figure 6. Dimensional information is shown in Figure 7.

Discharge voltage

Table 3 shows the discharge-voltage characteristics of the Type S4 arrester.

Table 3. Maximum Discharge Voltage 8/20 μ s Current Wave (kV crest)

Rating	1.5 kA	3 kA	5 kA	10 kA
650 V	2.1	2.4	2.7	3.0

Protective gaps

For interconnection of arrester ground, secondary neutral, and transformer tank

Interconnection provides additional protection to distribution transformers and improves continuity of service to customers. Advantages are particularly evident in areas subjected to extremely heavy lightning surges and/or where soil conditions result in high ground resistance values.

Without interconnection, surge voltage may build up high enough to puncture the transformer insulation. Interconnection limits the potential difference between primary and secondary windings and between the primary winding and the transformer tank to the discharge voltage (IR drop) of the primary arrester, plus the impedance drop in the arrester leads. Many local electrical codes require that interconnection of this type be made through gaps.

For primary neutral protection

If the potential of the primary neutral of a system, grounded only at the substation, is less than 360 rms volts above ground, Eaton's protective gaps provide effective and inexpensive lightning protection. Gaps should be installed between primary neutral and ground at each distribution transformer.

For isolation of transformer tanks from ground

A transformer tank connected to ground through a protective gap is isolated from ground under normal conditions. The gap will spark over and limit the voltage between the transformer tank and windings during high-current lightning discharges.

Sparkover

Protective gaps are permanently adjusted at the factory to spark over at voltages of 6, 11, or 15 kV rms. Arcing surfaces of both electrodes are designed to assure consistent sparkover characteristics.

Table 4. Sparkover Characteristics

System Voltage (kV)	60-Hertz Sparkover (kV rms)	Impulse Sparkover Crest (kV)
2.4 Δ	6	11
4.16Y/2.4, 4.8 Δ	11	17.5
8.32Y/4.8, 6.9 Δ	15	25
12.4Y/7.2	15	25
13.2 Δ, 14.4 Δ	15	25

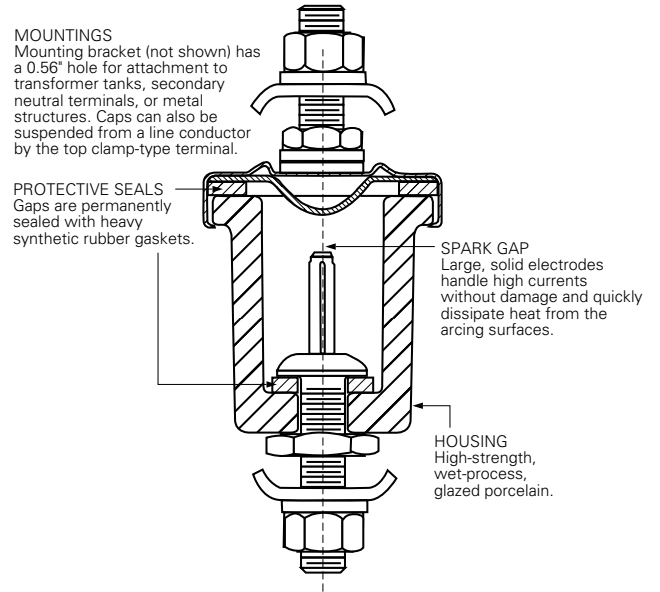

Figure 9. Cutaway illustration of protective gap.

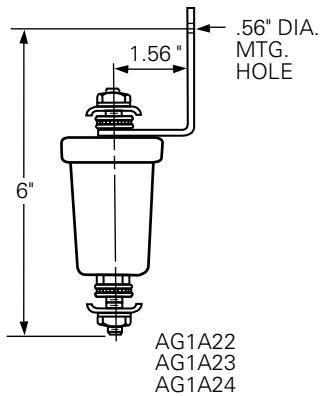

Figure 8. Dimensional Information of protective gaps.

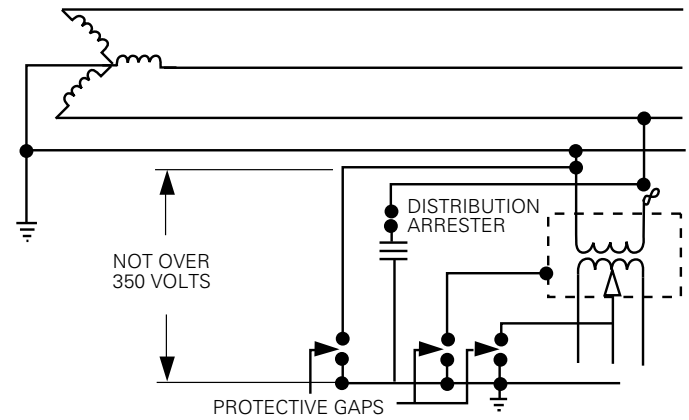

Figure 10. Typical application of protective gaps.

Ordering information

Secondary arresters

Table 5. Type L-Rated 175 Vac, 125 Vdc

Description	Catalog Number	Standard Package	
		Qty.	Wt. of Package (lb.)
Arrester with 1" grounding link	AS1B1	5	5
Arrester only	AS1B2	5	5

Table 6. Protective Gaps - Rated 6, 11, and 15 kV

Description (60 Hz. Sparkover)	Catalog Number	Standard Package	
		Qty.	Wt. of Package (lb.)
6 kV	AG1A22	1	1
11 kV	AG1A23	1	1
15 kV	AG1A24	1	1

Table 7. Type S4 - Rated 650 Vac

Description	Catalog Number	Standard Package	
		Quantity	Wt. of Package (lb.)
Single unit w/o terminal cap, w/o mtg. bracket with line lead	ASZ1A101	1	2
Single unit with terminal cap, w/o mtg. bracket, with line lead	ASZ1A102	1	2
Single unit with terminal cap, with mtg. bracket, with line lead	ASZ1A103	1	2

Eaton
1000 Eaton Boulevard
Cleveland, OH 44122
United States
Eaton.com

Eaton's Cooper Power Systems Division
2300 Badger Drive
Waukesha, WI 53188
United States
Cooperpower.com

© 2015 Eaton
All Rights Reserved
Printed in USA
Publication No. CA235001EN

Eaton and Cooper Power are valuable trademarks of Eaton in the U.S. and other countries. You are not permitted to use these trademarks without the prior written consent of Eaton.

For Eaton's Cooper Power series secondary arresters and protective gaps product information call 1-877-277-4636 or visit: www.cooperpower.com.

Secondary arresters and protective gaps



General information

The necessity of providing surge arrester protection on low-voltage circuits is fundamentally the same as for primary system protection. While secondary lines usually are shorter than primary lines, they still are subject to surges which can cause stresses beyond the insulation withstand strength of connected equipment.

Secondary arresters

Type L

Eaton protects street-lighting controls, low-voltage relays, railroad-signal circuits and circuits used for fire alarms, remote metering and airport lighting with its Cooper Power™ series Type L secondary arresters. They are applicable for voltages up to 175 Vac, or 125 Vdc and are designed for indoor mounting. For general circuit applications refer to Table 1.

Type S4

Eaton provides protection of low-voltage equipment, secondary distribution circuits, control circuits and signal circuits up to 650 Vac with its Cooper Power series Type S4 secondary arresters. These arresters are designed for both indoor and outdoor use and a typical application would be to protect long and exposed secondary systems in oil fields or rural areas.

Protective gaps

Eaton isolates electrical equipment during normal service conditions and provides a path to ground for surge current during arrester operations with its Cooper Power series protective gaps. Protective gaps used for interconnection of arrester ground, secondary neutral, and transformer tank provide additional protection to distribution transformers and improve continuity of service to customers. Protective gaps provide effective and inexpensive surge protection for the primary neutral of a system (grounded only at the substation) if the potential of the primary neutral is less than 350 volts (rms) above ground. Transformer tanks can be isolated from ground under normal conditions by connecting the transformer to ground through a protective gap.

EATON

Powering Business Worldwide

Features and detailed description

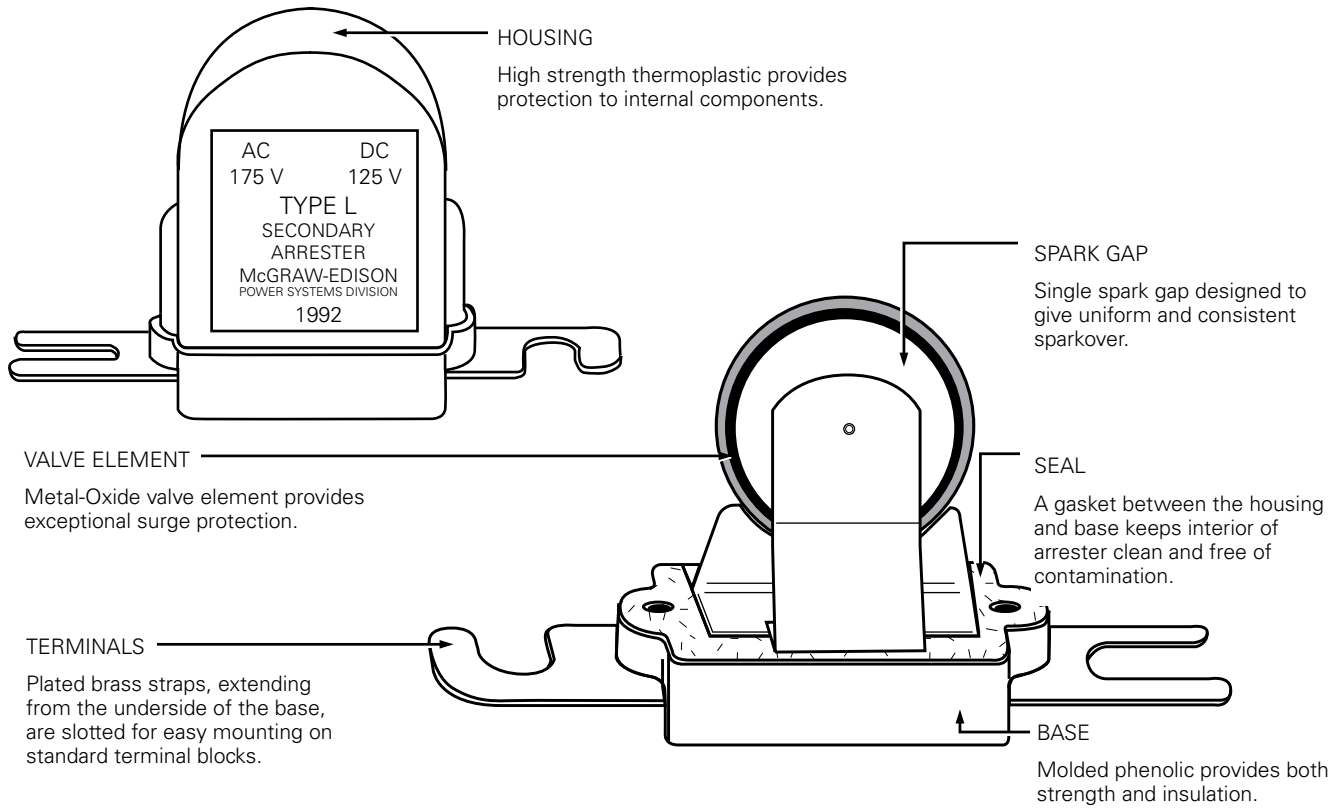

Figure 1. Cutaway illustration of Type L (175 Vac, 125 Vdc) secondary arrester.

Table 1. Recommended Applications of Surge Arresters

System Voltage	Type	Rating*
120 volts	L	175 volts
120/240 volts	L	175 volts
120/240 volts Y	L	175 volts
240 volts	S4	650 volts
480 volts	S4	650 volts
600 volts	S4	650 volts
2.4 kVΔ	Protective gap	6 kV
4.16Y/2.4 kV	Protective gap	11 kV
4.8 kVΔ	Protective gap	11 kV
8.32Y/4.8 kV	Protective gap	15 kV
6.9 kVΔ	Protective gap	15 kV
12.47Y/7.2 kV	Protective gap	15 kV
13.2 kVΔ	Protective gap	15 kV
14.4 kVΔ	Protective gap	15 kV

* An arrester rating represents the maximum line-to-ground voltage to which the arrester should be subjected. Since surge arresters are inherently sensitive to overvoltages, they should never be subjected to 60 Hz voltages above their rated voltage, even during momentary abnormal conditions. If such a condition is likely, a special system study may be necessary, and a higher rated arrester may be required.

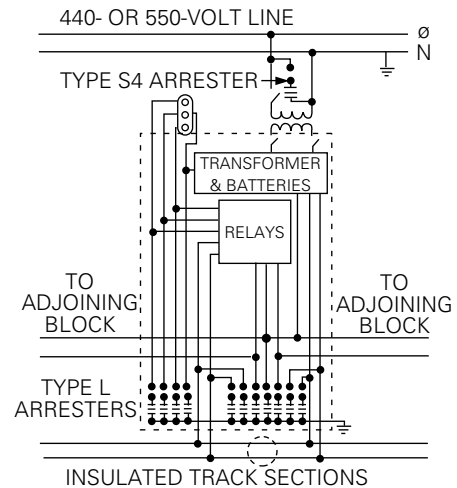

Figure 2. Railway application diagram showing an automatic railway block signal control with Type L secondary arresters. One arrester is used on each outgoing line.

Type L secondary arresters

Operation

Type L arresters protect low-voltage circuits and equipment against surges by providing a low-impedance path to ground, and quickly draining off surge voltages. The arrester promptly restores the circuit to normal by interrupting the 60 Hz current which follows the surge current.

Examples of applications of Type L secondary arresters are shown in Figures 2 and 3.

Standards

Type L arresters meet all requirements for the Association of American Railroads (AAR) Signal Section Specification 52.51.

Impulse sparkover

Uniform sparkover characteristics and a long life are assured by the design of the spark gap of Type L arresters.

60 Hz sparkover

Each Type L arrester is factory tested to assure a minimum 60 Hz sparkover of 1100 volts. This sparkover value allows circuits to be field tested with a 1000-volt megohmmeter without removing the arrester from the circuits.

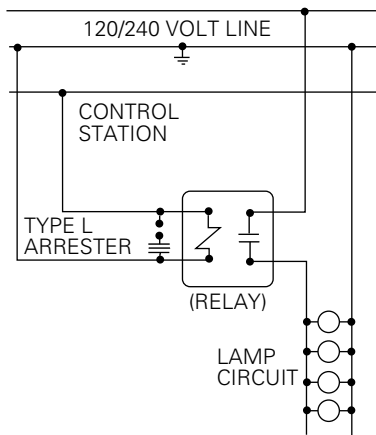

Figure 3. A typical multiple street lighting control circuit showing Type L secondary arresters protecting the relay coil.

Discharge capacity

AAR Specifications require a discharge capacity of 10,000 A on a 4 x 10⁻⁶ microsecond wave. Type L arresters have passed certification tests which require discharging two of these surges without damage and complete recovery of all protective characteristics.

Discharge voltage

Low-voltage signal circuit apparatus is designed to withstand a 60 Hz voltage of 4200 volts crest for one minute. Table 2 shows how Type L arresters offer extra protection with very low discharge voltages.

Table 2. Maximum Discharge Voltage (Crest kV) 8/20 μs Current Wave

Arrester Rating	1.5 kA	3 kA	5 kA	10 kA
175 Vac	1.1	1.2	1.4	1.7
125 Vdc				

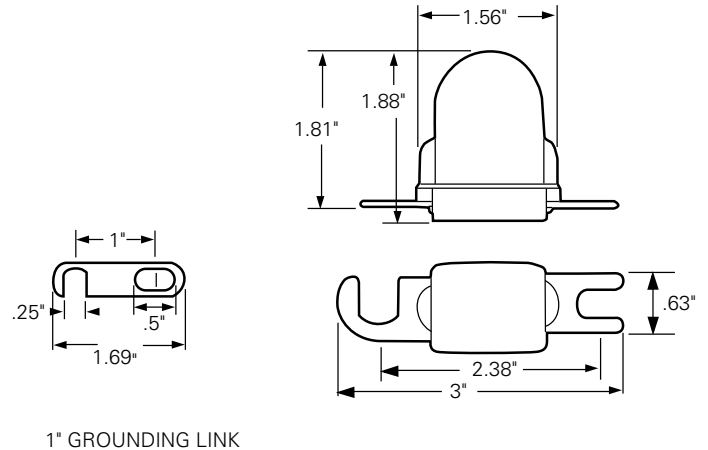

Figure 4. Type L secondary arrester dimensional information.

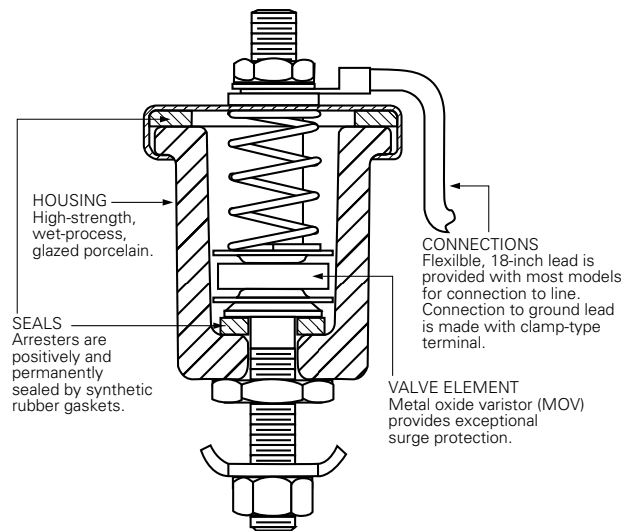

Figure 5. Cutaway illustration Type S4, 650 V secondary arrester.

Duty cycle

Type L arresters subjected to duty-cycle tests of 22 successive impulses of a 1500 A, 8 x 20 μs current wave show remarkably consistent characteristics. Follow current is quickly and effectively interrupted.

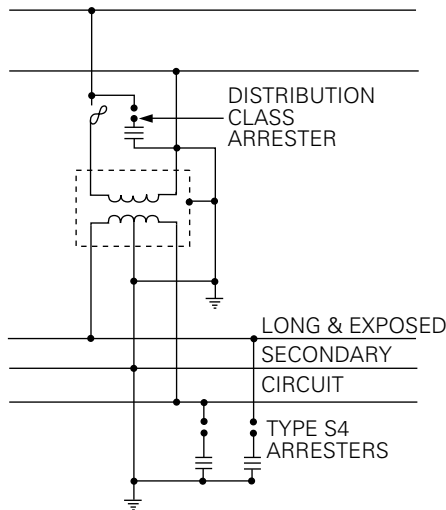

Figure 6. Typical application of Type S4 arresters protecting long and exposed secondary lines in oil field or rural areas.

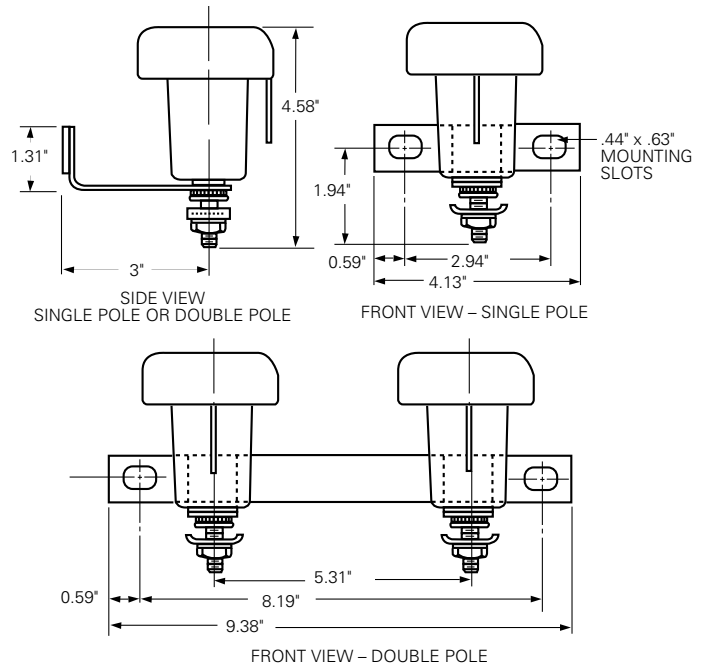

Figure 7. Type S4 secondary arresters dimensional information.

Type S4 secondary arresters

Operation

Type S4 secondary arresters incorporate a gapless MOV design that under steady state conditions maintains the line-to-ground voltage across the arrester's terminals. When overvoltages occur the Type S4 arrester quickly goes into conduction, limiting the overvoltage to required protection levels. Upon passage of the overvoltage condition, the S4 arrester returns to a highly non-linear steady state condition that conducts very minimal 60 Hz power current.

A typical application is shown in Figure 6. Dimensional information is shown in Figure 7.

Discharge voltage

Table 3 shows the discharge-voltage characteristics of the Type S4 arrester.

Table 3. Maximum Discharge Voltage 8/20 μ s Current Wave (kV crest)

Rating	1.5 kA	3 kA	5 kA	10 kA
650 V	2.1	2.4	2.7	3.0

Protective gaps

For interconnection of arrester ground, secondary neutral, and transformer tank

Interconnection provides additional protection to distribution transformers and improves continuity of service to customers. Advantages are particularly evident in areas subjected to extremely heavy lightning surges and/or where soil conditions result in high ground resistance values.

Without interconnection, surge voltage may build up high enough to puncture the transformer insulation. Interconnection limits the potential difference between primary and secondary windings and between the primary winding and the transformer tank to the discharge voltage (IR drop) of the primary arrester, plus the impedance drop in the arrester leads. Many local electrical codes require that interconnection of this type be made through gaps.

For primary neutral protection

If the potential of the primary neutral of a system, grounded only at the substation, is less than 360 rms volts above ground, Eaton's protective gaps provide effective and inexpensive lightning protection. Gaps should be installed between primary neutral and ground at each distribution transformer.

For isolation of transformer tanks from ground

A transformer tank connected to ground through a protective gap is isolated from ground under normal conditions. The gap will spark over and limit the voltage between the transformer tank and windings during high-current lightning discharges.

Sparkover

Protective gaps are permanently adjusted at the factory to spark over at voltages of 6, 11, or 15 kV rms. Arcing surfaces of both electrodes are designed to assure consistent sparkover characteristics.

Table 4. Sparkover Characteristics

System Voltage (kV)	60-Hertz Sparkover (kV rms)	Impulse Sparkover Crest (kV)
2.4 Δ	6	11
4.16Y/2.4, 4.8 Δ	11	17.5
8.32Y/4.8, 6.9 Δ	15	25
12.4Y/7.2	15	25
13.2 Δ, 14.4 Δ	15	25

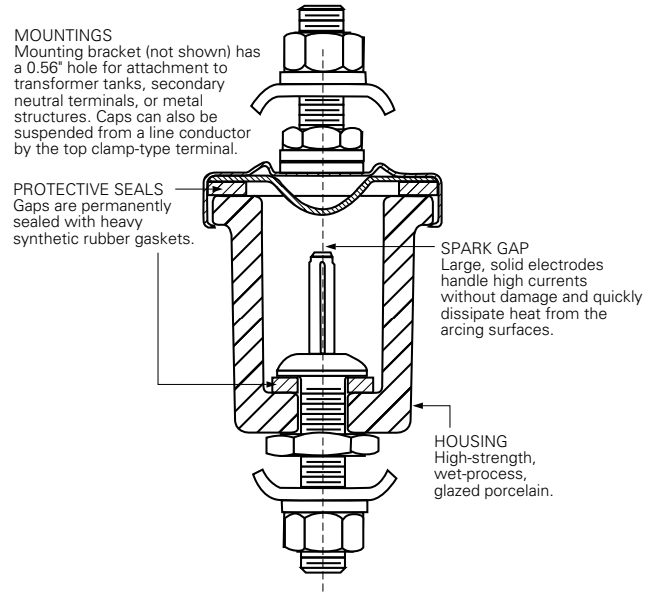

Figure 9. Cutaway illustration of protective gap.

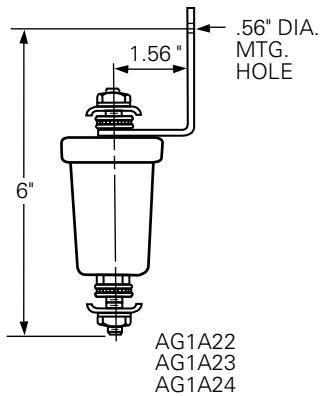

Figure 8. Dimensional Information of protective gaps.

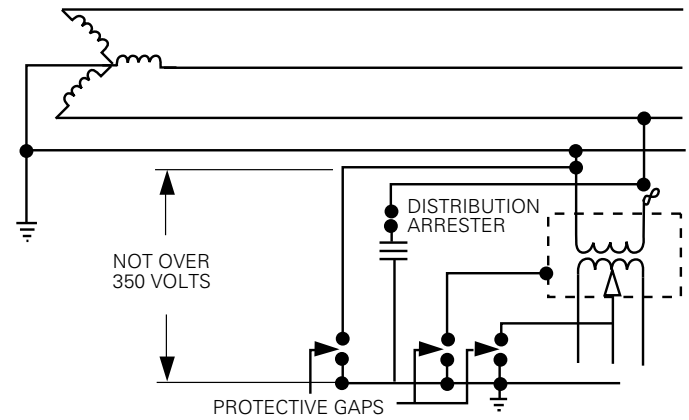

Figure 10. Typical application of protective gaps.

Ordering information**Secondary arresters****Table 5. Type L-Rated 175 Vac, 125 Vdc**

Description	Catalog Number	Standard Package	
		Qty.	Wt. of Package (lb.)
Arrester with 1" grounding link	AS1B1	5	5
Arrester only	AS1B2	5	5

Table 6. Protective Gaps - Rated 6, 11, and 15 kV

Description (60 Hz. Sparkover)	Catalog Number	Standard Package	
		Qty.	Wt. of Package (lb.)
6 kV	AG1A22	1	1
11 kV	AG1A23	1	1
15 kV	AG1A24	1	1

Table 7. Type S4 - Rated 650 Vac

Description	Catalog Number	Standard Package	
		Quantity	Wt. of Package (lb.)
Single unit w/o terminal cap, w/o mtg. bracket with line lead	ASZ1A101	1	2
Single unit with terminal cap, w/o mtg. bracket, with line lead	ASZ1A102	1	2
Single unit with terminal cap, with mtg. bracket, with line lead	ASZ1A103	1	2

Eaton
1000 Eaton Boulevard
Cleveland, OH 44122
United States
Eaton.com

Eaton's Cooper Power Systems Division
2300 Badger Drive
Waukesha, WI 53188
United States
Cooperpower.com

© 2015 Eaton
All Rights Reserved
Printed in USA
Publication No. CA235001EN

Eaton and Cooper Power are valuable trademarks of Eaton in the U.S. and other countries. You are not permitted to use these trademarks without the prior written consent of Eaton.

For Eaton's Cooper Power series secondary arresters and protective gaps product information call 1-877-277-4636 or visit: www.cooperpower.com.