

B441-22 Beam Clamp

- Design Load 1200 Lbs. (5.34 kN) when used in pairs
- Safety Factor of 5
- $\frac{3}{4}$ " (19.0) Max. Flange Thickness
- For use with $\frac{13}{16}$ " (20.6) to $\frac{15}{8}$ " (41.3) high channel
- Recommended Torque: 150 in-lbs. (16.9 N•m)
- Sold in pieces
- Other flange thickness variations are available, contact us for sizes
- Standard finishes: ZN, HDG, SS4
- Wt./C 87 Lbs. (39.4 kg)

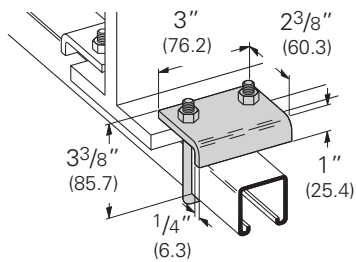

B441-22A Beam Clamp

- Design Load 1200 Lbs. (5.34 kN) when used in pairs
- Safety Factor of 5
- $\frac{3}{4}$ " (19.0) Max. Flange Thickness
- For use with $\frac{15}{8}$ " (41.3) to $3\frac{1}{4}$ " (82.5) high channel
- Recommended Torque: 150 in-lbs. (16.9 N•m)
- Sold in pieces
- Other flange thickness variations are available, contact us for sizes
- Standard finishes: ZN, HDG, SS4
- Wt./C 93 Lbs. (42.2 kg)

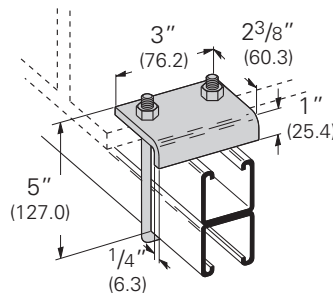

B314 Beam Clamp

- Design Load 900 Lbs. (4.00 kN) when used in pairs
- Safety Factor of 5
- $\frac{5}{8}$ " (15.9) Max. Flange Thickness
- For use with channel $\frac{15}{8}$ " (41.3) in height
- Setscrew included
- Sold in pieces
- Standard finishes: ZN, GRN, HDG, SS4
- Wt./C 105 Lbs. (47.6 kg)

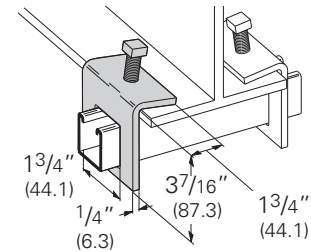

B441Z-22 Beam Clamp

- Design Load 1200 Lbs. (5.34 kN) when used in series
- Safety Factor of 5
- Sold in pieces
- For use with $\frac{13}{16}$ " (20.6) to $\frac{15}{8}$ " (41.3) high channel
- Recommended Torque: 150 in-lbs. (16.9 N•m)
- Standard finishes: ZN
- Wt./C 95 Lbs. (43.1 kg)

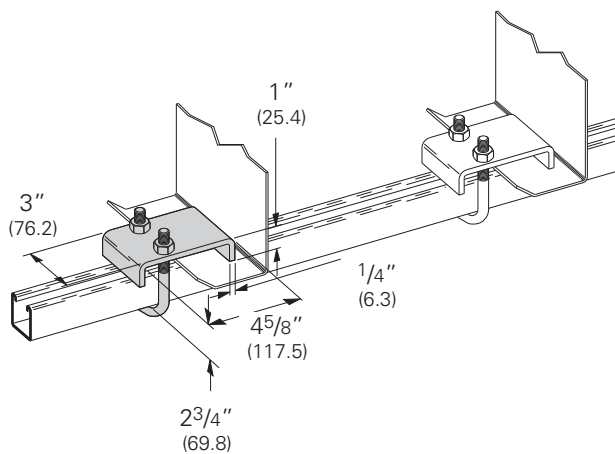

B441Z-22A Beam Clamp

- Design Load 1200 Lbs. (5.34 kN) when used in series
- Safety Factor of 5
- Sold in pieces
- For use with $\frac{15}{8}$ " (41.3) to $3\frac{1}{4}$ " (82.5) high channel
- Recommended Torque: 150 in-lbs. (16.9 N•m)
- Standard finishes: ZN
- Wt./C 101 Lbs. (45.8 kg)

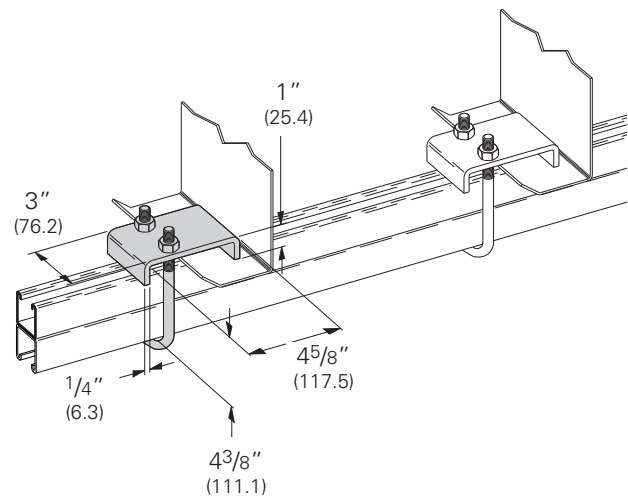

Reference page 113 for general fitting and standard finish specifications.

B441-22 Beam Clamp

- Design Load 1200 Lbs. (5.34 kN) when used in pairs
- Safety Factor of 5
- $\frac{3}{4}$ " (19.0) Max. Flange Thickness
- For use with $\frac{13}{16}$ " (20.6) to $1\frac{5}{8}$ " (41.3) high channel
- Recommended Torque: 150 in-lbs. (16.9 N•m)
- Sold in pieces
- Other flange thickness variations are available, contact us for sizes
- Standard finishes: ZN, HDG, SS4
- Wt./C 87 Lbs. (39.4 kg)

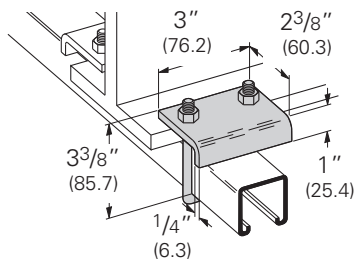

B441-22A Beam Clamp

- Design Load 1200 Lbs. (5.34 kN) when used in pairs
- Safety Factor of 5
- $\frac{3}{4}$ " (19.0) Max. Flange Thickness
- For use with $1\frac{5}{8}$ " (41.3) to $3\frac{1}{4}$ " (82.5) high channel
- Recommended Torque: 150 in-lbs. (16.9 N•m)
- Sold in pieces
- Other flange thickness variations are available, contact us for sizes
- Standard finishes: ZN, HDG, SS4
- Wt./C 93 Lbs. (42.2 kg)

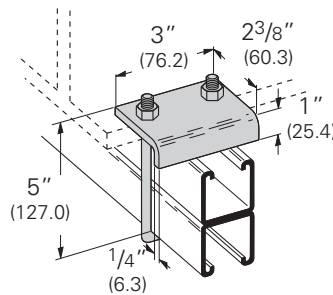

B314 Beam Clamp

- Design Load 900 Lbs. (4.00 kN) when used in pairs
- Safety Factor of 5
- $\frac{5}{8}$ " (15.9) Max. Flange Thickness
- For use with channel $1\frac{5}{8}$ " (41.3) in height
- Setscrew included
- Sold in pieces
- Standard finishes: ZN, GRN, HDG, SS4
- Wt./C 105 Lbs. (47.6 kg)

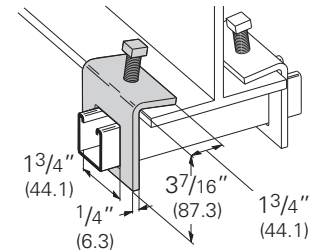

B441Z-22 Beam Clamp

- Design Load 1200 Lbs. (5.34 kN) when used in series
- Safety Factor of 5
- Sold in pieces
- For use with $\frac{13}{16}$ " (20.6) to $1\frac{5}{8}$ " (41.3) high channel
- Recommended Torque: 150 in-lbs. (16.9 N•m)
- Standard finishes: ZN
- Wt./C 95 Lbs. (43.1 kg)

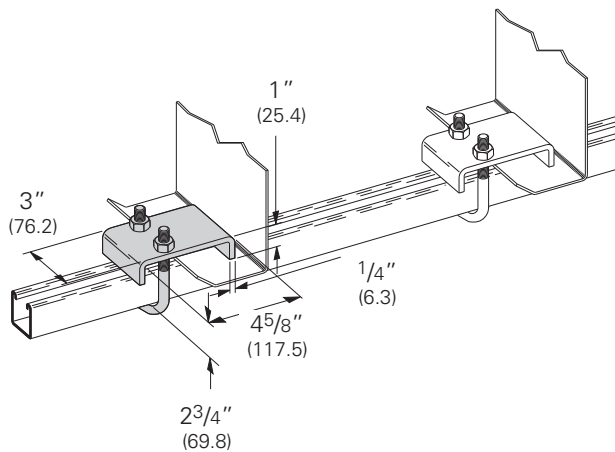

B441Z-22A Beam Clamp

- Design Load 1200 Lbs. (5.34 kN) when used in series
- Safety Factor of 5
- Sold in pieces
- For use with $1\frac{5}{8}$ " (41.3) to $3\frac{1}{4}$ " (82.5) high channel
- Recommended Torque: 150 in-lbs. (16.9 N•m)
- Standard finishes: ZN
- Wt./C 101 Lbs. (45.8 kg)

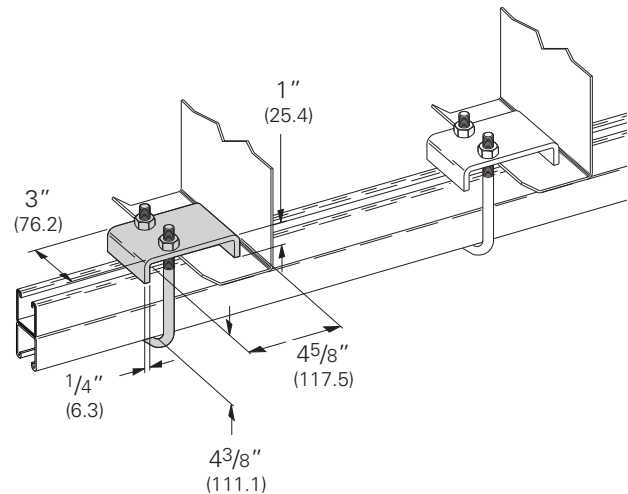

Reference page 113 for general fitting and standard finish specifications.