

Cat. #		Approvals
Job	Type	

APPLICATIONS

- Warehouses, workshops, auto maintenance, factories, etc.
- For applications with ceiling heights of 15-30 ft

SPECIFICATIONS

- Die-cast housing with protective white powder paint finish
- Easy wiring hanger for 3/4" conduit
- Cast safety hook included for hanging
- 400 watt metal halide, 120/208/240/277 volt, HPF CWA ballast
- Lamp included
- Unit pack
- 16" aluminum reflector with white powder paint finish for corrosion resistance and uniform distribution.
- Drop acrylic refractor and clamp band allow use with standard, stock metal halide lamps. Provides lamp image shielding from below.

LISTINGS

- UL listed for use in damp locations.

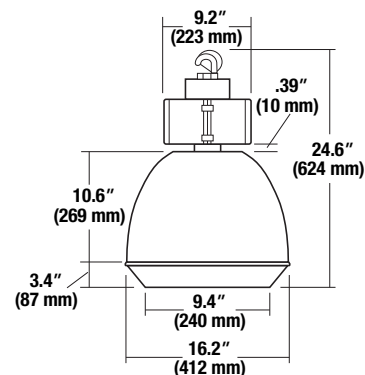

ORDERING INFORMATION

Catalog Number	Description
BL-400P-LB	Lowbay Unit Pack, 400 watt PSMH, Multi-Tap w/ optic, lamp, & hook
BL-400P-LB-Q	Lowbay Unit Pack, 400 watt PSMH, Multi-Tap w/ optic, lamp, & hook - QSS

Due to our continued efforts to improve our products, product specifications are subject to change without notice.



Industrial Lighting

Hubbell Industrial Lighting • 701 Millennium Boulevard • Greenville, SC 29607 • PHONE: 864-678-1000

For more information visit our web site: www.hubbell-ltg.com

Cat. #		Approvals
Job	Type	



APPLICATIONS

- Warehouses, workshops, auto maintenance, factories, etc.
- For applications with ceiling heights of 15-30 ft

SPECIFICATIONS

- Die-cast housing with protective white powder paint finish
- Easy wiring hanger for 3/4" conduit
- Cast safety hook included for hanging
- 400 watt metal halide, 120/208/240/277 volt, HPF CWA ballast
- Lamp included
- Unit pack
- 16" aluminum reflector with white powder paint finish for corrosion resistance and uniform distribution.
- Drop acrylic refractor and clamp band allow use with standard, stock metal halide lamps. Provides lamp image shielding from below.

LISTINGS

- UL listed for use in damp locations.

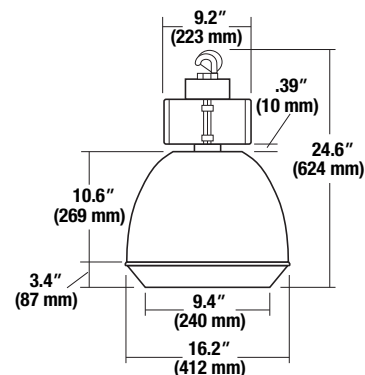

ORDERING INFORMATION

Catalog Number	Description
BL-400P-LB	Lowbay Unit Pack, 400 watt PSMH, Multi-Tap w/ optic, lamp, & hook
BL-400P-LB-Q	Lowbay Unit Pack, 400 watt PSMH, Multi-Tap w/ optic, lamp, & hook - QSS

Due to our continued efforts to improve our products, product specifications are subject to change without notice.



Industrial Lighting

Hubbell Industrial Lighting • 701 Millennium Boulevard • Greenville, SC 29607 • PHONE: 864-678-1000

For more information visit our web site: www.hubbell-ltg.com