

**Type 3R Industrial Pump Panel—
C440 SSOL**



Narrow Enclosure Pump Panel



Irrigation Pump Panel—C440 SSOL



A200 Pump Panel



6.1 Industrial Pump Panels	
Product Overview	V10-T6-2
Freedom—Fusible Disconnect	V10-T6-7
Freedom—Circuit Breaker	V10-T6-9
A200—Fusible Disconnect	V10-T6-11
A200—Circuit Breaker	V10-T6-13
6.2 Vacuum Starter Pump Panels	
Freedom—Fusible Disconnect and Circuit Breaker	
Product Description	V10-T6-15
Standards and Certifications	V10-T6-15
Additional Reference	V10-T6-15
Product Selection	V10-T6-16
Wiring Diagram	V10-T6-16
6.3 Irrigation Pump Panels	
Product Description	V10-T6-17
Features	V10-T6-17
Standards and Certifications	V10-T6-17
Additional Reference	V10-T6-17
Catalog Number Selection	V10-T6-18
Pump Panels—Interchangeable Heater Overload	V10-T6-19
Pump Panels—Solid-State Overload	V10-T6-20
6.4 Duplex Pump Panels	
Product Description	V10-T6-23
Standards and Certifications	V10-T6-23
Additional Reference	V10-T6-23
Catalog Number Selection	V10-T6-24
Cover Control	V10-T6-25
Non-Combination	V10-T6-26
Combination	V10-T6-27

Industrial Pump Panels



6

Product Overview

Product Description

Eaton's pump controllers are combination starters with accessories and modifications designed to meet the particular requirements of the irrigation, oil well, gas and other pump application industries. The enclosure is Type 3R to provide weather-tight protection and is available in several sizes, depending on the customer's control option requirements. The disconnect, contactor and overload relay are the same as used in Freedom lines of combination starters. These controllers are available in standard full voltage as well as reduced voltage configurations, with vacuum contactors as well as the standard electromechanical contactors.

Eaton's revolutionary design for soft starters is shown in the S801+ and S811+ soft starter products which are members of the Intelligent Technologies (*IT.*) family of products. These reduced voltage soft starters are the most compact, multi-functional, easy-to-install products on the market. Their superiority begins with the control package, which features 24 Vdc control, onboard Digital Signal Processor (DSP), and use of a low impedance run contactor, all of which contribute to the *IT.* soft starter's safety, advanced functionality and compact size.

Contents

Description

	<i>Page</i>
Industrial Pump Panels	
Standards and Certifications	V10-T6-3
Additional Reference	V10-T6-3
Catalog Number Selection	V10-T6-4
Accessories	V10-T6-5
Freedom—Fusible Disconnect	V10-T6-7
Freedom—Circuit Breaker	V10-T6-9
A200—Fusible Disconnect	V10-T6-11
A200—Circuit Breaker	V10-T6-13

Features

The Freedom series starters are available in either fusible or circuit breaker types utilizing Type 3R rainproof and sleet resistant enclosures. Convenient straight-through wiring with top line connections and bottom load connections features easily accessible pressure connections for line, load and control. Starter and disconnect are factory wired.

- Motor Circuit Switch**—Long life, heavy-duty, quick acting, double break action. Positive ON and positive OFF available in either fusible or non-fusible versions. Fuse clip kits are available for field installation and can be converted in the field for maximum job flexibility
- Motor Circuit Protector**—Similar to a magnetic trip only circuit breaker. Features an adjustable magnetic trip characteristic for accurate, dependable fault protection and simultaneous trip of all poles to prevent single phasing
- Overload Relay**—Freedom overload relays with trip indication feature bimetallic type operation with ambient compensation and a choice of either manual or automatic reset
C440 electronic overload relays are available up to 100A as a self-powered, self-contained unit. With external CTs, C440 can protect motor up to 1500 FLA. Available add-on accessories include remote reset capability and communication modules with I/O for DeviceNet, PROFIBUS, and Modbus.
- HAND/OFF/AUTO Selector Switch and START Pushbutton**—10250T heavy-duty units mounted on the flange of the enclosure for outside accessibility
- RESET Button**—Accessible from front of enclosure (booted for environmental protection) for operation of overload relay reset function

- **Enclosure**—Type 3R rainproof and sleet resistant construction with stainless steel door latches and special corrosion resistant paint. Enclosure features include grounding lugs, padlocking feature on door latch, drip hood over door and provisions for top mounting conduit hubs. Most enclosures include generous panel space for mounting optional control and accessories
- **Mounting**—Pole mounting feet with keyhole slots for easy mounting are standard on enclosures for Sizes 1–5 (removable for Sizes 1–5 standard width flange type enclosures). Brackets can be formed to the contour of the pole after mounting
- **Padlocking**—Provision on door latch for locking door closed, as well as provision for padlocking disconnect switch in OFF position. With a simple modification, disconnect can also be padlocked in ON position
- **UL Listed**—Underwriters Laboratories Inc. includes the “Suitable for Use as Service Equipment” label

Interrupting Ratings

- **Fusible**—Sizes 1–5 suitable for use on a circuit capable of delivering not more than 100,000 rms symmetrical amperes. 600V maximum where a Class R fuse clip kit is properly installed and Class R fuses are used. If Class R fuses are not used, the switch should not be installed on circuits capable of delivering more than 10,000 rms symmetrical amperes. Size 6 is limited to 18,000 and Size 7 is limited to 30,000 rms symmetrical amperes
- **Circuit Breaker**—Sizes 1–3 controllers are suitable for use on circuits capable of delivering not more than 100,000 rms symmetrical amperes at 480V maximum; for 600V applications not more than 65,000 rms symmetrical amperes
- **ECP Irrigation Pump Panel**—Suitable for use on circuits capable of delivering not more than 10,000 rms symmetrical amperes at 480V maximum

Optional Features

- **Backspin Timer**—0.2 seconds to 3 minutes. Prevents restart until motor and pump have stopped
- **Program Timer**—24 hour, 7 day with day omission
- **Control Transformer**—Available as standard, either as a field kit or factory installed. Includes two primary and one secondary fuses
- **Electrical Interlocks**—Side mounted in NO, NC and NO-NC. Maximum of two contacts on either side of starter through Size 2, maximum of three per side Sizes 3–5
- **Control Circuit Fuse Kit**—30A, 600V rating
- **Lightning Arrestor**—Offers protection to control from lightning induced surges
- **“R” Fuse Clip Kits**—30–200A, 250V and 600V ratings
- **Disconnect Control Circuit Interlock**—To disconnect separate control circuits

- **Enclosure Conduit Hubs**—Hole provided in enclosure top covered with hole closer. Will accept 3/4 in, 1-1/4 in, 1-1/2 in, 2 in, 2-1/2 in, and three inch conduit sizes
- **Pad Mounting Feet**—For standard width enclosures Sizes 1–5
- **Electronic Overload (SSOL)**
- **304-Grade Stainless Steel Enclosure**—For additional corrosion resistance, any of the pump panels can be ordered as 304-Grade stainless steel, still keeping the Type 3R rating
- **Soft Starter Pump Control Options**
 - Designed to reduce “water-hammer” during start-up and stopping sequences
 - Stop ramp extended to 60 seconds to help control larger motors and systems with long piping runs

Standards and Certifications

Note: See **Tab 17** for additional information on standards and certifications that apply to all enclosed control products.

- UL Listed
- cUL Listed (indicates appropriate CSA Standard investigation)
- ABS Type Approved
- OSHPD Certified (OSP-0015-10)

Additional Reference

Kits	V10-T6-5
Dimensions	Tab 14
Accessories and Modifications	Tab 15
Technical Data and Specifications	Tab 17

6.1

Pump Panels

Industrial Pump Panels

Catalog Number Selection

Pump Panel

6

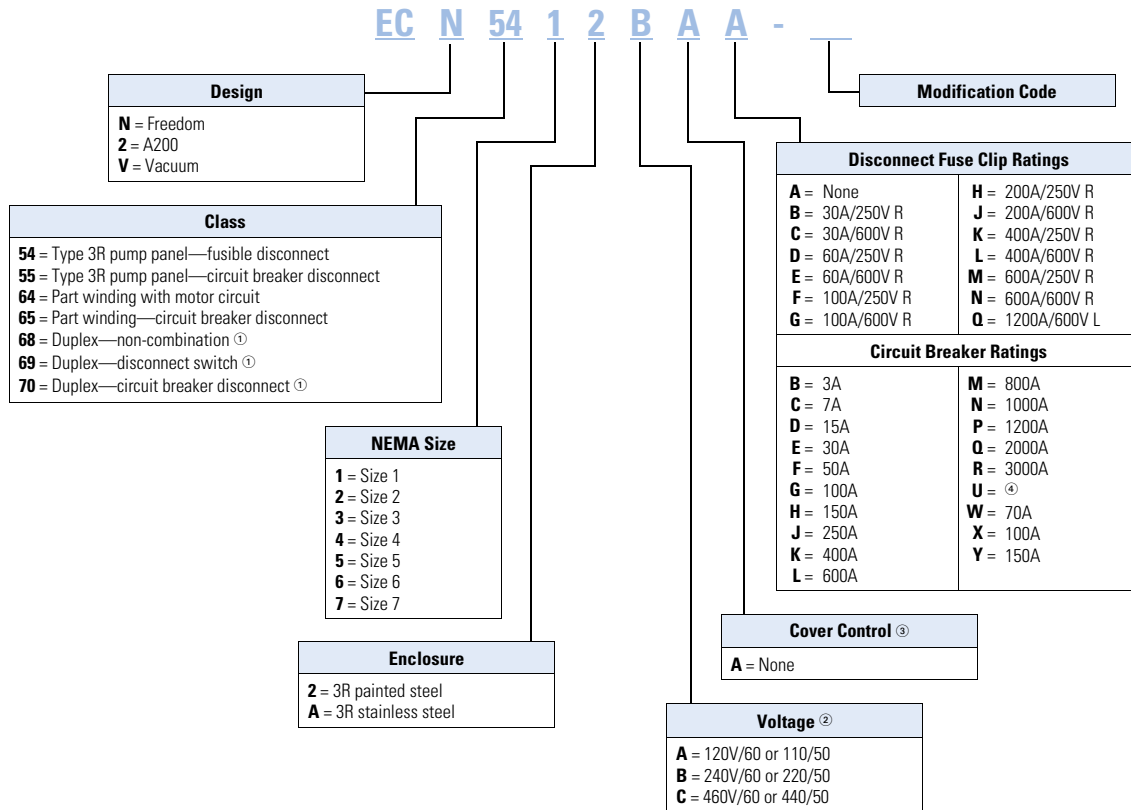

Notes

- ① More information on Type 1, 3R, 4X and 12 duplex pump panels is on **Page V10-T6-23**. Product Selection is on **Page V10-T6-26**.
- ② For other voltages and single-phase applications, consult your Eaton representative.
- ③ HOA selector switch and START pushbutton provided as standard.
- ④ Engineering determination depending on size, horsepower FLA, NEC or other considerations.

Accessories

Kits

Kits for Field Mounting

Description	Catalog Number Suffix	Catalog Number
Backspin timer—0.2 sec. to 3 min. (60 Hz)	B12	—
Control transformers 240/480V primary, 120V secondary		
Size 1	C1	—
Size 2	C1	—
Size 3	C1	—
Size 4	C1	—
Size 5	C1	—
Lightning arrestor	L3	—
Control circuit fuse kit (600V)	C31	—
Electrical interlocks—Freedom line/vacuum		
NO	A27	—
NC	A28	C320KGS2
NO and NC	A29	C320KGS3
Time delay relay—3 minutes		
ON delay (unwired)	T6	—
OFF delay (unwired)	T7	—
24-hour programming clock	P44	—
Interchangeable hubs for enclosure. ^①		
Enclosure has removable top plate. If conduit hub is required, order:		
3/4 in conduit size	—	DS075H1
1-1/4 in conduit size	—	DS125H1
1-1/2 in conduit size	—	DS150H1
2 in conduit size	—	DS200H1
2-1/2 in conduit size	—	DS250H2
3 in conduit size	—	DS300H2
Power supply	C34	—

Note

^① Does not apply to reduced voltage controllers.

Overload Relays**Freedom Solid-State Overload Relays**

NEMA Size	Full Load Current Adjustment Range (A)	Three-Phase without Ground Fault Auto/Manual Reset Overload Selectable Class 10/20/30	Three-Phase with Ground Fault Auto/Manual Reset Overload Selectable Class 10/20/30
00	0.33–1.65 ^①	R63/A	R64/A
	1–5	R63/B	R64/B
	4–20	R63/C	R64/C
0 and 1	0.33–1.65 ^①	R63/A	R64/A
	1–5	R63/B	R64/B
	4–20	R63/C	R64/C
	9–45	R63/D	R64/D
2	9–45	R63/D	R64/D
3	20–100	R63/E	R64/E
4	28–140	R63/F	R64/F
5	60–300 ^②	R63/G	R64/G
6	120–600 ^③	R63/H	R64/H

Notes

- ^① Not UL Listed.
- ^② NEMA Size 5 starter available with 60–300A panel mounted CTs. Starter as an assembled unit with 1–5A C440 overload relay (C440A1A005SELAX or C440A2A005SELAX).
- ^③ NEMA Size 6 starter available with 120–600A panel mounted CTs. Starter as an assembled unit with 1–5A C440 overload relay (C440A1A005SELAX or C440A2A005SELAX).

Freedom—Fusible Disconnect

Product Description

- Three-phase magnetic
- Interchangeable heater OLR

Standard ECN54 controllers have a HAND/OFF/AUTO selector switch and START and RESET pushbuttons mounted on the enclosure and are wired as illustrated on **Page V10-T6-8**.

Type 3R enclosure does not include top conduit hubs. Hubs are available in kit form—see **Page V10-T6-5**.

If branch circuit protective device is 45A or greater, C320FBR1 fuse kit (panel mounted) may be required for control circuit protection per NEC 430-72.

Stainless steel enclosure may be ordered by changing the seventh digit to **A**. Type 3R rating will still apply.

Product Selection

Class ECN54—Combination Pump Panel—Fusible Disconnect

NEMA Size	Motor Voltage ①	Max. hp 50/60 Hz	Fuse Clip Rating ②		Narrow Width ③	Standard Width ③
			Amperes	Volts	Catalog Number	Catalog Number
1 ④	230	7-1/2	30	250	ECN5412BAB-E14	ECN5412BAB
	460	10		600	ECN5412CAC-E14	ECN5412CAC
	—	—	Not installed	Not installed	ECN5412AAA-E14	ECN5412AAA
2	230	15	60	250	ECN5422BAD-E14	ECN5422BAD
	460	25		600	ECN5422CAE-E14	ECN5422CAE
	—	—	Not installed	Not installed	ECN5422AAA-E14	ECN5422AAA
3	230	30	100	250	—	ECN5432BAF
	460	50		600	—	ECN5432CAG
	—	—	Not installed	Not installed	—	ECN5432AAA
4 ④	230	50	200	250	—	ECN5442BAH
	460	100		600	—	ECN5442CAJ
	—	—	Not installed	Not installed	—	ECN5442AAA
5	230	100	400	250	—	ECN5452BAK
	460	200		600	—	ECN5452CAL
6	230	200	600	250	—	ECN5462BAM
	460	400		600	—	ECN5462CAN
7	460	600	1200	600	—	ECN5472CAQ

Notes

Starters do not include heater packs. Select one carton of three heater packs. For heater pack selection, see **Tab 15**.

Starters with electronic overload, see Modification Codes in **Tab 15**.

① Dual element fuse ratings.

② Class R fuse clips, except for Size 7 which uses Class L fuse clips. For starters with clips “Not Installed,” select fuse clip kit on **Page V10-T6-8**.

③ To order without the START pushbutton, add modification code **P6**.

④ For Compact NEMA Size 1 or Size 4 Pump Panel, add modification code **C60**. (Example: ECN5412AAA-C60).

Compact NEMA Size 1 and Size 4 Starters Electrical Life at Rated Continuous Current

NEMA Size	Rated Current (Amp) AC3/AC4	Operations
1C	27/150	2,500,000/40,000
1	27/153	5,000,000/110,000
4C	135/516	500,000/40,000
4	135/822	800,000/70,000

For Other Volts and Hertz Applications

For other than listed volts and hertz, select required controller by catalog number and replace the magnet coil alpha designation, eighth digit in catalog number, with proper code suffix from the table below.

Example: For 600V 60 Hz coil, change ECN5412**B**AC to ECN5412**D**AC.

Coil Voltage

Coil Volts and Hertz	Suffix Code
120/60 or 110/50	A
240/60 or 220/50	B
480/60 or 440/50	C
600/60 or 550/50	D
208/60	E

Accessories

C351—Fuse Clip Selection—Three-Pole (Three Fuses)

NEMA Size	Motor Voltage	Fuse Clip Rating Amperes	Volts	Fuse Clip Kit for Field Installation in Non-Fusible Starter	
				For Non-Rejection Type Fuses Catalog Number	For Use with "R" Rejection Type Fuses Catalog Number
1	200/230	30	250	C351KC21	C351KC21R
	460-575		600	C351KD22-61	C351KD22-61R
2	200	60	250	C351KD22-61	C351KD22-61R
	230		250	C351KD22-61	C351KD22-61R
	460-575		600	C351KD62	C351KD62R
3	200	100	250	C351KE23-63	C351KE23-63 ①
	230		250	C351KE23-63	C351KE23-63 ①
	460-575		600	C351KE23-63	C351KE23-63 ①
4	200	200	250	C351KF24-64	C351KF24-64 ①
	230		250	C351KF24-64	C351KF24-64 ①
	460-575		600	C351KF24-64	C351KF24-64 ①

Note

① Fuse clip "R" rejection members for use with Class R fuses are supplied loose both in fuse clip kits and when fuse clips are factory installed.

Wiring Diagram

Typical Wiring Diagram

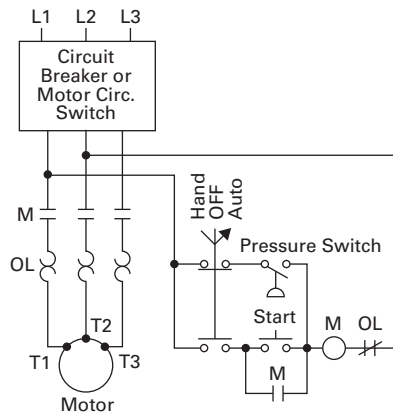

Freedom—Circuit Breaker

Product Description

- Three-phase magnetic
- Interchangeable heater OLR

These ECN55 pump controllers feature the Freedom line starters. They have a HAND/OFF/AUTO selector switch and START pushbutton mounted on the

enclosure and a RESET button on the front—wiring is as illustrated in the wiring diagram on **Page V10-T6-8**.

Type 3R enclosure does not include top conduit hubs. Hubs are available in kit form—see table on **Page V10-T6-5**.

If branch circuit protective device is 45A or greater, C320FBR1 fuse kit (panel mounted) may be required for control circuit protection per NEC 430-72.

Stainless steel enclosure may be ordered by changing the seventh digit to **A**. Type 3R rating will still apply.

Product Selection

Class ECN55—Combination Pump Panel—Circuit Breaker

NEMA Size	Motor Voltage	Max. hp 50/60 Hz	Circuit Breaker Size	Narrow Width ^① Catalog Number	Standard Width ^① Catalog Number
1 ^②	230	1	7A	ECN5512BAC-E14	ECN5512BAC
		3	15A	ECN5512BAD-E14	ECN5512BAD
		7-1/2	30A	ECN5512BAE-E14	ECN5512BAE
	460	1	3A	ECN5512CAB-E14	ECN5512CAB
		3	7A	ECN5512CAC-E14	ECN5512CAC
		5	15A	ECN5512CAD-E14	ECN5512CAD
2	230	10	50A	ECN5522BAF-E14	ECN5522BAF
	460	25		ECN5522CAF-E14	ECN5522CAF
3	230	30	100A	—	ECN5532BAG
	460	50		—	ECN5532CAG
4 ^②	230	50	150A	—	ECN5542BAH
	460	100		—	ECN5542CAH
5	230	60	250A	—	ECN5552BAJ
	230	100	400A	—	ECN5552BAK
	460	150	250A	—	ECN5552CAJ
	460	200	400A	—	ECN5552CAK
6	230	125	600A	—	ECN5562BAL
	230	200	800A	—	ECN5562BAM
	460	300	600A	—	ECN5562CAL
	460	400	800A	—	ECN5562CAM
7	230	250	^③	—	ECN5572BAU
	230	300		—	ECN5572BAU
	460	500		—	ECN5572CAU
	460	600		—	ECN5572CAU

Notes

Starters do not include heater packs. Select one carton of three heater packs. For heater pack selection, see **Tab 15**.

^① To order without the START pushbutton, add modification code **P6**.

^② For Compact NEMA Size 1 or Size 4 Pump Panel, add modification code **C60**. (Example: ECN5412AAA-C60).

**Compact NEMA Size 1 and Size 4 Starters
Electrical Life at Rated Continuous Current**

NEMA Size	Rated Current (Amp) AC3/AC4	Operations
1C	27/150	2,500,000/40,000
1	27/153	5,000,000/110,000
4C	135/516	500,000/40,000
4	135/822	800,000/70,000

^③ Supply hp, voltage, FLA and whether motor is design E or not when ordering the starter.

For Other Volts and Hertz Applications

For other than listed volts and hertz, select required controller by catalog number and replace the magnet coil alpha designation, eighth digit in catalog number, with proper code suffix from the table below.

Example: For 600V 60 Hz coil, change ECN5512**C**AC to ECN5512**D**AC.

Coil Voltage

Coil Volts and Hertz	Suffix Code
120/60 or 110/50	A
240/60 or 220/50	B
480/60 or 440/50	C
600/60 or 550/50	D
208/60	E

6.1

Pump Panels

Industrial Pump Panels

Dimensions

Approximate Dimensions in Inches (mm)

Panel Space

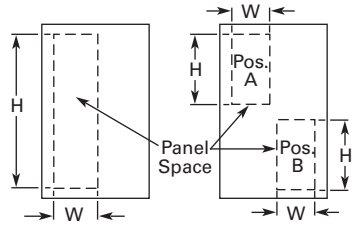

NEMA Sizes 1-4

NEMA Size 5

Panel Size	NEMA Size	Position (see figure above)	Width W	Height H
Narrow ①	1-2	—	5.5 (140)	6.0 (152)
Standard	1-3	—	8.5 (216)	26.0 (660)
	4	—	8.5 (216)	39.0 (991)
	5	A	10.0 (254)	22.0 (559)
		B	15.0 (381)	12.0 (305)
Oversize	1-2	—	12.0 (318)	39.0 (991)
	3	—	11.0 (279)	39.0 (991)

Note

① Space is between disconnect switch or circuit breaker and starter.

A200—Fusible Disconnect

Product Description

- Three-phase magnetic
- Interchangeable heater OLR

Standard ECN54 controllers have a HAND/OFF/AUTO selector switch and START and RESET pushbuttons mounted on the enclosure and are wired as illustrated on **Page V10-T6-12**.

Type 3R enclosure does not include top conduit hubs. Hubs are available in kit form—see table on **Page V10-T6-5**.

If branch circuit protective device is 45A or greater, C320FBR1 fuse kit (panel mounted) may be required for control circuit protection per NEC 430-72.

Stainless steel enclosure may be ordered by changing the seventh digit to **A**. Type 3R rating will still apply.

Product Selection

Class EC254—Combination A200 Pump Panel—Fusible Disconnect

NEMA Size	Motor Voltage ①	Max. hp 50/60 Hz	Fuse Clip Rating ②		Narrow Width ③	Standard Width ③
			Amperes	Volts	Catalog Number	Catalog Number
1	230	7-1/2	30	250	EC25412BAB-E14	EC25412BAB
	460	10		600	EC25412CAC-E14	EC25412CAC
	—	—	Not installed	Not installed	EC25412AAA-E14	EC25412AAA
2	230	15	60	250	EC25422BAD-E14	EC25422BAD
	460	25		600	EC25422CAE-E14	EC25422CAE
	—	—	Not installed	Not installed	EC25422AAA-E14	EC25422AAA
3	230	30	100	250	—	EC25432BAF
	460	50		600	—	EC25432CAG
	—	—	Not installed	Not installed	—	EC25432AAA
4	230	50	200	250	—	EC25442BAH
	460	100		600	—	EC25442CAJ
	—	—	Not installed	Not installed	—	EC25442AAA
5	230	100	400	250	—	EC25452BAK
	460	200		600	—	EC25452CAL
6	230	200	600	250	—	EC25462BAM
	460	400		600	—	EC25462CAN
7	460	600	1200	600	—	EC25472CAQ

Notes

Starters do not include heater packs. Select 1 carton of 3 heater packs. For heater pack selection, see **Tab 15**.

① Dual element fuse ratings.

② Class R fuse clips, except for Size 7 which uses Class L fuse clips. For starters with clips “Not Installed”, select fuse clip kit on **Page V10-T6-8**.

③ To order without the START pushbutton, add modification code **P6**.

For Other Volts and Hertz Applications

For other than listed volts and hertz, select required controller by catalog number and replace the magnet coil alpha designation, eighth digit in catalog number, with proper code suffix from the table below.

Example: For 600V 60 Hz coil, change EC25412**B**AC to EC25412**D**AC.

Coil Voltage

Coil Volts and Hertz	Suffix Code
120/60 or 110/50	A
240/60 or 220/50	B
480/60 or 440/50	C
600/60 or 550/50	D
208/60	E

6.1

Pump Panels

Industrial Pump Panels

Wiring Diagram

Typical Wiring Diagram

6

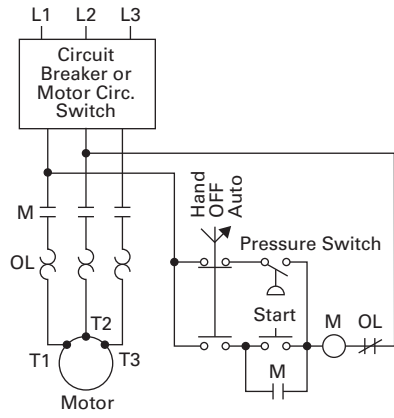

A200—Circuit Breaker

Product Description

- Three-phase magnetic
- Interchangeable heater OLR

These ECN55 pump controllers feature the A200 starters. They have a HAND/OFF/AUTO selector switch and START pushbutton mounted on the enclosure and a RESET button on the front—wiring is as illustrated in the wiring diagram on **Page V10-T6-12**.

Type 3R enclosure does not include top conduit hubs. Hubs are available in kit form—see **Page V10-T6-5**.

If branch circuit protective device is 45A or greater, C320FBR1 fuse kit (panel mounted) may be required for control circuit protection per NEC 430-72.

Stainless steel enclosure may be ordered by changing the seventh digit to **A**. Type 3R rating will still apply.

Product Selection

Class EC255—Combination A200 Pump Panel—Circuit Breaker

NEMA Size	Motor Voltage	Max. hp 50/60 Hz	Circuit Breaker Size	Narrow Width ^①	Standard Width ^②
				Catalog Number	Catalog Number
1	230	1	7A	EC25512BAC-E14	EC25512BAC
		3	15A	EC25512BAD-E14	EC25512BAD
		7-1/2	30A	EC25512BAE-E14	EC25512BAE
	460	1	3A	EC25512CAB-E14	EC25512CAB
		3	7A	EC25512CAC-E14	EC25512CAC
		5	15A	EC25512CAD-E14	EC25512CAD
2	230	10	50A	EC25522BAF-E14	EC25522BAF
		25		EC25522CAF-E14	EC25522CAF
		30	100A	—	EC25532BAG
	460	50		—	EC25532CAG
		50	150A	—	EC25542BAH
		100		—	EC25542CAH
3	230	60	250A	—	EC25552BAJ
		100	400A	—	EC25552BAK
		150	250A	—	EC25552CAJ
	460	200	400A	—	EC25552CAK
		125	600A	—	EC25562BAL
		200	800A	—	EC25562BAM
4	230	300	600A	—	EC25562CAL
		400	800A	—	EC25562CAM
	460	250	③	—	EC25572BAU
		300		—	EC25572BAU
5	230	500		—	EC25572CAU
		600		—	EC25572CAU

For Other Volts and Hertz Applications

For other than listed volts and hertz, select required controller by catalog number and replace the magnet coil alpha designation, eighth digit in catalog number with proper code suffix from the table below.

Example: For 600V 60 Hz coil, change EC25512**C**AC to EC25512**D**AC.

Coil Voltage

Coil Volts and Hertz	Suffix Code
120/60 or 110/50	A
240/60 or 220/50	B
480/60 or 440/50	C
600/60 or 550/50	D
208/60	E

Notes

Starters do not include heater packs. Select one carton of three heater packs. For heater pack selection, see **Tab 15**.

- ① To order without the START pushbutton, add modification code **P6**.
- ② Consult factory in the event ground fault protection is required.
- ③ Supply hp, voltage, FLA and whether motor is design E or not when ordering the starter.

6.1

Pump Panels

Industrial Pump Panels

Dimensions

Approximate Dimensions in Inches (mm)

Panel Space

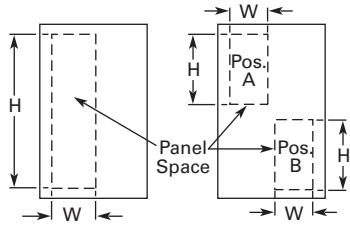

NEMA Sizes 1-4

NEMA Size 5

Panel Size	NEMA Size	Position (see figure above)	Width W	Height H
Narrow ^①	1-2	—	5.5 (140)	6.0 (152)
Standard	1-3	—	8.5 (216)	26.0 (660)
	4	—	8.5 (216)	39.0 (991)
	5	A	10.0 (254)	22.0 (559)
		B	15.0 (381)	12.0 (305)
Oversize	1-2	—	12.0 (318)	39.0 (991)
	3	—	11.0 (279)	39.0 (991)

Note

^① Space is between disconnect switch or circuit breaker and starter.

Vacuum Starter Pump Panels



Contents

<i>Description</i>	<i>Page</i>
Vacuum Starter Pump Panels	
Product Selection	V10-T6-16
Wiring Diagram	V10-T6-16

Freedom—Fusible Disconnect and Circuit Breaker

Product Description

- Three-phase magnetic
- Interchangeable heater OLR

Standard ECV54, 55 controllers have a HAND/OFF/AUTO selector switch and START pushbutton mounted on the enclosure and are wired as illustrated on **Page V10-T6-16**.

Type 3R enclosure does not include top conduit hubs. Hubs are available in kit form—see **Page V10-T6-5**.

If branch circuit protective device is 45A or greater, C320FBR1 fuse kit (panel mounted) may be required for control circuit protection per NEC 430-72.

Standards and Certifications

Note: See **Tab 17** for additional information on standards and certifications that apply to all enclosed control products.

- UL Listed
- cUL (indicates appropriate CSA Standard investigation)
- ABS Type Approved
- OSHPD Certified (OSP-0015-10)

Additional Reference

<i>Description</i>	<i>Page</i>
Kits	V10-T6-5
Dimensions	Tab 14
Accessories and Modifications	Tab 15

Product Selection

Class ECV54—Combination Vacuum Pump Panel—Fusible Disconnect

NEMA Size	Motor Voltage	Max. hp 50/60 Hz	Fuse Clip Rating Amperes	Volts	With START Pushbutton Catalog Number
4	230	50	200	250	ECV5442BAH
	460	100		600	ECV5442CAJ
5	230	100	400	250	ECV5452BAK
	460	200		600	ECV5452CAL
6	230	200	600	250	ECV5462BAM
	460	400		600	ECV5462CAN

Class ECV55—Combination Vacuum Pump Panel—Circuit Breaker

NEMA Size	Motor Voltage	Max. hp 50/60 Hz	Circuit Breaker Size	With START Pushbutton Catalog Number
4	230	50	150A	ECV5542BAH
	460	100		ECV5542CAH
5	230	75	250A	ECV5552BAJ
		100	400A	ECV5552BAK
	460	150	250A	ECV5552CAJ
		200	400A	ECV5552CAK
6	230	200	600A	ECV5562BAL
	460	400		ECV5562CAL

Note

Starters do not include heater packs. Select one carton of three heater packs. For heater pack selection, see Tab 15.

Wiring Diagram

Typical Wiring Diagram

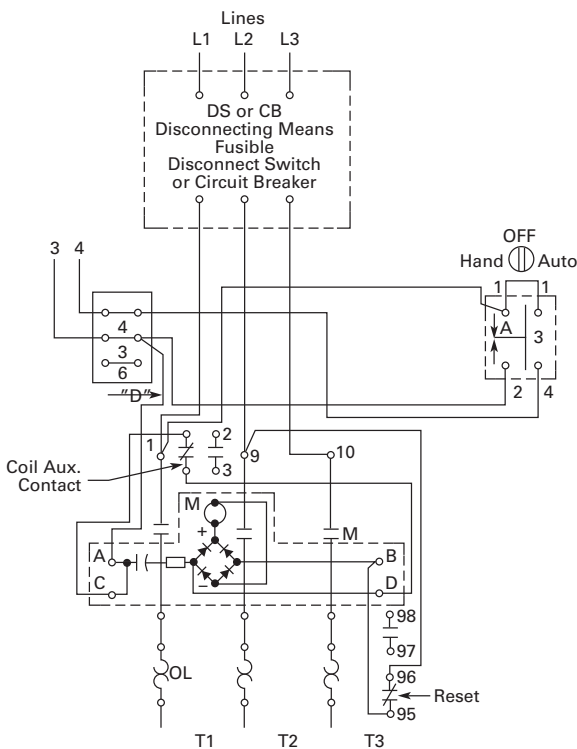

Irrigation Pump Panel—C440 SSOL



Contents

Description	Page
Irrigation Pump Panels	
Catalog Number Selection	V10-T6-18
Pump Panels—Interchangeable Heater Overload	
Product Selection	V10-T6-19
Pump Panels—Solid-State Overload	
Product Selection	V10-T6-20
Wiring Diagram	V10-T6-22

Product Description

Eaton’s irrigation pump controllers are combination starters designed to meet the requirements of the agricultural industry. The enclosure is UL Type 3R rated to provide weathertight protection and is available in two sizes. Irrigation application specific accessories and modifications are available to fit the customer’s requirements.

The irrigation pump panels use Freedom series motor starting technology to control motors up to 100 hp at 460V. These controllers have two styles of overload protection available, interchangeable heater and solid-state overload (SSOL).

Features

- The interchangeable heater overload (C306) uses individual heater packs to allow customers the ability to use various heater styles
- The solid-state overload relay (C440) provides enhanced protection and adjustment ranges as compared to bimetallic overload relays. Trip Class 10, 20, and 30 are available, along with a very wide trip current range to make setup very easy

Standards and Certifications

Note: See **Tab 17** for additional information on standards and certifications that apply to all enclosed control products.

- UL Listed
- cUL Listed (indicates appropriate CSA Standard investigation)
- ABS Type Approved
- OSHPD Certified (OSP-0015-10)

Additional Reference

Kits	V10-T6-5
Dimensions	Tab 14
Accessories and Modifications	Tab 15

6.3

Pump Panels

Irrigation Pump Panels

Catalog Number Selection

Irrigation Pump Panel

6

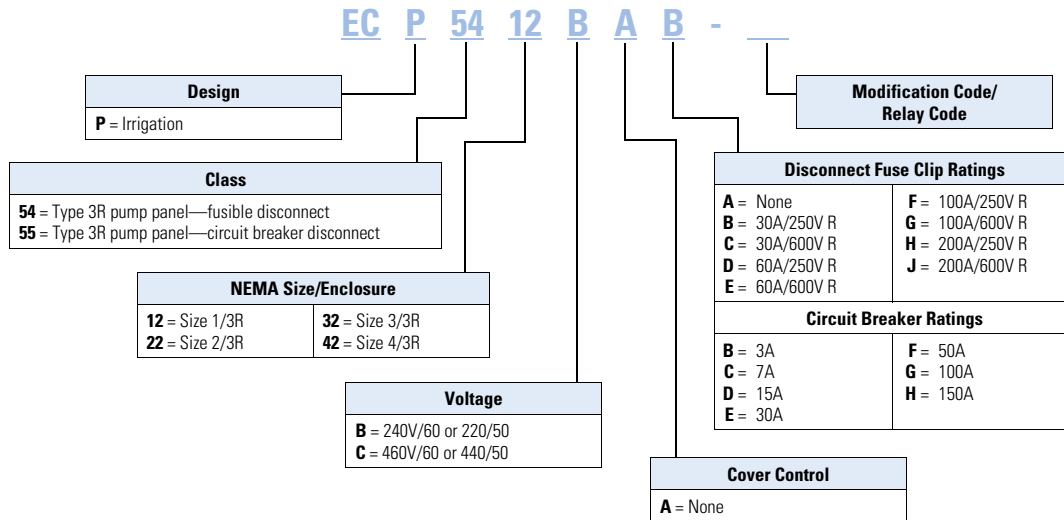

Pump Panels—Interchangeable Heater Overload

Product Selection

Standard ECP54 controllers have a HAND/OFF/AUTO selector switch and START

pushbutton mounted on the enclosure and are wired as illustrated on **Page V10-T6-22**.

Class ECP54—Combination Irrigation Pump Panel—Fusible Disconnect

NEMA Size	Motor Voltage ①	Max. hp 50/60 Hz	Fuse Clip Rating ②		Standard Width Catalog Number
			Amperes	Volts	
1 ③	230	7-1/2	30	250	ECP5412BAB
	460	10		600	ECP5412CAC
	—	—	Not installed	Not installed	ECP5412AAA
2	230	15	60	250	ECP5422BAD
	460	25		600	ECP5422CAE
	—	—	Not installed	Not installed	ECP5422AAA
3	230	30	100	250	ECP5432BAF
	460	50		600	ECP5432CAG
	—	—	Not installed	Not installed	ECP5432AAA

For Other Volts and Hertz Applications

For other than listed volts and hertz, select required controller by catalog number and replace the magnet coil alpha designation, eighth digit in catalog number with proper code suffix from the table below.

Example: For 600V 60 Hz coil, change ECP5412**B**AB to ECP5412**D**AB.

Coil Voltage

Coil Volts and Hertz	Suffix Code
120/60 or 110/50	A
240/60 or 220/50	B
480/60 or 440/50	C
600/60 or 550/50	D
208/60	E

Fuse Clips

C351—Fuse Clip Selection—Three-Pole (Three Fuses)

NEMA Size	Motor Voltage	Fuse Clip Rating Amperes	Volts	Fuse Clip Kit for Field Installation in Non-Fusible Starter	
				For Non-Rejection Type Fuses Catalog Number	For Use with "R" Rejection Type Fuses Catalog Number
1	200/230	30	250	C351KC21	C351KC21R
	460-575		600	C351KD22-61	C351KD22-61R
2	200	60	250	C351KD22-61	C351KD22-61R
	230			C351KD22-61	C351KD22-61R
	460-575			C351KD62	C351KD62R
3	200	100	250	C351KE23-63	C351KE23-63 ④
	230			C351KE23-63	C351KE23-63 ④
	460-575		600	C351KE23-63	C351KE23-63 ④

Notes

Starters do not include heater packs. Select one carton of three heater packs. For heater pack selection, see **Tab 15**.

- ① Dual element fuse ratings.
- ② Class R fuse clips.
- ③ For Compact NEMA Size 1 or Size 4 Pump Panel, add modification code **C60**. (Example: ECN5412AAA-**C60**).

Compact NEMA Size 1 and Size 4 Starters Electrical Life at Rated Continuous Current

NEMA Size	Rated Current (Amp)	
	AC3/AC4	Operations
1C	27/150	2,500,000/40,000
1	27/153	5,000,000/110,000

- ④ Fuse clip "R" rejection members for use with Class R fuses are supplied loose both in fuse clip kits and when fuse clips are factory installed.

Pump Panels—Solid-State Overload

Product Selection

Class ECP54—Combination Irrigation Pump Panel with Solid-State Overload—Fusible Disconnect ^①

Motor Voltage	NEMA Size	Maximum hp	Fuse Clip Amperes	Trip Range	Catalog Number
240V	1 ^②	1	30	1.0–5.0	ECP5412BAB-R63/B
		3		4–20	ECP5412BAB-R63/C
		7-1/2		9–45	ECP5412BAB-R63/D
	2	10	60	9–45	ECP5422BAD-R63/D
		15		ECP5422BAD-R63/D	
	3	25	100	20–100	ECP5432BAF-R63/E
480V	1 ^②	1	30	1.0–5.0	ECP5412CAC-R63/B
		2		ECP5412CAC-R63/B	
		5		4–20	ECP5412CAC-R63/C
		10		ECP5412CAC-R63/C	
	2	20	60	9–45	ECP5422CAE-R63/D
		25		ECP5422CAE-R63/D	
	3	50	100	20–100	ECP5432CAG-R63/E

Class ECP55—Combination Irrigation Pump Panel with Solid-State Overload—Circuit Breaker ^①

Motor Voltage	NEMA Size	Maximum hp	Breaker Rating	Trip Range	Catalog Number
240V	1 ^②	1	7	1.0–5.0	ECP5512BAC-R63/B
		3	15	4–20	ECP5512BAD-R63/C
		7-1/2	30	9–45	ECP5512BAE-R63/D
	2	10	50	9–45	ECP5522BAF-R63/D
		15	20–100	ECP5522BAF-R63/E	
	3	25	100	20–100	ECP5532BAG-R63/E
	4 ^②	50	28–140	ECP5532BAH-R63/F	
480V	1 ^②	1	30	1.0–5.0	ECP5512CAB-R63/B
		2		ECP5512CAC-R63/B	
		5		4–20	ECP5512CAD-R63/C
		10		ECP5512CAE-R63/C	
	2	20	60	9–45	ECP5522CAE-R63/D
		25		ECP5522CAF-R63/D	
	3	50	100	20–100	ECP5532CAG-R63/E
	4 ^②	100	150	28–140	ECP5532CAG-R63/F

Note

^① Motor FLA based on NEC Table.

^② For Compact NEMA Size 1 or Size 4 Pump Panel, add modification code **C60**. (Example: ECN5412AAA-C60).

Compact NEMA Size 1 and Size 4 Starters Electrical Life at Rated Continuous Current

NEMA Size	Rated Current (Amp) AC3/AC4	Operations
1C	27/150	2,500,000/40,000
1	27/153	5,000,000/110,000
4C	135/516	500,000/40,000
4	135/822	800,000/70,000

Class ECP55—Combination Irrigation Pump Panel—Circuit Breaker

Motor Voltage	NEMA Size	Maximum hp	Breaker Rating	Catalog Number	Motor Voltage	NEMA Size	Maximum hp	Breaker Rating	Catalog Number
240V	1 ①	1	7	ECP5512BAC	480V	1 ①	1	3	ECP5512CAB
		3	15	ECP5512BAD			3	7	ECP5512CAC
		7-1/2	30	ECP5512BAE			5	15	ECP5512CAD
	2	10	50	ECP5522BAF		2	10	30	ECP5512CAE
		15	70	ECP5522BAW			10	30	ECP5522CAE
	3	25	100	ECP5532BAG		25	50	ECP5522CAF	
	4 ①	50	150	ECP5542BAH		3	50	100	ECP5532CAG
				4 ①	100	175	ECP5542CAN		

Overload Relays

Freedom Solid-State Overload Relays

NEMA Size	Full Load Current Adjustment Range (A)	Three-Phase without Ground Fault	Three-Phase with Ground Fault
		Auto/Manual Reset Overload Selectable Class 10/20/30	Auto/Manual Reset Overload Selectable Class 10/20/30
00	0.33–1.65 ②	R63/A	R64/A
	1–5	R63/B	R64/B
	4–20	R63/C	R64/C
0 and 1	0.33–1.65 ②	R63/A	R64/A
	1–5	R63/B	R64/B
	4–20	R63/C	R64/C
	9–45	R63/D	R64/D
2	9–45	R63/D	R64/D
3	20–100	R63/E	R64/E
4	28–140	R63/F	R64/F
5	60–300 ③	R63/G	R64/G
6	120–600 ④	R63/H	R64/H

Notes

① Compact NEMA Size 1 or Size 4 Pump Panel, add modification code **C60**. (Example: ECN5412AAA-**C60**).

**Compact NEMA Size 1 and Size 4 Starters
Electrical Life at Rated Continuous Current**

NEMA Size	Rated Current (Amp)	
	AC3/AC4	Operations
1C	27/150	2,500,000/40,000
1	27/153	5,000,000/110,000
4C	135/516	500,000/40,000
4	135/822	800,000/70,000

② Not UL Listed.

③ NEMA Size 5 starter available with 60–300A panel mounted CTs. Starter as an assembled unit with 1–5A C440 overload relay (C440A1A005SELAX or C440A2A005SELAX).

④ NEMA Size 6 starter available with 120–600A panel mounted CTs. Starter as an assembled unit with 1–5A C440 overload relay (C440A1A005SELAX or C440A2A005SELAX).

Features:

- Self powered
- Phase loss protection
- Current adjustment knob
- ±1% repeat accuracy
- 1NO and 1NC isolated contacts
- Predictive indication
- Enhanced protection and monitoring
- Communication capabilities

6.3

Pump Panels

Irrigation Pump Panels

Wiring Diagram

Typical Wiring Diagram

6

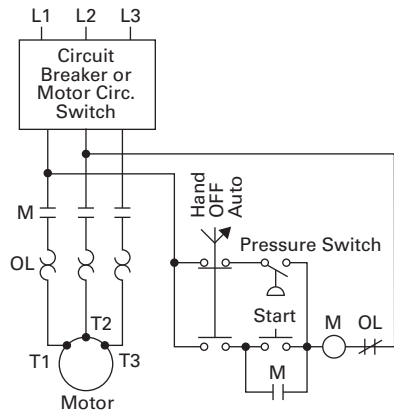

Contents

<i>Description</i>	<i>Page</i>
Duplex Pump Panels	
Catalog Number Selection	V10-T6-24
Cover Control	V10-T6-25
Non-Combination	
Features	V10-T6-26
Product Selection	V10-T6-26
Combination	
Features	V10-T6-27
Product Selection	V10-T6-27

Product Description

Eaton’s duplex pump panels are controllers with or without disconnect, and designed to meet the requirement for two alternating pumps in critical installations. All duplex pump panels are provided standard with two three-phase magnetic starters and an automatic alternator to provide equal pump wear. During periods for heavy demand, both pumps will operate.

The enclosure options include UL Type 1, 12, 3R, or 4X.

Standards and Certifications

Note: See **Tab 17** for additional information on standards and certifications that apply to all enclosed control products.

- UL Listed
- cUL Listed (indicates appropriate CSA Standard investigation)
- ABS Type Approved
- OSHPD Certified (OSP-0015-10)

Additional Reference

Other Magnet Coils	V10-T6-24
Cover Control	V10-T6-25
Dimensions	Tab 14
Accessories and Modifications	Tab 15
Technical Data and Specifications	Tab 17

Catalog Number Selection

Freedom Duplex Pump Panels

6

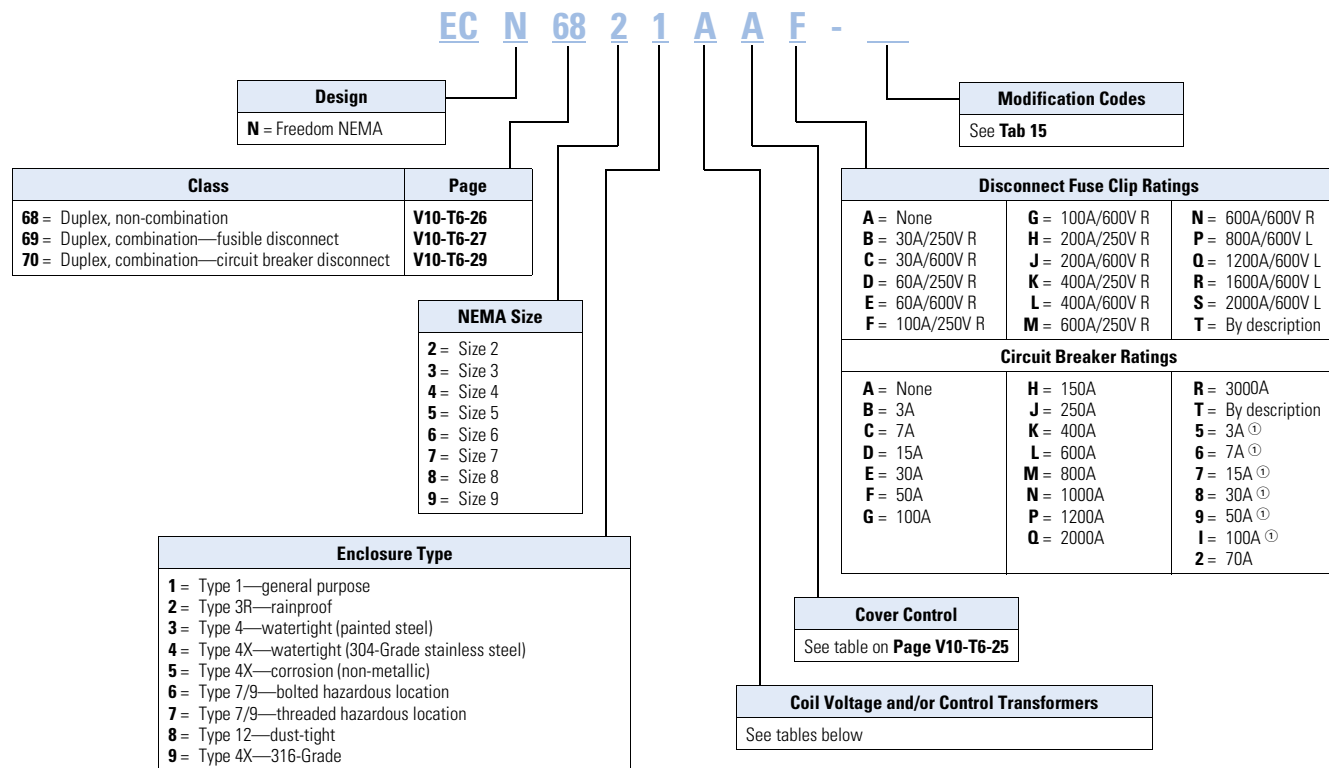

Magnetic Coil Codes (System Voltage) ②

Code	Magnet Coil	Code	Magnet Coil	Code	Magnet Coil
A	120/60110/50	K	240/50	U	24/50
B	240/60220/50	L	380/50	V	32/50
C	460/60440/50	M	415/50	W	48/60
D	575/60550/50	P	12 Vdc	X	104–120/60
E	208/60	Q	24 Vdc	Y	48/50
G	550/50	R	48 Vdc	Z	By description
H	277/60	S	125 Vdc		
J	208–240/60	T	24/60		

Control Power Transformer Codes (System Voltage)

Code	Primary	Secondary
B	240/480–220/440 wired for 240V	120/60–110/50
C	240/480–220/440 wired for 480V	120/60–110/50
D	600/60–550/50	120/60–110/50
E	208/60	120/60
H	277/60	120/60
L	380/50	110/50
M	415/50	110/50
Q	208/60	24
R	240/480–220/440 wired for 240V	24
S	240/480–220/440 wired for 480V	24
T	600/60	24
U	277/60	24
V	380/50	24
W	415/50	24
X	240/480/600 wired for 480V	120
Y	240/480/600 wired for 480V	24
Z	By description	—

Notes

- ① Use for Sizes 0–3, HMCP 600V applications only.
- ② When control power transformer modification codes (C1–C11) are used or when starter class includes CPT (that is, ECN07, 18) see table to the right for system voltage code.

Cover Control

Non-Reversing

Flange Control Kits

For on-the-job conversion of Type 1, 3R, 4X and 12 enclosed starters. Knockouts are provided on the Type 1 flange. Type 3R, 4X and 12 have prepunched holes with removable hole plugs.

Factory Installed Pilot Devices

To order factory installed pilot devices, change the 9th character of the catalog number to the alpha shown in the table below. Example: to order an **ECN0514CAA** with START/STOP pushbuttons and a red pilot light, change the **A** to a **C**, for example, **ECN0514CCA**.

Type 1 Cover Control



All Other Cover Controls



Non-Reversing Cover Control

Description	Factory Installed Flange Control			Field Installation Kits	
	Position 9 Alpha	Type 1 Non-Combination ①	All Others ②	Type 1 Non-Combination ① Catalog Number	All Others ② Catalog Number
No cover mounted pilot devices	A	■	■	C400GK0	—
START/STOP pushbuttons	B	■	■	C400GK1	C400T1
With red RUN pilot light	C	■	■	C400GK12 ③	—
With red RUN/green OFF lights	D	■	■	C400GK16 ③	—
ON/OFF pushbuttons	E	—	■	—	C400T2
With red RUN pilot light	F	—	■	—	—
With red RUN/green OFF lights	G	—	■	—	—
HAND/OFF/AUTO selector switch	H	■	■	C400GK3	C400T12
With red RUN pilot light	J	■	■	C400GK32 ③	—
With red RUN/green OFF lights	K	■	■	C400GK36 ③	—
START pushbutton	L	—	■	—	C400T3
ON pushbutton	M	—	■	—	C400T4
OFF pushbutton	N	—	■	—	C400T5
Red RUN pilot light	P	■	■	C400GK42 ③	C400T9 ③
Green OFF	Q	■	■	C400GK41 ③	C400T10 ③
Red RUN/green OFF pilot lights	R	■	■	C400GK46 ③	C400T11 ③
START/STOP selector switch	S	—	■	—	C400T13
With red RUN pilot light	T	—	■	—	—
With red RUN/green OFF lights	U	—	■	—	—
ON/OFF selector switch	V	—	■	—	C400T14
With red RUN pilot light	W	—	■	—	—
With red RUN/green OFF lights	X	—	■	—	—

Notes

- ① Type 1, NEMA Sizes 00–4 non-combination ONLY.
- ② Type 1, NEMA Sizes 5–9 non-combination PLUS all Type 3R, 4X, 12 non-combination PLUS all combination—NEMA sizes only.
- ③ Add code letter from the table below to catalog number for voltage—kits only. Example: C400T9B.

Rating	Code Letter	Rating	Code Letter	Rating	Code Letter
120V 60 Hz	A	240V 60 Hz	B	480V 60 Hz	C
208V 60 Hz	E	380V 50 Hz	L	600V 60 Hz	D

Non-Combination

Features

- Full voltage non-reversing non-combination
- Three-phase magnetic, three-pole
- Interchangeable heater OLR
- 600V maximum

Alternator

In normal operation, the alternator automatically selects alternate pumps for each succeeding cycle to equalize pump wear. During periods of heavy demand, both pumps will operate.

Product Selection

Class ECN68—Non-Combination Duplex Pump Panels with Automatic Alternator ^{①②}

NEMA Size	Motor Voltage	Max. hp Rating	Magnet Coil Voltage	Type 1 General Purpose Catalog Number	Type 3R Rainproof Catalog Number	Type 4X ^③ Watertight and Dust-Tight Stainless Steel Catalog Number	Type 12 Dust-Tight Industrial External Reset ^④ Catalog Number	Component Starter (Open) ^⑤ Catalog Number
0	—	—	120	ECN6801AAA	ECN6802AAA	ECN6804AAA	ECN6808AAA	AN16BN0AC
	200	3	208	ECN6801EAA	ECN6802EAA	ECN6804EAA	ECN6808EAA	AN16BN0EC
	230		240	ECN6801BAA	ECN6802BAA	ECN6804BAA	ECN6808BAA	AN16BN0BC
	460	5	480	ECN6801CAA	ECN6802CAA	ECN6804CAA	ECN6808CAA	AN16BN0CC
	575		600	ECN6801DAA	ECN6802DAA	ECN6804DAA	ECN6808DAA	AN16BN0DC
1	—	—	120	ECN6811AAA	ECN6812AAA	ECN6814AAA	ECN6818AAA	AN16DN0AB
	200	7-1/2	208	ECN6811EAA	ECN6812EAA	ECN6814EAA	ECN6818EAA	AN16DN0EB
	230		240	ECN6811BAA	ECN6812BAA	ECN6814BAA	ECN6818BAA	AN16DN0BB
	460	10	480	ECN6811CAA	ECN6812CAA	ECN6814CAA	ECN6818CAA	AN16DN0CB
	575		600	ECN6811DAA	ECN6812DAA	ECN6814DAA	ECN6818DAA	AN16DN0DB
2	—	—	120	ECN6821AAA	ECN6822AAA	ECN6824AAA	ECN6828AAA	AN16GN0AB
	200	10	208	ECN6821EAA	ECN6822EAA	ECN6824EAA	ECN6828EAA	AN16GN0EB
	230	15	240	ECN6821BAA	ECN6822BAA	ECN6824BAA	ECN6828BAA	AN16GN0BB
	460	25	480	ECN6821CAA	ECN6822CAA	ECN6824CAA	ECN6828CAA	AN16GN0CB
	575		600	ECN6821DAA	ECN6822DAA	ECN6824DAA	ECN6828DAA	AN16GN0DB
3	—	—	120	ECN6831AAA	ECN6832AAA	ECN6834AAA	ECN6838AAA	AN16KN0A
	200	25	208	ECN6831EAA	ECN6832EAA	ECN6834EAA	ECN6838EAA	AN16KN0E
	230	30	240	ECN6831BAA	ECN6832BAA	ECN6834BAA	ECN6838BAA	AN16KN0B
	460	50	480	ECN6831CAA	ECN6832CAA	ECN6834CAA	ECN6838CAA	AN16KN0C
	575		600	ECN6831DAA	ECN6832DAA	ECN6834DAA	ECN6838DAA	AN16KN0D
4	—	—	120	ECN6841AAA	ECN6842AAA	ECN6844AAA	ECN6848AAA	AN16NN0A
	200	40	208	ECN6841EAA	ECN6842EAA	ECN6844EAA	ECN6848EAA	AN16NN0E
	230	50	240	ECN6841BAA	ECN6842BAA	ECN6844BAA	ECN6848BAA	AN16NN0B
	460	100	480	ECN6841CAA	ECN6842CAA	ECN6844CAA	ECN6848CAA	AN16NN0C
	575		600	ECN6841DAA	ECN6842DAA	ECN6844DAA	ECN6848DAA	AN16NN0D

Notes

Starters do not include heater packs. Select two cartons of three heater packs (two overload relays—one for each motor). For heater pack selection, see **Tab 15**.

① Circuitry arranged for two-pole pilot devices.

② All duplexes come standard with alternator. To remove, add modification code **D12**.

③ The catalog numbers listed in the Type 4X column are for Type 4X 304-Grade stainless steel, as indicated by the **seventh** digit. Example: ECN6804AAA. To order Type 4X 316-Grade stainless steel, change that digit to **9**. To order Type 4 painted steel, change that digit to **3**. To order non-metallic, change that digit to **5**. For details on these alternate enclosures, see **Tab 13**.

④ All Type 12 enclosures are standardized with external reset. For internal reset, order modification code **R5**.

⑤ Requires two starters.

Combination

Features

- Full voltage non-reversing combination
- Three-phase magnetic, three-pole
- Interchangeable heater OLR
- 600V maximum

Alternator

In normal operation, the alternator automatically selects alternate pumps for each succeeding cycle to equalize pump wear. During periods of heavy demand, both pumps will operate.

Product Selection

Class ECN69—Combination Duplex Pump Panels with Automatic Alternator—Fusible Disconnect ^{①②}

NEMA Size	Motor Voltage	Max. hp Rating Dual Element Fuses	Magnet Coil Voltage ③	Fuse Clip Amps.	Type 1 General Purpose Catalog Number	Type 3R Rainproof Catalog Number	Type 4X ④ Watertight and Dust-Tight Stainless Steel Catalog Number	Type 12 Dust-Tight Industrial External Reset ⑤⑥	Component Starter (Open) ⑦ Catalog Number
0	230	3	120	30A	ECN6901AAB	ECN6902AAB	ECN6904AAB	ECN6908AAB	AN16BN0AC
	460	5			ECN6901AAC	ECN6902AAC	ECN6904AAC	ECN6908AAC	AN16BN0AC
	200	3	208		ECN6901EAB	ECN6902EAB	ECN6904EAB	ECN6908EAB	AN16BN0EC
	230		240		ECN6901BAB	ECN6902BAB	ECN6904BAB	ECN6908BAB	AN16BN0BC
	460	5	480		ECN6901CAC	ECN6902CAC	ECN6904CAC	ECN6908CAC	AN16BN0CC
	575		600		ECN6901DAC	ECN6902DAC	ECN6904DAC	ECN6908DAC	AN16BN0DC
1	230	7-1/2	120	30A	ECN6911AAB	ECN6912AAB	ECN6914AAB	ECN6918AAB	AN16DN0AB
	460	10			ECN6911AAC	ECN6912AAC	ECN6914AAC	ECN6918AAC	AN16DN0AB
	200	7-1/2	208		ECN6911EAB	ECN6912EAB	ECN6914EAB	ECN6918EAB	AN16DN0EB
	230		240		ECN6911BAB	ECN6912BAB	ECN6914BAB	ECN6918BAB	AN16DN0BB
	460	10	480		ECN6911CAC	ECN6912CAC	ECN6914CAC	ECN6918CAC	AN16DN0CB
	575		600		ECN6911DAC	ECN6912DAC	ECN6914DAC	ECN6918DAC	AN16DN0DB
2	230	15	120	60A	ECN6921AAD	ECN6922AAD	ECN6924AAD	ECN6928AAD	AN16GN0AB
	460	25			ECN6921AAE	ECN6922AAE	ECN6924AAE	ECN6928AAE	AN16GN0AB
	200	10	208		ECN6921EAD	ECN6922EAD	ECN6924EAD	ECN6928EAD	AN16GN0EB
	230	15	240		ECN6921BAD	ECN6922BAD	ECN6924BAD	ECN6928BAD	AN16GN0BB
	460	25	480		ECN6921CAE	ECN6922CAE	ECN6924CAE	ECN6928CAE	AN16GN0CB
	575		600		ECN6921DAE	ECN6922DAE	ECN6924DAE	ECN6928DAE	AN16GN0DB
3	230	30	120	100A	ECN6931AAF	ECN6932AAF	ECN6934AAF	ECN6938AAF	AN16KN0A
	460	50			ECN6931AAG	ECN6932AAG	ECN6934AAG	ECN6938AAG	AN16KN0A
	200	25	208		ECN6931EAF	ECN6932EAF	ECN6934EAF	ECN6938EAF	AN16KN0E
	230	30	240		ECN6931BAF	ECN6932BAF	ECN6934BAF	ECN6938BAF	AN16KN0B
	460	50	480		ECN6931CAG	ECN6932CAG	ECN6934CAG	ECN6938CAG	AN16KN0C
	575		600		ECN6931DAG	ECN6932DAG	ECN6934DAG	ECN6938DAG	AN16KN0D
4	230	50	120	200A	ECN6941AAH	ECN6942AAH	ECN6944AAH	ECN6948AAH	AN16NN0A
	460	100			ECN6941AAJ	ECN6942AAJ	ECN6944AAJ	ECN6948AAJ	AN16NN0A
	200	40	208		ECN6941EAH	ECN6942EAH	ECN6944EAH	ECN6948EAH	AN16NN0E
	230	50	240		ECN6941BAH	ECN6942BAH	ECN6944BAH	ECN6948BAH	AN16NN0B
	460	100	480		ECN6941CAJ	ECN6942CAJ	ECN6944CAJ	ECN6948CAJ	AN16NN0C
	575		600		ECN6941DAJ	ECN6942DAJ	ECN6944DAJ	ECN6948DAJ	AN16NN0D

Notes

Starters do not include heater packs. Select two cartons of three heater packs (two overload relays—one for each motor). For heater pack selection, see **Tab 15**.

- ① Circuitry arranged for two-pole pilot devices.
- ② All duplexes come standard with alternator. To remove, add modification code **D12**.
- ③ For 200V and 575V motors—starters with 120V coil (for separate control) are available. To order, substitute the letter **A** for the eighth character of the listed catalog number.
- ④ The catalog numbers listed in the Type 4X column are for Type 4X 304-Grade stainless steel, as indicated by the **seventh** digit. Example: ECN690**4**AAB. To order Type 4X 316-Grade stainless steel, change that digit to **9**. To order Type 4 painted steel, change that digit to **3**. To order non-metallic, change that digit to **5**. For details on these alternate enclosures, see **Tab 13**.
- ⑤ All Type 12 enclosures are standardized with external reset. For internal reset, order modification code **R5**.
- ⑥ Type 12 enclosure is without safety door interlock.
- ⑦ Requires two starters.

Class ECN69—Combination Duplex Pump Panels with Automatic Alternator—Non-Fusible Disconnect ^{①②}

NEMA Size	Motor Voltage	Max. hp Rating Dual Element Fuses	Magnet Coil Voltage	Disconnect Amps.	Type 1 General Purpose Catalog Number	Type 3R Rainproof Catalog Number	Type 4X ^③ Watertight and Dust-Tight Stainless Steel Catalog Number	Type 12 Dust-Tight Industrial External Reset ^{④⑤} Catalog Number	Component Starter (Open) ^⑥ Catalog Number
0	—	—	120	30A	ECN6901AAA	ECN6902AAA	ECN6904AAA	ECN6908AAA	AN16BN0AC
	200	3	208		ECN6901EAA	ECN6902EAA	ECN6904EAA	ECN6908EAA	AN16BN0EC
	230		240		ECN6901BAA	ECN6902BAA	ECN6904BAA	ECN6908BAA	AN16BN0BC
	460	5	480		ECN6901CAA	ECN6902CAA	ECN6904CAA	ECN6908CAA	AN16BN0CC
	575		600		ECN6901DAA	ECN6902DAA	ECN6904DAA	ECN6908DAA	AN16BN0DC
1	—	—	120	30A	ECN6911AAA	ECN6912AAA	ECN6914AAA	ECN6918AAA	AN16DN0AB
	200	7-1/2	208		ECN6911EAA	ECN6912EAA	ECN6914EAA	ECN6918EAA	AN16DN0EB
	230		240		ECN6911BAA	ECN6912BAA	ECN6914BAA	ECN6918BAA	AN16DN0BB
	460	10	480		ECN6911CAA	ECN6912CAA	ECN6914CAA	ECN6918CAA	AN16DN0CB
	575		600		ECN6911DAA	ECN6912DAA	ECN6914DAA	ECN6918DAA	AN16DN0DB
2	—	—	120	60A	ECN6921AAA	ECN6922AAA	ECN6924AAA	ECN6928AAA	AN16GN0AB
	200	10	208		ECN6921EAA	ECN6922EAA	ECN6924EAA	ECN6928EAA	AN16GN0EB
	230	15	240		ECN6921BAA	ECN6922BAA	ECN6924BAA	ECN6928BAA	AN16GN0BB
	460	25	480		ECN6921CAA	ECN6922CAA	ECN6924CAA	ECN6928CAA	AN16GN0CB
	575		600		ECN6921DAA	ECN6922DAA	ECN6924DAA	ECN6928DAA	AN16GN0DB
3	—	—	120	100A	ECN6931AAA	ECN6932AAA	ECN6934AAA	ECN6938AAA	AN16KN0A
	200	25	208		ECN6931EAA	ECN6932EAA	ECN6934EAA	ECN6938EAA	AN16KN0E
	230	30	240		ECN6931BAA	ECN6932BAA	ECN6934BAA	ECN6938BAA	AN16KN0B
	460	50	480		ECN6931CAA	ECN6932CAA	ECN6934CAA	ECN6938CAA	AN16KN0C
	575		600		ECN6931DAA	ECN6932DAA	ECN6934DAA	ECN6938DAA	AN16KN0D
4	—	—	120	200A	ECN6941AAA	ECN6942AAA	ECN6944AAA	ECN6948AAA	AN16NN0A
	200	40	208		ECN6941EAA	ECN6942EAA	ECN6944EAA	ECN6948EAA	AN16NN0E
	230	50	240		ECN6941BAA	ECN6942BAA	ECN6944BAA	ECN6948BAA	AN16NN0B
	460	100	480		ECN6941CAA	ECN6942CAA	ECN6944CAA	ECN6948CAA	AN16NN0C
	575		600		ECN6941DAA	ECN6942DAA	ECN6944DAA	ECN6948DAA	AN16NN0D

Notes

Starters do not include heater packs. Select two cartons of three heater packs (two overload relays—one for each motor). For heater pack selection, see **Tab 15**.

- ① Circuitry arranged for two-pole pilot devices.
- ② All duplexes come standard with alternator. To remove, add modification code **D12**.
- ③ The catalog numbers listed in the Type 4X column are for Type 4X 304-Grade stainless steel, as indicated by the **seventh** digit. Example: ECN6904AAA. To order Type 4X 316-Grade stainless steel, change that digit to **9**. To order Type 4 painted steel, change that digit to **3**. To order non-metallic, change that digit to **5**. For details on these alternate enclosures, see **Tab 13**.
- ④ All Type 12 enclosures are standardized with external reset. For internal reset, order modification code **R5**.
- ⑤ Type 12 enclosure is without safety door interlock.
- ⑥ Requires two starters.

Class ECN70—Combination Duplex Pump Panels with Automatic Alternator—Circuit Breaker ^{①②}

NEMA Size	Motor Voltage	Max. hp Rating	Magnet Coil Voltage ^③	Circuit Breaker Size	Type 1 General Purpose Catalog Number	Type 3R Rainproof Catalog Number	Type 4X ^④ Watertight and Dust-Tight Stainless Steel Catalog Number	Type 12 Dust-Tight Industrial External Reset ^{⑤⑥} Catalog Number	Component Starter (Open) ^⑦ Catalog Number	
0	200	1	208	7A	ECN7001EAC	ECN7002EAC	ECN7004EAC	ECN7008EAC	AN16BN0EC	
		3		15A	ECN7001EAD	ECN7002EAD	ECN7004EAD	ECN7008EAD		
	230	1	240	7A	ECN7001BAC	ECN7002BAC	ECN7004BAC	ECN7008BAC	AN16BN0BC	
		3		15A	ECN7001BAD	ECN7002BAD	ECN7004BAD	ECN7008BAD		
	460	3/4	480	3A	ECN7001CAB	ECN7002CAB	ECN7004CAB	ECN7008CAB	AN16BN0CC	
		2		7A	ECN7001CAC	ECN7002CAC	ECN7004CAC	ECN7008CAC		
		5		15A	ECN7001CAD	ECN7002CAD	ECN7004CAD	ECN7008CAD		
	575	1	600	3A	ECN7001DAB	ECN7002DAB	ECN7004DAB	ECN7008DAB	AN16BN0DC	
		3		7A	ECN7001DAC	ECN7002DAC	ECN7004DAC	ECN7008DAC		
				15A	ECN7001DAD	ECN7002DAD	ECN7004DAD	ECN7008DAD		
	1	200	1	208	7A	ECN7011EAC	ECN7012EAC	ECN7014EAC	ECN7018EAC	AN16DN0EB
			2		15A	ECN7011EAD	ECN7012EAD	ECN7014EAD	ECN7018EAD	
7-1/2			30A		ECN7011EAE	ECN7012EAE	ECN7014EAE	ECN7018EAE		
230		1	240	7A	ECN7011BAC	ECN7012BAC	ECN7014BAC	ECN7018BAC	AN16DN0BB	
		2		15A	ECN7011BAD	ECN7012BAD	ECN7014BAD	ECN7018BAD		
		7-1/2		30A	ECN7011BAE	ECN7012BAE	ECN7014BAE	ECN7018BAE		
460		3/4	480	3A	ECN7011CAB	ECN7012CAB	ECN7014CAB	ECN7018CAB	AN16DN0CB	
		2		7A	ECN7011CAC	ECN7012CAC	ECN7014CAC	ECN7018CAC		
		5		15A	ECN7011CAD	ECN7012CAD	ECN7014CAD	ECN7018CAD		
		10		30A	ECN7011CAE	ECN7012CAE	ECN7014CAE	ECN7018CAE		
575		1	600	3A	ECN7011DAB	ECN7012DAB	ECN7014DAB	ECN7018DAB	AN16DN0DB	
		3		7A	ECN7011DAC	ECN7012DAC	ECN7014DAC	ECN7018DAC		
		7-1/2		15A	ECN7011DAD	ECN7012DAD	ECN7014DAD	ECN7018DAD		
		10		30A	ECN7011DAE	ECN7012DAE	ECN7014DAE	ECN7018DAE		
2		200	10	208	50A	ECN7021EAF	ECN7022EAF	ECN7024EAF	ECN7028EAF	AN16GN0EB
		230	15		240	ECN7021BAF	ECN7022BAF	ECN7024BAF	ECN7028BAF	AN16GN0BB
		460	25		480	ECN7021CAF	ECN7022CAF	ECN7024CAF	ECN7028CAF	AN16GN0CB
		575			600	ECN7021DAF	ECN7022DAF	ECN7024DAF	ECN7028DAF	AN16GN0DB
3	200	25	208	100A	ECN7031EAG	ECN7032EAG	ECN7034EAG	ECN7038EAG	AN16KN0E	
	230	30		240	ECN7031BAG	ECN7032BAG	ECN7034BAG	ECN7038BAG	AN16KN0B	
	460	50		480	ECN7031CAG	ECN7032CAG	ECN7034CAG	ECN7038CAG	AN16KN0C	
	575			600	ECN7031DAI	ECN7032DAI	ECN7034DAI	ECN7038DAI	AN16KN0D	
4	200	40	208	150A	ECN7041EAH	ECN7042EAH	ECN7044EAH	ECN7048EAH	AN16NN0E	
	230	50		240	ECN7041BAH	ECN7042BAH	ECN7044BAH	ECN7048BAH	AN16NN0B	
	460	100		480	ECN7041CAH	ECN7042CAH	ECN7044CAH	ECN7048CAH	AN16NN0C	
	575			600	ECN7041DAH	ECN7042DAH	ECN7044DAH	ECN7048DAH	AN16NN0D	

Notes

Starters do not include heater packs. Select two cartons of three heater packs (two overload relays—one for each motor). For heater pack selection, see **Tab 15**.

- ① Circuitry arranged for two-pole pilot devices.
- ② All duplexes come standard with alternator. To remove, add modification code **D12**.
- ③ For 200V and 575V motors—starters with 120V coil (for separate control) are available. To order, substitute the letter **A** for the eighth character of the listed catalog number.
- ④ The catalog numbers listed in the Type 4X column are for Type 4X 304-Grade stainless steel, as indicated by the **seventh** digit.
Example: ECN7004EAC. To order Type 4X 316-Grade stainless steel, change that digit to **9**. To order Type 4 painted steel, change that digit to **3**. To order non-metallic, change that digit to **5**. For details on these alternate enclosures, see **Tab 13**.
- ⑤ All Type 12 enclosures are standardized with external reset. For internal reset, order modification code **R5**.
- ⑥ Type 12 enclosure is without safety door interlock.
- ⑦ Requires two starters.

Type 3R Industrial Pump Panel—
C440 SSOL



Narrow Enclosure Pump Panel



Irrigation Pump Panel—C440 SSOL



A200 Pump Panel



6.1 Industrial Pump Panels

Product Overview	V10-T6-2
Freedom—Fusible Disconnect	V10-T6-7
Freedom—Circuit Breaker	V10-T6-9
A200—Fusible Disconnect	V10-T6-11
A200—Circuit Breaker	V10-T6-13

6.2 Vacuum Starter Pump Panels

Freedom—Fusible Disconnect and Circuit Breaker	
Product Description	V10-T6-15
Standards and Certifications	V10-T6-15
Additional Reference	V10-T6-15
Product Selection	V10-T6-16
Wiring Diagram	V10-T6-16

6.3 Irrigation Pump Panels

Product Description	V10-T6-17
Features	V10-T6-17
Standards and Certifications	V10-T6-17
Additional Reference	V10-T6-17
Catalog Number Selection	V10-T6-18
Pump Panels—Interchangeable Heater Overload	V10-T6-19
Pump Panels—Solid-State Overload	V10-T6-20

6.4 Duplex Pump Panels

Product Description	V10-T6-23
Standards and Certifications	V10-T6-23
Additional Reference	V10-T6-23
Catalog Number Selection	V10-T6-24
Cover Control	V10-T6-25
Non-Combination	V10-T6-26
Combination	V10-T6-27

Industrial Pump Panels



6

Product Overview

Product Description

Eaton's pump controllers are combination starters with accessories and modifications designed to meet the particular requirements of the irrigation, oil well, gas and other pump application industries. The enclosure is Type 3R to provide weather-tight protection and is available in several sizes, depending on the customer's control option requirements. The disconnect, contactor and overload relay are the same as used in Freedom lines of combination starters. These controllers are available in standard full voltage as well as reduced voltage configurations, with vacuum contactors as well as the standard electromechanical contactors.

Eaton's revolutionary design for soft starters is shown in the S801+ and S811+ soft starter products which are members of the Intelligent Technologies (*IT.*) family of products. These reduced voltage soft starters are the most compact, multi-functional, easy-to-install products on the market. Their superiority begins with the control package, which features 24 Vdc control, onboard Digital Signal Processor (DSP), and use of a low impedance run contactor, all of which contribute to the *IT.* soft starter's safety, advanced functionality and compact size.

Contents

Description

	<i>Page</i>
Industrial Pump Panels	
Standards and Certifications	V10-T6-3
Additional Reference	V10-T6-3
Catalog Number Selection	V10-T6-4
Accessories	V10-T6-5
Freedom—Fusible Disconnect	V10-T6-7
Freedom—Circuit Breaker	V10-T6-9
A200—Fusible Disconnect	V10-T6-11
A200—Circuit Breaker	V10-T6-13

Features

The Freedom series starters are available in either fusible or circuit breaker types utilizing Type 3R rainproof and sleet resistant enclosures. Convenient straight-through wiring with top line connections and bottom load connections features easily accessible pressure connections for line, load and control. Starter and disconnect are factory wired.

- Motor Circuit Switch—** Long life, heavy-duty, quick acting, double break action. Positive ON and positive OFF available in either fusible or non-fusible versions. Fuse clip kits are available for field installation and can be converted in the field for maximum job flexibility
- Motor Circuit Protector—** Similar to a magnetic trip only circuit breaker. Features an adjustable magnetic trip characteristic for accurate, dependable fault protection and simultaneous trip of all poles to prevent single phasing
- Overload Relay—**Freedom overload relays with trip indication feature bimetallic type operation with ambient compensation and a choice of either manual or automatic reset
C440 electronic overload relays are available up to 100A as a self-powered, self-contained unit. With external CTs, C440 can protect motor up to 1500 FLA. Available add-on accessories include remote reset capability and communication modules with I/O for DeviceNet, PROFIBUS, and Modbus.
- HAND/OFF/AUTO Selector Switch and START Pushbutton—** 10250T heavy-duty units mounted on the flange of the enclosure for outside accessibility
- RESET Button—** Accessible from front of enclosure (booted for environmental protection) for operation of overload relay reset function

- **Enclosure**—Type 3R rainproof and sleet resistant construction with stainless steel door latches and special corrosion resistant paint. Enclosure features include grounding lugs, padlocking feature on door latch, drip hood over door and provisions for top mounting conduit hubs. Most enclosures include generous panel space for mounting optional control and accessories
- **Mounting**—Pole mounting feet with keyhole slots for easy mounting are standard on enclosures for Sizes 1–5 (removable for Sizes 1–5 standard width flange type enclosures). Brackets can be formed to the contour of the pole after mounting
- **Padlocking**—Provision on door latch for locking door closed, as well as provision for padlocking disconnect switch in OFF position. With a simple modification, disconnect can also be padlocked in ON position
- **UL Listed**—Underwriters Laboratories Inc. includes the “Suitable for Use as Service Equipment” label

Interrupting Ratings

- **Fusible**—Sizes 1–5 suitable for use on a circuit capable of delivering not more than 100,000 rms symmetrical amperes. 600V maximum where a Class R fuse clip kit is properly installed and Class R fuses are used. If Class R fuses are not used, the switch should not be installed on circuits capable of delivering more than 10,000 rms symmetrical amperes. Size 6 is limited to 18,000 and Size 7 is limited to 30,000 rms symmetrical amperes
- **Circuit Breaker**—Sizes 1–3 controllers are suitable for use on circuits capable of delivering not more than 100,000 rms symmetrical amperes at 480V maximum; for 600V applications not more than 65,000 rms symmetrical amperes
- **ECP Irrigation Pump Panel**—Suitable for use on circuits capable of delivering not more than 10,000 rms symmetrical amperes at 480V maximum

Optional Features

- **Backspin Timer**—0.2 seconds to 3 minutes. Prevents restart until motor and pump have stopped
- **Program Timer**—24 hour, 7 day with day omission
- **Control Transformer**—Available as standard, either as a field kit or factory installed. Includes two primary and one secondary fuses
- **Electrical Interlocks**—Side mounted in NO, NC and NO-NC. Maximum of two contacts on either side of starter through Size 2, maximum of three per side Sizes 3–5
- **Control Circuit Fuse Kit**—30A, 600V rating
- **Lightning Arrestor**—Offers protection to control from lightning induced surges
- **“R” Fuse Clip Kits**—30–200A, 250V and 600V ratings
- **Disconnect Control Circuit Interlock**—To disconnect separate control circuits

- **Enclosure Conduit Hubs**—Hole provided in enclosure top covered with hole closer. Will accept 3/4 in, 1-1/4 in, 1-1/2 in, 2 in, 2-1/2 in, and three inch conduit sizes
- **Pad Mounting Feet**—For standard width enclosures Sizes 1–5
- **Electronic Overload (SSOL)**
- **304-Grade Stainless Steel Enclosure**—For additional corrosion resistance, any of the pump panels can be ordered as 304-Grade stainless steel, still keeping the Type 3R rating
- **Soft Starter Pump Control Options**
 - Designed to reduce “water-hammer” during start-up and stopping sequences
 - Stop ramp extended to 60 seconds to help control larger motors and systems with long piping runs

Standards and Certifications

Note: See **Tab 17** for additional information on standards and certifications that apply to all enclosed control products.

- UL Listed
- cUL Listed (indicates appropriate CSA Standard investigation)
- ABS Type Approved
- OSHPD Certified (OSP-0015-10)

Additional Reference

Kits	V10-T6-5
Dimensions	Tab 14
Accessories and Modifications	Tab 15
Technical Data and Specifications	Tab 17

6.1

Pump Panels

Industrial Pump Panels

Catalog Number Selection

Pump Panel

6

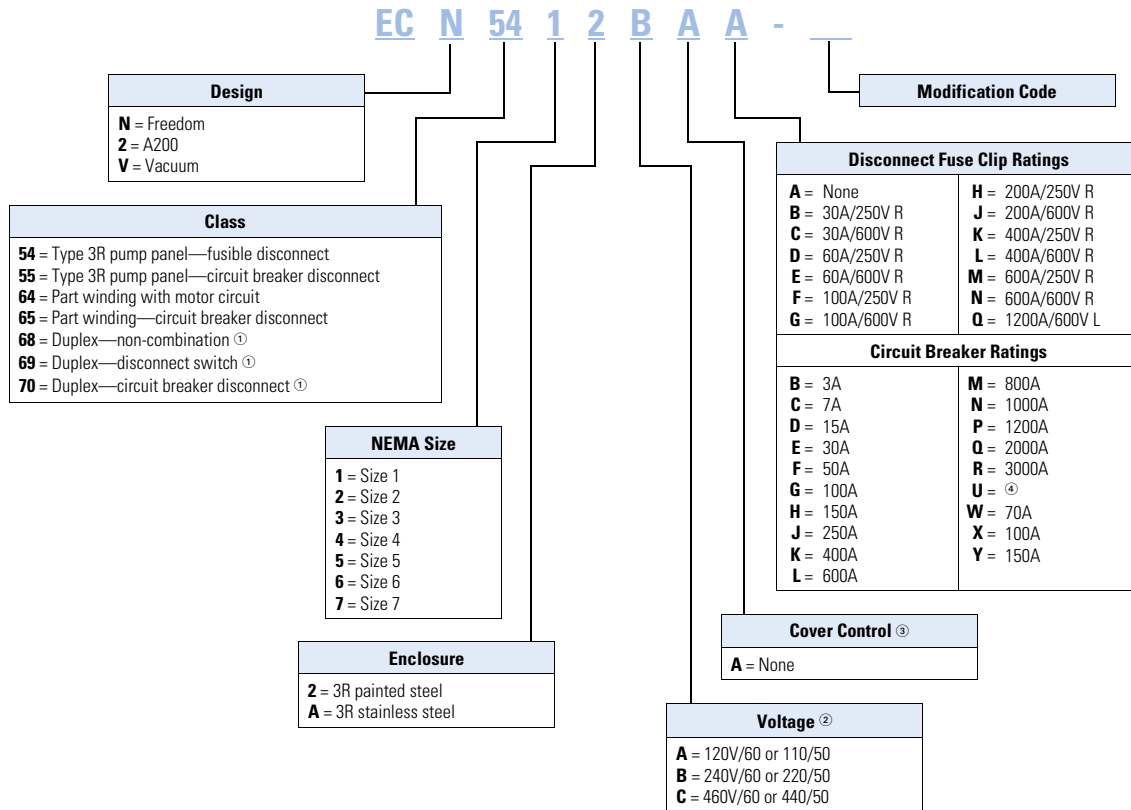

Notes

- ① More information on Type 1, 3R, 4X and 12 duplex pump panels is on **Page V10-T6-23**. Product Selection is on **Page V10-T6-26**.
- ② For other voltages and single-phase applications, consult your Eaton representative.
- ③ HOA selector switch and START pushbutton provided as standard.
- ④ Engineering determination depending on size, horsepower FLA, NEC or other considerations.

Accessories

Kits

Kits for Field Mounting

Description	Catalog Number Suffix	Catalog Number
Backspin timer—0.2 sec. to 3 min. (60 Hz)	B12	—
Control transformers 240/480V primary, 120V secondary		
Size 1	C1	—
Size 2	C1	—
Size 3	C1	—
Size 4	C1	—
Size 5	C1	—
Lightning arrestor	L3	—
Control circuit fuse kit (600V)	C31	—
Electrical interlocks—Freedom line/vacuum		
NO	A27	—
NC	A28	C320KGS2
NO and NC	A29	C320KGS3
Time delay relay—3 minutes		
ON delay (unwired)	T6	—
OFF delay (unwired)	T7	—
24-hour programming clock	P44	—
Interchangeable hubs for enclosure. ^①		
Enclosure has removable top plate. If conduit hub is required, order:		
3/4 in conduit size	—	DS075H1
1-1/4 in conduit size	—	DS125H1
1-1/2 in conduit size	—	DS150H1
2 in conduit size	—	DS200H1
2-1/2 in conduit size	—	DS250H2
3 in conduit size	—	DS300H2
Power supply	C34	—

Note

^① Does not apply to reduced voltage controllers.

Overload Relays**Freedom Solid-State Overload Relays**

NEMA Size	Full Load Current Adjustment Range (A)	Three-Phase without Ground Fault Auto/Manual Reset Overload Selectable Class 10/20/30	Three-Phase with Ground Fault Auto/Manual Reset Overload Selectable Class 10/20/30
00	0.33–1.65 ^①	R63/A	R64/A
	1–5	R63/B	R64/B
	4–20	R63/C	R64/C
0 and 1	0.33–1.65 ^①	R63/A	R64/A
	1–5	R63/B	R64/B
	4–20	R63/C	R64/C
	9–45	R63/D	R64/D
2	9–45	R63/D	R64/D
3	20–100	R63/E	R64/E
4	28–140	R63/F	R64/F
5	60–300 ^②	R63/G	R64/G
6	120–600 ^③	R63/H	R64/H

Notes

- ① Not UL Listed.
- ② NEMA Size 5 starter available with 60–300A panel mounted CTs. Starter as an assembled unit with 1–5A C440 overload relay (C440A1A005SELAX or C440A2A005SELAX).
- ③ NEMA Size 6 starter available with 120–600A panel mounted CTs. Starter as an assembled unit with 1–5A C440 overload relay (C440A1A005SELAX or C440A2A005SELAX).

Freedom—Fusible Disconnect

Product Description

- Three-phase magnetic
- Interchangeable heater OLR

Standard ECN54 controllers have a HAND/OFF/AUTO selector switch and START and RESET pushbuttons mounted on the enclosure and are wired as illustrated on **Page V10-T6-8**.

Type 3R enclosure does not include top conduit hubs. Hubs are available in kit form—see **Page V10-T6-5**.

If branch circuit protective device is 45A or greater, C320FBR1 fuse kit (panel mounted) may be required for control circuit protection per NEC 430-72.

Stainless steel enclosure may be ordered by changing the seventh digit to **A**. Type 3R rating will still apply.

Product Selection

Class ECN54—Combination Pump Panel—Fusible Disconnect

NEMA Size	Motor Voltage ①	Max. hp 50/60 Hz	Fuse Clip Rating ②		Narrow Width ③	Standard Width ③
			Amperes	Volts	Catalog Number	Catalog Number
1 ④	230	7-1/2	30	250	ECN5412BAB-E14	ECN5412BAB
	460	10		600	ECN5412CAC-E14	ECN5412CAC
	—	—	Not installed	Not installed	ECN5412AAA-E14	ECN5412AAA
2	230	15	60	250	ECN5422BAD-E14	ECN5422BAD
	460	25		600	ECN5422CAE-E14	ECN5422CAE
	—	—	Not installed	Not installed	ECN5422AAA-E14	ECN5422AAA
3	230	30	100	250	—	ECN5432BAF
	460	50		600	—	ECN5432CAG
	—	—	Not installed	Not installed	—	ECN5432AAA
4 ④	230	50	200	250	—	ECN5442BAH
	460	100		600	—	ECN5442CAJ
	—	—	Not installed	Not installed	—	ECN5442AAA
5	230	100	400	250	—	ECN5452BAK
	460	200		600	—	ECN5452CAL
6	230	200	600	250	—	ECN5462BAM
	460	400		600	—	ECN5462CAN
7	460	600	1200	600	—	ECN5472CAQ

Notes

Starters do not include heater packs. Select one carton of three heater packs. For heater pack selection, see **Tab 15**.

Starters with electronic overload, see Modification Codes in **Tab 15**.

① Dual element fuse ratings.

② Class R fuse clips, except for Size 7 which uses Class L fuse clips. For starters with clips “Not Installed,” select fuse clip kit on **Page V10-T6-8**.

③ To order without the START pushbutton, add modification code **P6**.

④ For Compact NEMA Size 1 or Size 4 Pump Panel, add modification code **C60**. (Example: ECN5412AAA-C60).

Compact NEMA Size 1 and Size 4 Starters Electrical Life at Rated Continuous Current

NEMA Size	Rated Current (Amp) AC3/AC4	Operations
1C	27/150	2,500,000/40,000
1	27/153	5,000,000/110,000
4C	135/516	500,000/40,000
4	135/822	800,000/70,000

For Other Volts and Hertz Applications

For other than listed volts and hertz, select required controller by catalog number and replace the magnet coil alpha designation, eighth digit in catalog number, with proper code suffix from the table below.

Example: For 600V 60 Hz coil, change ECN5412**B**AC to ECN5412**D**AC.

Coil Voltage

Coil Volts and Hertz	Suffix Code
120/60 or 110/50	A
240/60 or 220/50	B
480/60 or 440/50	C
600/60 or 550/50	D
208/60	E

Accessories

C351—Fuse Clip Selection—Three-Pole (Three Fuses)

NEMA Size	Motor Voltage	Fuse Clip Rating Amperes	Volts	Fuse Clip Kit for Field Installation in Non-Fusible Starter	
				For Non-Rejection Type Fuses Catalog Number	For Use with "R" Rejection Type Fuses Catalog Number
1	200/230	30	250	C351KC21	C351KC21R
	460-575		600	C351KD22-61	C351KD22-61R
2	200	60	250	C351KD22-61	C351KD22-61R
	230		250	C351KD22-61	C351KD22-61R
	460-575		600	C351KD62	C351KD62R
3	200	100	250	C351KE23-63	C351KE23-63 ①
	230		250	C351KE23-63	C351KE23-63 ①
	460-575		600	C351KE23-63	C351KE23-63 ①
4	200	200	250	C351KF24-64	C351KF24-64 ①
	230		250	C351KF24-64	C351KF24-64 ①
	460-575		600	C351KF24-64	C351KF24-64 ①

Note

① Fuse clip "R" rejection members for use with Class R fuses are supplied loose both in fuse clip kits and when fuse clips are factory installed.

Wiring Diagram

Typical Wiring Diagram

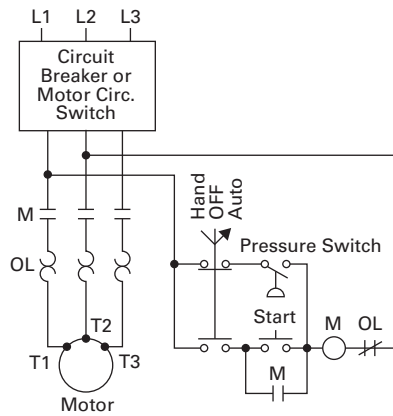

Freedom—Circuit Breaker

Product Description

- Three-phase magnetic
- Interchangeable heater OLR

These ECN55 pump controllers feature the Freedom line starters. They have a HAND/OFF/AUTO selector switch and START pushbutton mounted on the

enclosure and a RESET button on the front—wiring is as illustrated in the wiring diagram on **Page V10-T6-8**.

Type 3R enclosure does not include top conduit hubs. Hubs are available in kit form—see table on **Page V10-T6-5**.

If branch circuit protective device is 45A or greater, C320FBR1 fuse kit (panel mounted) may be required for control circuit protection per NEC 430-72.

Stainless steel enclosure may be ordered by changing the seventh digit to **A**. Type 3R rating will still apply.

Product Selection

Class ECN55—Combination Pump Panel—Circuit Breaker

NEMA Size	Motor Voltage	Max. hp 50/60 Hz	Circuit Breaker Size	Narrow Width ^① Catalog Number	Standard Width ^① Catalog Number
1 ^②	230	1	7A	ECN5512BAC-E14	ECN5512BAC
		3	15A	ECN5512BAD-E14	ECN5512BAD
		7-1/2	30A	ECN5512BAE-E14	ECN5512BAE
	460	1	3A	ECN5512CAB-E14	ECN5512CAB
		3	7A	ECN5512CAC-E14	ECN5512CAC
		5	15A	ECN5512CAD-E14	ECN5512CAD
2	230	10	50A	ECN5522BAF-E14	ECN5522BAF
	460	25		ECN5522CAF-E14	ECN5522CAF
3	230	30	100A	—	ECN5532BAG
	460	50		—	ECN5532CAG
4 ^②	230	50	150A	—	ECN5542BAH
	460	100		—	ECN5542CAH
5	230	60	250A	—	ECN5552BAJ
	230	100	400A	—	ECN5552BAK
	460	150	250A	—	ECN5552CAJ
	460	200	400A	—	ECN5552CAK
6	230	125	600A	—	ECN5562BAL
	230	200	800A	—	ECN5562BAM
	460	300	600A	—	ECN5562CAL
	460	400	800A	—	ECN5562CAM
7	230	250	^③	—	ECN5572BAU
	230	300		—	ECN5572BAU
	460	500		—	ECN5572CAU
	460	600		—	ECN5572CAU

Notes

Starters do not include heater packs. Select one carton of three heater packs. For heater pack selection, see **Tab 15**.

^① To order without the START pushbutton, add modification code **P6**.

^② For Compact NEMA Size 1 or Size 4 Pump Panel, add modification code **C60**. (Example: ECN5412AAA-C60).

**Compact NEMA Size 1 and Size 4 Starters
Electrical Life at Rated Continuous Current**

NEMA Size	Rated Current (Amp) AC3/AC4	Operations
1C	27/150	2,500,000/40,000
1	27/153	5,000,000/110,000
4C	135/516	500,000/40,000
4	135/822	800,000/70,000

^③ Supply hp, voltage, FLA and whether motor is design E or not when ordering the starter.

For Other Volts and Hertz Applications

For other than listed volts and hertz, select required controller by catalog number and replace the magnet coil alpha designation, eighth digit in catalog number, with proper code suffix from the table below.

Example: For 600V 60 Hz coil, change ECN5512**C**AC to ECN5512**D**AC.

Coil Voltage

Coil Volts and Hertz	Suffix Code
120/60 or 110/50	A
240/60 or 220/50	B
480/60 or 440/50	C
600/60 or 550/50	D
208/60	E

6.1

Pump Panels

Industrial Pump Panels

Dimensions

Approximate Dimensions in Inches (mm)

Panel Space

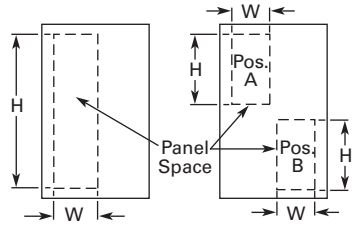

NEMA Sizes 1-4

NEMA Size 5

Panel Size	NEMA Size	Position (see figure above)	Width W	Height H
Narrow ①	1-2	—	5.5 (140)	6.0 (152)
Standard	1-3	—	8.5 (216)	26.0 (660)
	4	—	8.5 (216)	39.0 (991)
	5	A	10.0 (254)	22.0 (559)
		B	15.0 (381)	12.0 (305)
Oversize	1-2	—	12.0 (318)	39.0 (991)
	3	—	11.0 (279)	39.0 (991)

Note

① Space is between disconnect switch or circuit breaker and starter.

A200—Fusible Disconnect

Product Description

- Three-phase magnetic
- Interchangeable heater OLR

Standard ECN54 controllers have a HAND/OFF/AUTO selector switch and START and RESET pushbuttons mounted on the enclosure and are wired as illustrated on **Page V10-T6-12**.

Type 3R enclosure does not include top conduit hubs. Hubs are available in kit form—see table on **Page V10-T6-5**.

If branch circuit protective device is 45A or greater, C320FBR1 fuse kit (panel mounted) may be required for control circuit protection per NEC 430-72.

Stainless steel enclosure may be ordered by changing the seventh digit to **A**. Type 3R rating will still apply.

Product Selection

Class EC254—Combination A200 Pump Panel—Fusible Disconnect

NEMA Size	Motor Voltage ①	Max. hp 50/60 Hz	Fuse Clip Rating ②		Narrow Width ③	Standard Width ③
			Amperes	Volts	Catalog Number	Catalog Number
1	230	7-1/2	30	250	EC25412BAB-E14	EC25412BAB
	460	10		600	EC25412CAC-E14	EC25412CAC
	—	—	Not installed	Not installed	EC25412AAA-E14	EC25412AAA
2	230	15	60	250	EC25422BAD-E14	EC25422BAD
	460	25		600	EC25422CAE-E14	EC25422CAE
	—	—	Not installed	Not installed	EC25422AAA-E14	EC25422AAA
3	230	30	100	250	—	EC25432BAF
	460	50		600	—	EC25432CAG
	—	—	Not installed	Not installed	—	EC25432AAA
4	230	50	200	250	—	EC25442BAH
	460	100		600	—	EC25442CAJ
	—	—	Not installed	Not installed	—	EC25442AAA
5	230	100	400	250	—	EC25452BAK
	460	200		600	—	EC25452CAL
6	230	200	600	250	—	EC25462BAM
	460	400		600	—	EC25462CAN
7	460	600	1200	600	—	EC25472CAQ

Notes

Starters do not include heater packs. Select 1 carton of 3 heater packs. For heater pack selection, see **Tab 15**.

① Dual element fuse ratings.

② Class R fuse clips, except for Size 7 which uses Class L fuse clips. For starters with clips "Not Installed", select fuse clip kit on **Page V10-T6-8**.

③ To order without the START pushbutton, add modification code **P6**.

For Other Volts and Hertz Applications

For other than listed volts and hertz, select required controller by catalog number and replace the magnet coil alpha designation, eighth digit in catalog number, with proper code suffix from the table below.

Example: For 600V 60 Hz coil, change EC25412**B**AC to EC25412**D**AC.

Coil Voltage

Coil Volts and Hertz	Suffix Code
120/60 or 110/50	A
240/60 or 220/50	B
480/60 or 440/50	C
600/60 or 550/50	D
208/60	E

6.1

Pump Panels

Industrial Pump Panels

Wiring Diagram

Typical Wiring Diagram

6

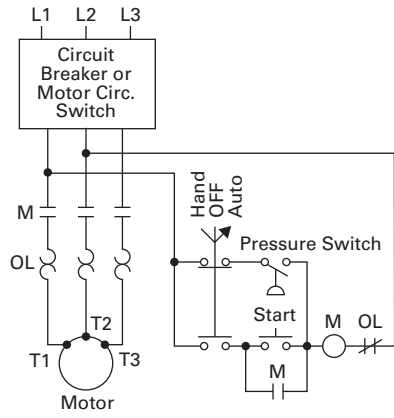

A200—Circuit Breaker

Product Description

- Three-phase magnetic
- Interchangeable heater OLR

These ECN55 pump controllers feature the A200 starters. They have a HAND/OFF/AUTO selector switch and START pushbutton mounted on the enclosure and a RESET button on the front—wiring is as illustrated in the wiring diagram on **Page V10-T6-12**.

Type 3R enclosure does not include top conduit hubs. Hubs are available in kit form—see **Page V10-T6-5**.

If branch circuit protective device is 45A or greater, C320FBR1 fuse kit (panel mounted) may be required for control circuit protection per NEC 430-72.

Stainless steel enclosure may be ordered by changing the seventh digit to **A**. Type 3R rating will still apply.

Product Selection

Class EC255—Combination A200 Pump Panel—Circuit Breaker

NEMA Size	Motor Voltage	Max. hp 50/60 Hz	Circuit Breaker Size	Narrow Width ^①	Standard Width ^②
				Catalog Number	Catalog Number
1	230	1	7A	EC25512BAC-E14	EC25512BAC
		3	15A	EC25512BAD-E14	EC25512BAD
		7-1/2	30A	EC25512BAE-E14	EC25512BAE
	460	1	3A	EC25512CAB-E14	EC25512CAB
		3	7A	EC25512CAC-E14	EC25512CAC
		5	15A	EC25512CAD-E14	EC25512CAD
2	230	10	50A	EC25522BAF-E14	EC25522BAF
		25		EC25522CAF-E14	EC25522CAF
		30	100A	—	EC25532BAG
	460	50		—	EC25532CAG
		50	150A	—	EC25542BAH
		100		—	EC25542CAH
3	230	60	250A	—	EC25552BAJ
		100	400A	—	EC25552BAK
		150	250A	—	EC25552CAJ
	460	200	400A	—	EC25552CAK
		125	600A	—	EC25562BAL
		200	800A	—	EC25562BAM
4	230	300	600A	—	EC25562CAL
		400	800A	—	EC25562CAM
	460	250	③	—	EC25572BAU
		300		—	EC25572BAU
5	230	500		—	EC25572CAU
		600		—	EC25572CAU

For Other Volts and Hertz Applications

For other than listed volts and hertz, select required controller by catalog number and replace the magnet coil alpha designation, eighth digit in catalog number with proper code suffix from the table below.

Example: For 600V 60 Hz coil, change EC25512**C**AC to EC25512**D**AC.

Coil Voltage

Coil Volts and Hertz	Suffix Code
120/60 or 110/50	A
240/60 or 220/50	B
480/60 or 440/50	C
600/60 or 550/50	D
208/60	E

Notes

Starters do not include heater packs. Select one carton of three heater packs. For heater pack selection, see **Tab 15**.

- ① To order without the START pushbutton, add modification code **P6**.
- ② Consult factory in the event ground fault protection is required.
- ③ Supply hp, voltage, FLA and whether motor is design E or not when ordering the starter.

6.1

Pump Panels

Industrial Pump Panels

Dimensions

Approximate Dimensions in Inches (mm)

Panel Space

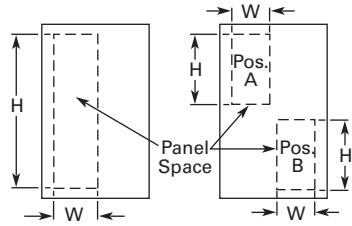

NEMA Sizes 1-4

NEMA Size 5

Panel Size	NEMA Size	Position (see figure above)	Width W	Height H
Narrow ^①	1-2	—	5.5 (140)	6.0 (152)
Standard	1-3	—	8.5 (216)	26.0 (660)
	4	—	8.5 (216)	39.0 (991)
	5	A	10.0 (254)	22.0 (559)
		B	15.0 (381)	12.0 (305)
Oversize	1-2	—	12.0 (318)	39.0 (991)
	3	—	11.0 (279)	39.0 (991)

Note

^① Space is between disconnect switch or circuit breaker and starter.

Vacuum Starter Pump Panels



Contents

<i>Description</i>	<i>Page</i>
Vacuum Starter Pump Panels	
Product Selection	V10-T6-16
Wiring Diagram	V10-T6-16

Freedom—Fusible Disconnect and Circuit Breaker

Product Description

- Three-phase magnetic
- Interchangeable heater OLR

Standard ECV54, 55 controllers have a HAND/OFF/AUTO selector switch and START pushbutton mounted on the enclosure and are wired as illustrated on **Page V10-T6-16**.

Type 3R enclosure does not include top conduit hubs. Hubs are available in kit form—see **Page V10-T6-5**.

If branch circuit protective device is 45A or greater, C320FBR1 fuse kit (panel mounted) may be required for control circuit protection per NEC 430-72.

Standards and Certifications

Note: See **Tab 17** for additional information on standards and certifications that apply to all enclosed control products.

- UL Listed
- cUL (indicates appropriate CSA Standard investigation)
- ABS Type Approved
- OSHPD Certified (OSP-0015-10)

Additional Reference

<i>Description</i>	<i>Page</i>
Kits	V10-T6-5
Dimensions	Tab 14
Accessories and Modifications	Tab 15

Product Selection

Class ECV54—Combination Vacuum Pump Panel—Fusible Disconnect

NEMA Size	Motor Voltage	Max. hp 50/60 Hz	Fuse Clip Rating Amperes	Volts	With START Pushbutton Catalog Number
4	230	50	200	250	ECV5442BAH
	460	100		600	ECV5442CAJ
5	230	100	400	250	ECV5452BAK
	460	200		600	ECV5452CAL
6	230	200	600	250	ECV5462BAM
	460	400		600	ECV5462CAN

Class ECV55—Combination Vacuum Pump Panel—Circuit Breaker

NEMA Size	Motor Voltage	Max. hp 50/60 Hz	Circuit Breaker Size	With START Pushbutton Catalog Number
4	230	50	150A	ECV5542BAH
	460	100		ECV5542CAH
5	230	75	250A	ECV5552BAJ
		100	400A	ECV5552BAK
	460	150	250A	ECV5552CAJ
		200	400A	ECV5552CAK
6	230	200	600A	ECV5562BAL
	460	400		ECV5562CAL

Note

Starters do not include heater packs. Select one carton of three heater packs. For heater pack selection, see Tab 15.

Wiring Diagram

Typical Wiring Diagram

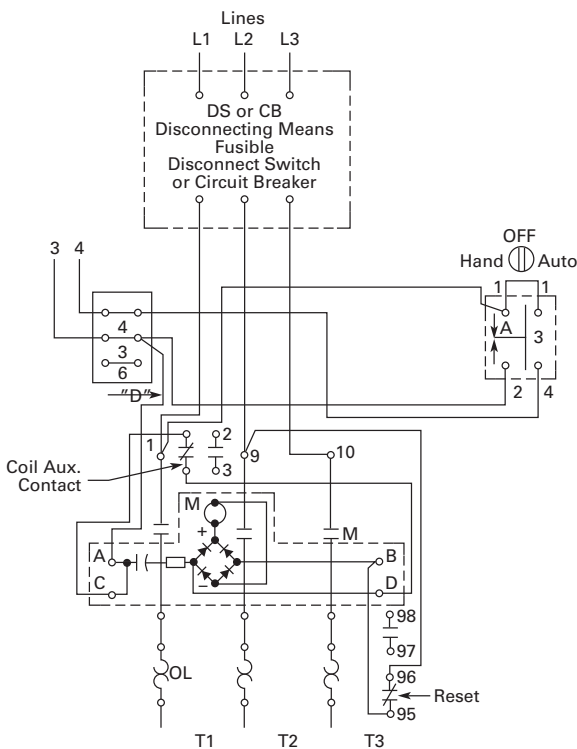

Irrigation Pump Panel—C440 SSOL



Contents

Description	Page
Irrigation Pump Panels	
Catalog Number Selection	V10-T6-18
Pump Panels—Interchangeable Heater Overload	
Product Selection	V10-T6-19
Pump Panels—Solid-State Overload	
Product Selection	V10-T6-20
Wiring Diagram	V10-T6-22

Product Description

Eaton’s irrigation pump controllers are combination starters designed to meet the requirements of the agricultural industry. The enclosure is UL Type 3R rated to provide weathertight protection and is available in two sizes. Irrigation application specific accessories and modifications are available to fit the customer’s requirements.

The irrigation pump panels use Freedom series motor starting technology to control motors up to 100 hp at 460V. These controllers have two styles of overload protection available, interchangeable heater and solid-state overload (SSOL).

Features

- The interchangeable heater overload (C306) uses individual heater packs to allow customers the ability to use various heater styles
- The solid-state overload relay (C440) provides enhanced protection and adjustment ranges as compared to bimetallic overload relays. Trip Class 10, 20, and 30 are available, along with a very wide trip current range to make setup very easy

Standards and Certifications

Note: See **Tab 17** for additional information on standards and certifications that apply to all enclosed control products.

- UL Listed
- cUL Listed (indicates appropriate CSA Standard investigation)
- ABS Type Approved
- OSHPD Certified (OSP-0015-10)

Additional Reference

Kits	V10-T6-5
Dimensions	Tab 14
Accessories and Modifications	Tab 15

6.3

Pump Panels

Irrigation Pump Panels

Catalog Number Selection

Irrigation Pump Panel

6

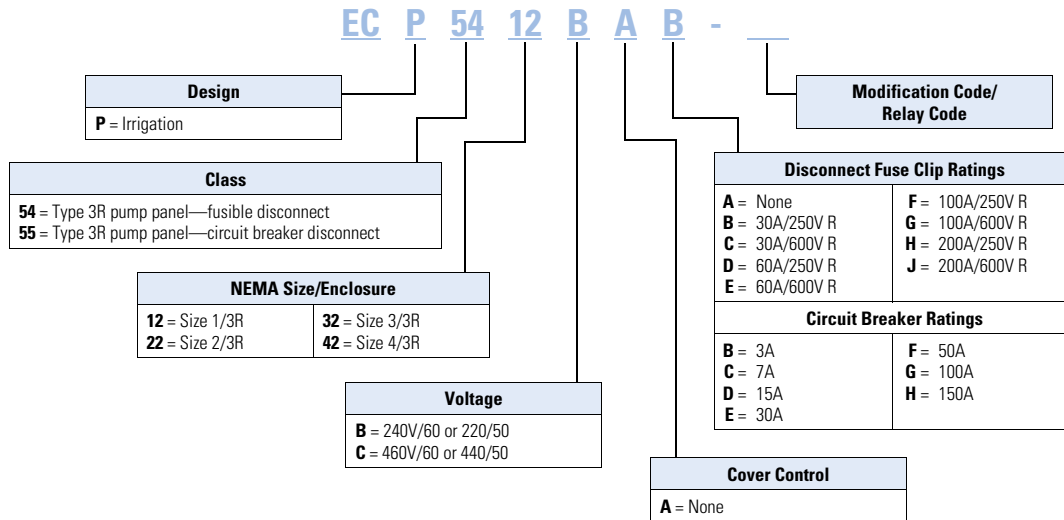

Pump Panels—Interchangeable Heater Overload

Product Selection

Standard ECP54 controllers have a HAND/OFF/AUTO selector switch and START

pushbutton mounted on the enclosure and are wired as illustrated on **Page V10-T6-22**.

Class ECP54—Combination Irrigation Pump Panel—Fusible Disconnect

NEMA Size	Motor Voltage ①	Max. hp 50/60 Hz	Fuse Clip Rating ②		Standard Width Catalog Number
			Amperes	Volts	
1 ③	230	7-1/2	30	250	ECP5412BAB
	460	10		600	ECP5412CAC
	—	—	Not installed	Not installed	ECP5412AAA
2	230	15	60	250	ECP5422BAD
	460	25		600	ECP5422CAE
	—	—	Not installed	Not installed	ECP5422AAA
3	230	30	100	250	ECP5432BAF
	460	50		600	ECP5432CAG
	—	—	Not installed	Not installed	ECP5432AAA

For Other Volts and Hertz Applications

For other than listed volts and hertz, select required controller by catalog number and replace the magnet coil alpha designation, eighth digit in catalog number with proper code suffix from the table below.

Example: For 600V 60 Hz coil, change ECP5412BAB to ECP5412DAB.

Coil Voltage

Coil Volts and Hertz	Suffix Code
120/60 or 110/50	A
240/60 or 220/50	B
480/60 or 440/50	C
600/60 or 550/50	D
208/60	E

Fuse Clips

C351—Fuse Clip Selection—Three-Pole (Three Fuses)

NEMA Size	Motor Voltage	Fuse Clip Rating Amperes	Volts	Fuse Clip Kit for Field Installation in Non-Fusible Starter	
				For Non-Rejection Type Fuses Catalog Number	For Use with "R" Rejection Type Fuses Catalog Number
1	200/230	30	250	C351KC21	C351KC21R
	460-575		600	C351KD22-61	C351KD22-61R
2	200	60	250	C351KD22-61	C351KD22-61R
	230			C351KD22-61	C351KD22-61R
	460-575			C351KD62	C351KD62R
3	200	100	250	C351KE23-63	C351KE23-63 ④
	230			C351KE23-63	C351KE23-63 ④
	460-575		600	C351KE23-63	C351KE23-63 ④

Notes

Starters do not include heater packs. Select one carton of three heater packs. For heater pack selection, see **Tab 15**.

- ① Dual element fuse ratings.
- ② Class R fuse clips.
- ③ For Compact NEMA Size 1 or Size 4 Pump Panel, add modification code **C60**. (Example: ECN5412AAA-C60).

Compact NEMA Size 1 and Size 4 Starters Electrical Life at Rated Continuous Current

NEMA Size	Rated Current (Amp)	
	AC3/AC4	Operations
1C	27/150	2,500,000/40,000
1	27/153	5,000,000/110,000

- ④ Fuse clip "R" rejection members for use with Class R fuses are supplied loose both in fuse clip kits and when fuse clips are factory installed.

Pump Panels—Solid-State Overload

Product Selection

Class ECP54—Combination Irrigation Pump Panel with Solid-State Overload—Fusible Disconnect ^①

Motor Voltage	NEMA Size	Maximum hp	Fuse Clip Amperes	Trip Range	Catalog Number
240V	1 ^②	1	30	1.0–5.0	ECP5412BAB-R63/B
		3		4–20	ECP5412BAB-R63/C
		7-1/2		9–45	ECP5412BAB-R63/D
	2	10	60	9–45	ECP5422BAD-R63/D
		15			ECP5422BAD-R63/D
	3	25	100	20–100	ECP5432BAF-R63/E
480V	1 ^②	1	30	1.0–5.0	ECP5412CAC-R63/B
		2		ECP5412CAC-R63/B	
		5		4–20	ECP5412CAC-R63/C
		10		ECP5412CAC-R63/C	
	2	20	60	9–45	ECP5422CAE-R63/D
		25			ECP5422CAE-R63/D
	3	50	100	20–100	ECP5432CAG-R63/E

Class ECP55—Combination Irrigation Pump Panel with Solid-State Overload—Circuit Breaker ^①

Motor Voltage	NEMA Size	Maximum hp	Breaker Rating	Trip Range	Catalog Number
240V	1 ^②	1	7	1.0–5.0	ECP5512BAC-R63/B
		3	15	4–20	ECP5512BAD-R63/C
		7-1/2	30	9–45	ECP5512BAE-R63/D
	2	10	50	9–45	ECP5522BAF-R63/D
		15	20–100	ECP5522BAF-R63/E	
	3	25	100	20–100	ECP5532BAG-R63/E
	4 ^②	50	28–140	ECP5532BAH-R63/F	
480V	1 ^②	1	30	1.0–5.0	ECP5512CAB-R63/B
		2		ECP5512CAC-R63/B	
		5		4–20	ECP5512CAD-R63/C
		10		ECP5512CAE-R63/C	
	2	20	60	9–45	ECP5522CAE-R63/D
		25			ECP5522CAF-R63/D
	3	50	100	20–100	ECP5532CAG-R63/E
	4 ^②	100	150	28–140	ECP5532CAG-R63/F

Note

^① Motor FLA based on NEC Table.

^② For Compact NEMA Size 1 or Size 4 Pump Panel, add modification code **C60**. (Example: ECN5412AAA-C60).

Compact NEMA Size 1 and Size 4 Starters Electrical Life at Rated Continuous Current

NEMA Size	Rated Current (Amp) AC3/AC4	Operations
1C	27/150	2,500,000/40,000
1	27/153	5,000,000/110,000
4C	135/516	500,000/40,000
4	135/822	800,000/70,000

Class ECP55—Combination Irrigation Pump Panel—Circuit Breaker

Motor Voltage	NEMA Size	Maximum hp	Breaker Rating	Catalog Number	Motor Voltage	NEMA Size	Maximum hp	Breaker Rating	Catalog Number
240V	1 ①	1	7	ECP5512BAC	480V	1 ①	1	3	ECP5512CAB
		3	15	ECP5512BAD			3	7	ECP5512CAC
		7-1/2	30	ECP5512BAE			5	15	ECP5512CAD
	2	10	50	ECP5522BAF		2	10	30	ECP5512CAE
		15	70	ECP5522BAW			10	30	ECP5522CAE
	3	25	100	ECP5532BAG		25	50	ECP5522CAF	
	4 ①	50	150	ECP5542BAH		3	50	100	ECP5532CAG
				4 ①	100	175	ECP5542CAN		

Overload Relays

Freedom Solid-State Overload Relays

NEMA Size	Full Load Current Adjustment Range (A)	Three-Phase without Ground Fault	Three-Phase with Ground Fault
		Auto/Manual Reset Overload Selectable Class 10/20/30	Auto/Manual Reset Overload Selectable Class 10/20/30
00	0.33–1.65 ②	R63/A	R64/A
	1–5	R63/B	R64/B
	4–20	R63/C	R64/C
0 and 1	0.33–1.65 ②	R63/A	R64/A
	1–5	R63/B	R64/B
	4–20	R63/C	R64/C
	9–45	R63/D	R64/D
2	9–45	R63/D	R64/D
3	20–100	R63/E	R64/E
4	28–140	R63/F	R64/F
5	60–300 ③	R63/G	R64/G
6	120–600 ④	R63/H	R64/H

Notes

① Compact NEMA Size 1 or Size 4 Pump Panel, add modification code **C60**. (Example: ECN5412AAA-**C60**).

**Compact NEMA Size 1 and Size 4 Starters
Electrical Life at Rated Continuous Current**

NEMA Size	Rated Current (Amp)	
	AC3/AC4	Operations
1C	27/150	2,500,000/40,000
1	27/153	5,000,000/110,000
4C	135/516	500,000/40,000
4	135/822	800,000/70,000

② Not UL Listed.

③ NEMA Size 5 starter available with 60–300A panel mounted CTs. Starter as an assembled unit with 1–5A C440 overload relay (C440A1A005SELAX or C440A2A005SELAX).

④ NEMA Size 6 starter available with 120–600A panel mounted CTs. Starter as an assembled unit with 1–5A C440 overload relay (C440A1A005SELAX or C440A2A005SELAX).

Features:

- Self powered
- Phase loss protection
- Current adjustment knob
- ±1% repeat accuracy
- 1NO and 1NC isolated contacts
- Predictive indication
- Enhanced protection and monitoring
- Communication capabilities

6.3

Pump Panels

Irrigation Pump Panels

Wiring Diagram

Typical Wiring Diagram

6

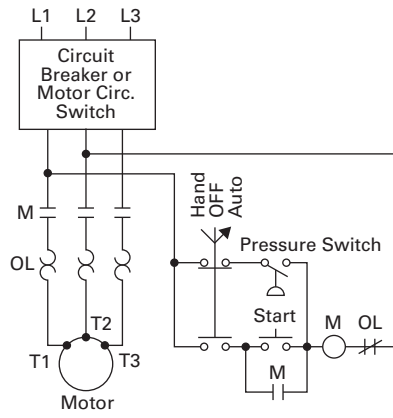

Contents

Description	Page
Duplex Pump Panels	
Catalog Number Selection	V10-T6-24
Cover Control	V10-T6-25
Non-Combination	
Features	V10-T6-26
Product Selection	V10-T6-26
Combination	
Features	V10-T6-27
Product Selection	V10-T6-27

Product Description

Eaton’s duplex pump panels are controllers with or without disconnect, and designed to meet the requirement for two alternating pumps in critical installations. All duplex pump panels are provided standard with two three-phase magnetic starters and an automatic alternator to provide equal pump wear. During periods for heavy demand, both pumps will operate.

The enclosure options include UL Type 1, 12, 3R, or 4X.

Standards and Certifications

Note: See **Tab 17** for additional information on standards and certifications that apply to all enclosed control products.

- UL Listed
- cUL Listed (indicates appropriate CSA Standard investigation)
- ABS Type Approved
- OSHPD Certified (OSP-0015-10)

Additional Reference

Other Magnet Coils	V10-T6-24
Cover Control	V10-T6-25
Dimensions	Tab 14
Accessories and Modifications	Tab 15
Technical Data and Specifications	Tab 17

Catalog Number Selection

Freedom Duplex Pump Panels

6

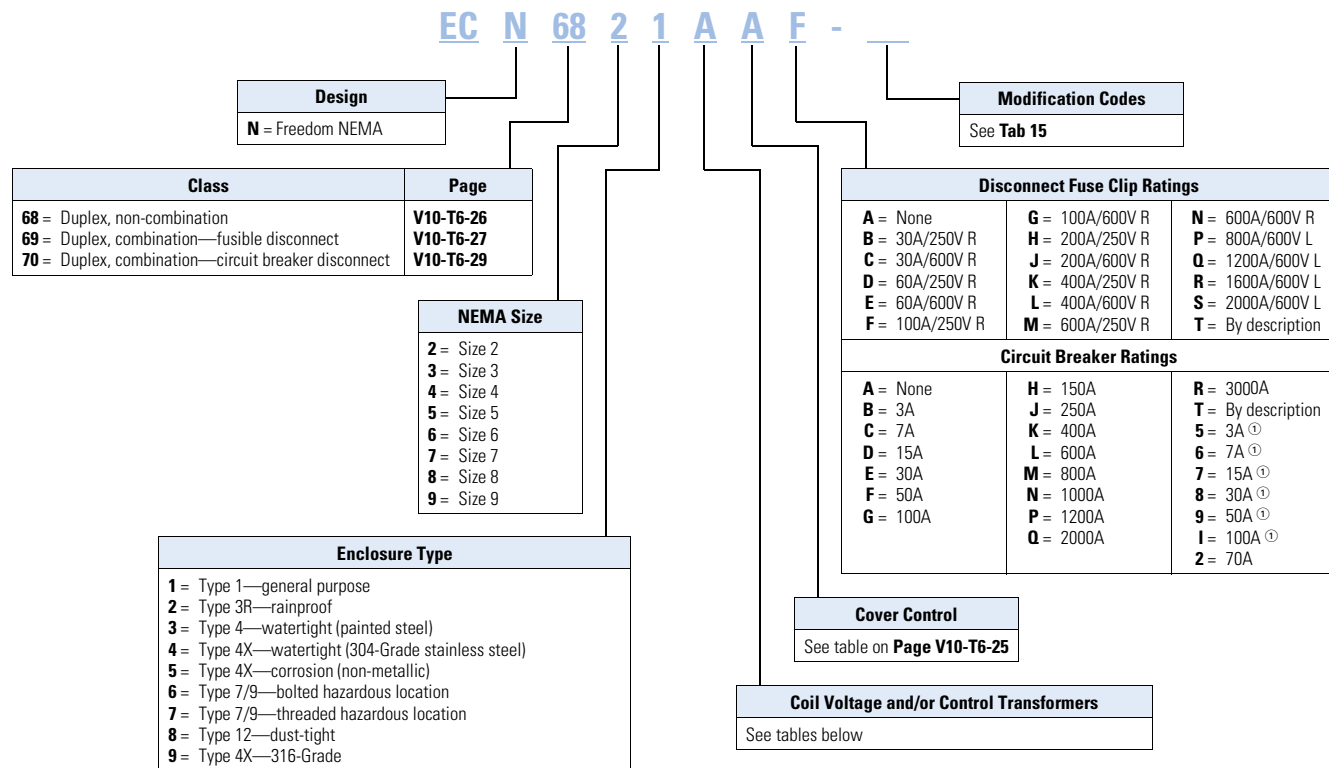

Magnetic Coil Codes (System Voltage) ②

Code	Magnet Coil	Code	Magnet Coil	Code	Magnet Coil
A	120/60110/50	K	240/50	U	24/50
B	240/60220/50	L	380/50	V	32/50
C	460/60440/50	M	415/50	W	48/60
D	575/60550/50	P	12 Vdc	X	104–120/60
E	208/60	Q	24 Vdc	Y	48/50
G	550/50	R	48 Vdc	Z	By description
H	277/60	S	125 Vdc		
J	208–240/60	T	24/60		

Control Power Transformer Codes (System Voltage)

Code	Primary	Secondary
B	240/480–220/440 wired for 240V	120/60–110/50
C	240/480–220/440 wired for 480V	120/60–110/50
D	600/60–550/50	120/60–110/50
E	208/60	120/60
H	277/60	120/60
L	380/50	110/50
M	415/50	110/50
Q	208/60	24
R	240/480–220/440 wired for 240V	24
S	240/480–220/440 wired for 480V	24
T	600/60	24
U	277/60	24
V	380/50	24
W	415/50	24
X	240/480/600 wired for 480V	120
Y	240/480/600 wired for 480V	24
Z	By description	—

Notes

- ① Use for Sizes 0–3, HMCP 600V applications only.
- ② When control power transformer modification codes (C1–C11) are used or when starter class includes CPT (that is, ECN07, 18) see table to the right for system voltage code.

Cover Control

Non-Reversing

Flange Control Kits

For on-the-job conversion of Type 1, 3R, 4X and 12 enclosed starters. Knockouts are provided on the Type 1 flange. Type 3R, 4X and 12 have prepunched holes with removable hole plugs.

Factory Installed Pilot Devices

To order factory installed pilot devices, change the 9th character of the catalog number to the alpha shown in the table below. Example: to order an **ECN0514CAA** with START/STOP pushbuttons and a red pilot light, change the **A** to a **C**, for example, **ECN0514CCA**.

Type 1 Cover Control



All Other Cover Controls



Non-Reversing Cover Control

Description	Factory Installed Flange Control			Field Installation Kits	
	Position 9 Alpha	Type 1 Non-Combination ①	All Others ②	Type 1 Non-Combination ① Catalog Number	All Others ② Catalog Number
No cover mounted pilot devices	A	■	■	C400GK0	—
START/STOP pushbuttons	B	■	■	C400GK1	C400T1
With red RUN pilot light	C	■	■	C400GK12 ③	—
With red RUN/green OFF lights	D	■	■	C400GK16 ③	—
ON/OFF pushbuttons	E	—	■	—	C400T2
With red RUN pilot light	F	—	■	—	—
With red RUN/green OFF lights	G	—	■	—	—
HAND/OFF/AUTO selector switch	H	■	■	C400GK3	C400T12
With red RUN pilot light	J	■	■	C400GK32 ③	—
With red RUN/green OFF lights	K	■	■	C400GK36 ③	—
START pushbutton	L	—	■	—	C400T3
ON pushbutton	M	—	■	—	C400T4
OFF pushbutton	N	—	■	—	C400T5
Red RUN pilot light	P	■	■	C400GK42 ③	C400T9 ③
Green OFF	Q	■	■	C400GK41 ③	C400T10 ③
Red RUN/green OFF pilot lights	R	■	■	C400GK46 ③	C400T11 ③
START/STOP selector switch	S	—	■	—	C400T13
With red RUN pilot light	T	—	■	—	—
With red RUN/green OFF lights	U	—	■	—	—
ON/OFF selector switch	V	—	■	—	C400T14
With red RUN pilot light	W	—	■	—	—
With red RUN/green OFF lights	X	—	■	—	—

Notes

- ① Type 1, NEMA Sizes 00–4 non-combination ONLY.
- ② Type 1, NEMA Sizes 5–9 non-combination PLUS all Type 3R, 4X, 12 non-combination PLUS all combination—NEMA sizes only.
- ③ Add code letter from the table below to catalog number for voltage—kits only. Example: C400T9B.

Rating	Code Letter	Rating	Code Letter	Rating	Code Letter
120V 60 Hz	A	240V 60 Hz	B	480V 60 Hz	C
208V 60 Hz	E	380V 50 Hz	L	600V 60 Hz	D

Non-Combination

Features

- Full voltage non-reversing non-combination
- Three-phase magnetic, three-pole
- Interchangeable heater OLR
- 600V maximum

Alternator

In normal operation, the alternator automatically selects alternate pumps for each succeeding cycle to equalize pump wear. During periods of heavy demand, both pumps will operate.

Product Selection

Class ECN68—Non-Combination Duplex Pump Panels with Automatic Alternator ^{①②}

NEMA Size	Motor Voltage	Max. hp Rating	Magnet Coil Voltage	Type 1 General Purpose Catalog Number	Type 3R Rainproof Catalog Number	Type 4X ^③ Watertight and Dust-Tight Stainless Steel Catalog Number	Type 12 Dust-Tight Industrial External Reset ^④ Catalog Number	Component Starter (Open) ^⑤ Catalog Number
0	—	—	120	ECN6801AAA	ECN6802AAA	ECN6804AAA	ECN6808AAA	AN16BN0AC
	200	3	208	ECN6801EAA	ECN6802EAA	ECN6804EAA	ECN6808EAA	AN16BN0EC
	230		240	ECN6801BAA	ECN6802BAA	ECN6804BAA	ECN6808BAA	AN16BN0BC
	460	5	480	ECN6801CAA	ECN6802CAA	ECN6804CAA	ECN6808CAA	AN16BN0CC
	575		600	ECN6801DAA	ECN6802DAA	ECN6804DAA	ECN6808DAA	AN16BN0DC
1	—	—	120	ECN6811AAA	ECN6812AAA	ECN6814AAA	ECN6818AAA	AN16DN0AB
	200	7-1/2	208	ECN6811EAA	ECN6812EAA	ECN6814EAA	ECN6818EAA	AN16DN0EB
	230		240	ECN6811BAA	ECN6812BAA	ECN6814BAA	ECN6818BAA	AN16DN0BB
	460	10	480	ECN6811CAA	ECN6812CAA	ECN6814CAA	ECN6818CAA	AN16DN0CB
	575		600	ECN6811DAA	ECN6812DAA	ECN6814DAA	ECN6818DAA	AN16DN0DB
2	—	—	120	ECN6821AAA	ECN6822AAA	ECN6824AAA	ECN6828AAA	AN16GN0AB
	200	10	208	ECN6821EAA	ECN6822EAA	ECN6824EAA	ECN6828EAA	AN16GN0EB
	230	15	240	ECN6821BAA	ECN6822BAA	ECN6824BAA	ECN6828BAA	AN16GN0BB
	460	25	480	ECN6821CAA	ECN6822CAA	ECN6824CAA	ECN6828CAA	AN16GN0CB
	575		600	ECN6821DAA	ECN6822DAA	ECN6824DAA	ECN6828DAA	AN16GN0DB
3	—	—	120	ECN6831AAA	ECN6832AAA	ECN6834AAA	ECN6838AAA	AN16KN0A
	200	25	208	ECN6831EAA	ECN6832EAA	ECN6834EAA	ECN6838EAA	AN16KN0E
	230	30	240	ECN6831BAA	ECN6832BAA	ECN6834BAA	ECN6838BAA	AN16KN0B
	460	50	480	ECN6831CAA	ECN6832CAA	ECN6834CAA	ECN6838CAA	AN16KN0C
	575		600	ECN6831DAA	ECN6832DAA	ECN6834DAA	ECN6838DAA	AN16KN0D
4	—	—	120	ECN6841AAA	ECN6842AAA	ECN6844AAA	ECN6848AAA	AN16NN0A
	200	40	208	ECN6841EAA	ECN6842EAA	ECN6844EAA	ECN6848EAA	AN16NN0E
	230	50	240	ECN6841BAA	ECN6842BAA	ECN6844BAA	ECN6848BAA	AN16NN0B
	460	100	480	ECN6841CAA	ECN6842CAA	ECN6844CAA	ECN6848CAA	AN16NN0C
	575		600	ECN6841DAA	ECN6842DAA	ECN6844DAA	ECN6848DAA	AN16NN0D

Notes

Starters do not include heater packs. Select two cartons of three heater packs (two overload relays—one for each motor). For heater pack selection, see **Tab 15**.

① Circuitry arranged for two-pole pilot devices.

② All duplexes come standard with alternator. To remove, add modification code **D12**.

③ The catalog numbers listed in the Type 4X column are for Type 4X 304-Grade stainless steel, as indicated by the **seventh** digit. Example: ECN6804AAA. To order Type 4X 316-Grade stainless steel, change that digit to **9**. To order Type 4 painted steel, change that digit to **3**. To order non-metallic, change that digit to **5**. For details on these alternate enclosures, see **Tab 13**.

④ All Type 12 enclosures are standardized with external reset. For internal reset, order modification code **R5**.

⑤ Requires two starters.

Combination

Features

- Full voltage non-reversing combination
- Three-phase magnetic, three-pole
- Interchangeable heater OLR
- 600V maximum

Alternator

In normal operation, the alternator automatically selects alternate pumps for each succeeding cycle to equalize pump wear. During periods of heavy demand, both pumps will operate.

Product Selection

Class ECN69—Combination Duplex Pump Panels with Automatic Alternator—Fusible Disconnect ^{①②}

NEMA Size	Motor Voltage	Max. hp Rating Dual Element Fuses	Magnet Coil Voltage ③	Fuse Clip Amps.	Type 1 General Purpose Catalog Number	Type 3R Rainproof Catalog Number	Type 4X ④ Watertight and Dust-Tight Stainless Steel Catalog Number	Type 12 Dust-Tight Industrial External Reset ⑤⑥	Component Starter (Open) ⑦ Catalog Number
0	230	3	120	30A	ECN6901AAB	ECN6902AAB	ECN6904AAB	ECN6908AAB	AN16BN0AC
	460	5			ECN6901AAC	ECN6902AAC	ECN6904AAC	ECN6908AAC	AN16BN0AC
	200	3	208		ECN6901EAB	ECN6902EAB	ECN6904EAB	ECN6908EAB	AN16BN0EC
	230		240		ECN6901BAB	ECN6902BAB	ECN6904BAB	ECN6908BAB	AN16BN0BC
	460	5	480		ECN6901CAC	ECN6902CAC	ECN6904CAC	ECN6908CAC	AN16BN0CC
	575		600		ECN6901DAC	ECN6902DAC	ECN6904DAC	ECN6908DAC	AN16BN0DC
1	230	7-1/2	120	30A	ECN6911AAB	ECN6912AAB	ECN6914AAB	ECN6918AAB	AN16DN0AB
	460	10			ECN6911AAC	ECN6912AAC	ECN6914AAC	ECN6918AAC	AN16DN0AB
	200	7-1/2	208		ECN6911EAB	ECN6912EAB	ECN6914EAB	ECN6918EAB	AN16DN0EB
	230		240		ECN6911BAB	ECN6912BAB	ECN6914BAB	ECN6918BAB	AN16DN0BB
	460	10	480		ECN6911CAC	ECN6912CAC	ECN6914CAC	ECN6918CAC	AN16DN0CB
	575		600		ECN6911DAC	ECN6912DAC	ECN6914DAC	ECN6918DAC	AN16DN0DB
2	230	15	120	60A	ECN6921AAD	ECN6922AAD	ECN6924AAD	ECN6928AAD	AN16GN0AB
	460	25			ECN6921AAE	ECN6922AAE	ECN6924AAE	ECN6928AAE	AN16GN0AB
	200	10	208		ECN6921EAD	ECN6922EAD	ECN6924EAD	ECN6928EAD	AN16GN0EB
	230	15	240		ECN6921BAD	ECN6922BAD	ECN6924BAD	ECN6928BAD	AN16GN0BB
	460	25	480		ECN6921CAE	ECN6922CAE	ECN6924CAE	ECN6928CAE	AN16GN0CB
	575		600		ECN6921DAE	ECN6922DAE	ECN6924DAE	ECN6928DAE	AN16GN0DB
3	230	30	120	100A	ECN6931AAF	ECN6932AAF	ECN6934AAF	ECN6938AAF	AN16KN0A
	460	50			ECN6931AAG	ECN6932AAG	ECN6934AAG	ECN6938AAG	AN16KN0A
	200	25	208		ECN6931EAF	ECN6932EAF	ECN6934EAF	ECN6938EAF	AN16KN0E
	230	30	240		ECN6931BAF	ECN6932BAF	ECN6934BAF	ECN6938BAF	AN16KN0B
	460	50	480		ECN6931CAG	ECN6932CAG	ECN6934CAG	ECN6938CAG	AN16KN0C
	575		600		ECN6931DAG	ECN6932DAG	ECN6934DAG	ECN6938DAG	AN16KN0D
4	230	50	120	200A	ECN6941AAH	ECN6942AAH	ECN6944AAH	ECN6948AAH	AN16NN0A
	460	100			ECN6941AAJ	ECN6942AAJ	ECN6944AAJ	ECN6948AAJ	AN16NN0A
	200	40	208		ECN6941EAH	ECN6942EAH	ECN6944EAH	ECN6948EAH	AN16NN0E
	230	50	240		ECN6941BAH	ECN6942BAH	ECN6944BAH	ECN6948BAH	AN16NN0B
	460	100	480		ECN6941CAJ	ECN6942CAJ	ECN6944CAJ	ECN6948CAJ	AN16NN0C
	575		600		ECN6941DAJ	ECN6942DAJ	ECN6944DAJ	ECN6948DAJ	AN16NN0D

Notes

Starters do not include heater packs. Select two cartons of three heater packs (two overload relays—one for each motor). For heater pack selection, see **Tab 15**.

- ① Circuitry arranged for two-pole pilot devices.
- ② All duplexes come standard with alternator. To remove, add modification code **D12**.
- ③ For 200V and 575V motors—starters with 120V coil (for separate control) are available. To order, substitute the letter **A** for the eighth character of the listed catalog number.
- ④ The catalog numbers listed in the Type 4X column are for Type 4X 304-Grade stainless steel, as indicated by the **seventh** digit. Example: ECN6904AAB. To order Type 4X 316-Grade stainless steel, change that digit to **9**. To order Type 4 painted steel, change that digit to **3**. To order non-metallic, change that digit to **5**. For details on these alternate enclosures, see **Tab 13**.
- ⑤ All Type 12 enclosures are standardized with external reset. For internal reset, order modification code **R5**.
- ⑥ Type 12 enclosure is without safety door interlock.
- ⑦ Requires two starters.

Class ECN69—Combination Duplex Pump Panels with Automatic Alternator—Non-Fusible Disconnect ^{①②}

NEMA Size	Motor Voltage	Max. hp Rating Dual Element Fuses	Magnet Coil Voltage	Disconnect Amps.	Type 1 General Purpose Catalog Number	Type 3R Rainproof Catalog Number	Type 4X ^③ Watertight and Dust-Tight Stainless Steel Catalog Number	Type 12 Dust-Tight Industrial External Reset ^{④⑤} Catalog Number	Component Starter (Open) ^⑥ Catalog Number
0	—	—	120	30A	ECN6901AAA	ECN6902AAA	ECN6904AAA	ECN6908AAA	AN16BN0AC
	200	3	208		ECN6901EAA	ECN6902EAA	ECN6904EAA	ECN6908EAA	AN16BN0EC
	230		240		ECN6901BAA	ECN6902BAA	ECN6904BAA	ECN6908BAA	AN16BN0BC
	460	5	480		ECN6901CAA	ECN6902CAA	ECN6904CAA	ECN6908CAA	AN16BN0CC
	575		600		ECN6901DAA	ECN6902DAA	ECN6904DAA	ECN6908DAA	AN16BN0DC
1	—	—	120	30A	ECN6911AAA	ECN6912AAA	ECN6914AAA	ECN6918AAA	AN16DN0AB
	200	7-1/2	208		ECN6911EAA	ECN6912EAA	ECN6914EAA	ECN6918EAA	AN16DN0EB
	230		240		ECN6911BAA	ECN6912BAA	ECN6914BAA	ECN6918BAA	AN16DN0BB
	460	10	480		ECN6911CAA	ECN6912CAA	ECN6914CAA	ECN6918CAA	AN16DN0CB
	575		600		ECN6911DAA	ECN6912DAA	ECN6914DAA	ECN6918DAA	AN16DN0DB
2	—	—	120	60A	ECN6921AAA	ECN6922AAA	ECN6924AAA	ECN6928AAA	AN16GN0AB
	200	10	208		ECN6921EAA	ECN6922EAA	ECN6924EAA	ECN6928EAA	AN16GN0EB
	230	15	240		ECN6921BAA	ECN6922BAA	ECN6924BAA	ECN6928BAA	AN16GN0BB
	460	25	480		ECN6921CAA	ECN6922CAA	ECN6924CAA	ECN6928CAA	AN16GN0CB
	575		600		ECN6921DAA	ECN6922DAA	ECN6924DAA	ECN6928DAA	AN16GN0DB
3	—	—	120	100A	ECN6931AAA	ECN6932AAA	ECN6934AAA	ECN6938AAA	AN16KN0A
	200	25	208		ECN6931EAA	ECN6932EAA	ECN6934EAA	ECN6938EAA	AN16KN0E
	230	30	240		ECN6931BAA	ECN6932BAA	ECN6934BAA	ECN6938BAA	AN16KN0B
	460	50	480		ECN6931CAA	ECN6932CAA	ECN6934CAA	ECN6938CAA	AN16KN0C
	575		600		ECN6931DAA	ECN6932DAA	ECN6934DAA	ECN6938DAA	AN16KN0D
4	—	—	120	200A	ECN6941AAA	ECN6942AAA	ECN6944AAA	ECN6948AAA	AN16NN0A
	200	40	208		ECN6941EAA	ECN6942EAA	ECN6944EAA	ECN6948EAA	AN16NN0E
	230	50	240		ECN6941BAA	ECN6942BAA	ECN6944BAA	ECN6948BAA	AN16NN0B
	460	100	480		ECN6941CAA	ECN6942CAA	ECN6944CAA	ECN6948CAA	AN16NN0C
	575		600		ECN6941DAA	ECN6942DAA	ECN6944DAA	ECN6948DAA	AN16NN0D

Notes

Starters do not include heater packs. Select two cartons of three heater packs (two overload relays—one for each motor). For heater pack selection, see **Tab 15**.

- ① Circuitry arranged for two-pole pilot devices.
- ② All duplexes come standard with alternator. To remove, add modification code **D12**.
- ③ The catalog numbers listed in the Type 4X column are for Type 4X 304-Grade stainless steel, as indicated by the **seventh** digit. Example: ECN6904AAA. To order Type 4X 316-Grade stainless steel, change that digit to **9**. To order Type 4 painted steel, change that digit to **3**. To order non-metallic, change that digit to **5**. For details on these alternate enclosures, see **Tab 13**.
- ④ All Type 12 enclosures are standardized with external reset. For internal reset, order modification code **R5**.
- ⑤ Type 12 enclosure is without safety door interlock.
- ⑥ Requires two starters.

Class ECN70—Combination Duplex Pump Panels with Automatic Alternator—Circuit Breaker ^{①②}

NEMA Size	Motor Voltage	Max. hp Rating	Magnet Coil Voltage ^③	Circuit Breaker Size	Type 1 General Purpose Catalog Number	Type 3R Rainproof Catalog Number	Type 4X ^④ Watertight and Dust-Tight Stainless Steel Catalog Number	Type 12 Dust-Tight Industrial External Reset ^{⑤⑥} Catalog Number	Component Starter (Open) ^⑦ Catalog Number	
0	200	1	208	7A	ECN7001EAC	ECN7002EAC	ECN7004EAC	ECN7008EAC	AN16BN0EC	
		3		15A	ECN7001EAD	ECN7002EAD	ECN7004EAD	ECN7008EAD		
	230	1	240	7A	ECN7001BAC	ECN7002BAC	ECN7004BAC	ECN7008BAC	AN16BN0BC	
		3		15A	ECN7001BAD	ECN7002BAD	ECN7004BAD	ECN7008BAD		
	460	3/4	480	3A	ECN7001CAB	ECN7002CAB	ECN7004CAB	ECN7008CAB	AN16BN0CC	
		2		7A	ECN7001CAC	ECN7002CAC	ECN7004CAC	ECN7008CAC		
		5		15A	ECN7001CAD	ECN7002CAD	ECN7004CAD	ECN7008CAD		
	575	1	600	3A	ECN7001DAB	ECN7002DAB	ECN7004DAB	ECN7008DAB	AN16BN0DC	
		3		7A	ECN7001DAC	ECN7002DAC	ECN7004DAC	ECN7008DAC		
				15A	ECN7001DAD	ECN7002DAD	ECN7004DAD	ECN7008DAD		
	1	200	1	208	7A	ECN7011EAC	ECN7012EAC	ECN7014EAC	ECN7018EAC	AN16DN0EB
			2		15A	ECN7011EAD	ECN7012EAD	ECN7014EAD	ECN7018EAD	
7-1/2			30A		ECN7011EAE	ECN7012EAE	ECN7014EAE	ECN7018EAE		
230		1	240	7A	ECN7011BAC	ECN7012BAC	ECN7014BAC	ECN7018BAC	AN16DN0BB	
		2		15A	ECN7011BAD	ECN7012BAD	ECN7014BAD	ECN7018BAD		
		7-1/2		30A	ECN7011BAE	ECN7012BAE	ECN7014BAE	ECN7018BAE		
460		3/4	480	3A	ECN7011CAB	ECN7012CAB	ECN7014CAB	ECN7018CAB	AN16DN0CB	
		2		7A	ECN7011CAC	ECN7012CAC	ECN7014CAC	ECN7018CAC		
		5		15A	ECN7011CAD	ECN7012CAD	ECN7014CAD	ECN7018CAD		
		10		30A	ECN7011CAE	ECN7012CAE	ECN7014CAE	ECN7018CAE		
575		1	600	3A	ECN7011DAB	ECN7012DAB	ECN7014DAB	ECN7018DAB	AN16DN0DB	
		3		7A	ECN7011DAC	ECN7012DAC	ECN7014DAC	ECN7018DAC		
		7-1/2		15A	ECN7011DAD	ECN7012DAD	ECN7014DAD	ECN7018DAD		
		10		30A	ECN7011DAE	ECN7012DAE	ECN7014DAE	ECN7018DAE		
2		200	10	208	50A	ECN7021EAF	ECN7022EAF	ECN7024EAF	ECN7028EAF	AN16GN0EB
		230	15		240	ECN7021BAF	ECN7022BAF	ECN7024BAF	ECN7028BAF	AN16GN0BB
		460	25		480	ECN7021CAF	ECN7022CAF	ECN7024CAF	ECN7028CAF	AN16GN0CB
		575			600	ECN7021DAF	ECN7022DAF	ECN7024DAF	ECN7028DAF	AN16GN0DB
3	200	25	208	100A	ECN7031EAG	ECN7032EAG	ECN7034EAG	ECN7038EAG	AN16KN0E	
	230	30		240	ECN7031BAG	ECN7032BAG	ECN7034BAG	ECN7038BAG	AN16KN0B	
	460	50		480	ECN7031CAG	ECN7032CAG	ECN7034CAG	ECN7038CAG	AN16KN0C	
	575			600	ECN7031DAI	ECN7032DAI	ECN7034DAI	ECN7038DAI	AN16KN0D	
4	200	40	208	150A	ECN7041EAH	ECN7042EAH	ECN7044EAH	ECN7048EAH	AN16NN0E	
	230	50		240	ECN7041BAH	ECN7042BAH	ECN7044BAH	ECN7048BAH	AN16NN0B	
	460	100		480	ECN7041CAH	ECN7042CAH	ECN7044CAH	ECN7048CAH	AN16NN0C	
	575			600	ECN7041DAH	ECN7042DAH	ECN7044DAH	ECN7048DAH	AN16NN0D	

Notes

Starters do not include heater packs. Select two cartons of three heater packs (two overload relays—one for each motor). For heater pack selection, see **Tab 15**.

- ① Circuitry arranged for two-pole pilot devices.
- ② All duplexes come standard with alternator. To remove, add modification code **D12**.
- ③ For 200V and 575V motors—starters with 120V coil (for separate control) are available. To order, substitute the letter **A** for the eighth character of the listed catalog number.
- ④ The catalog numbers listed in the Type 4X column are for Type 4X 304-Grade stainless steel, as indicated by the **seventh** digit.
Example: ECN7004EAC. To order Type 4X 316-Grade stainless steel, change that digit to **9**. To order Type 4 painted steel, change that digit to **3**. To order non-metallic, change that digit to **5**. For details on these alternate enclosures, see **Tab 13**.
- ⑤ All Type 12 enclosures are standardized with external reset. For internal reset, order modification code **R5**.
- ⑥ Type 12 enclosure is without safety door interlock.
- ⑦ Requires two starters.