

# ONE-BOX™ Non-Metallic Outlet Boxes

NEW SIZES  
Available

*The Versatile Outlet Box for New or Old Work*

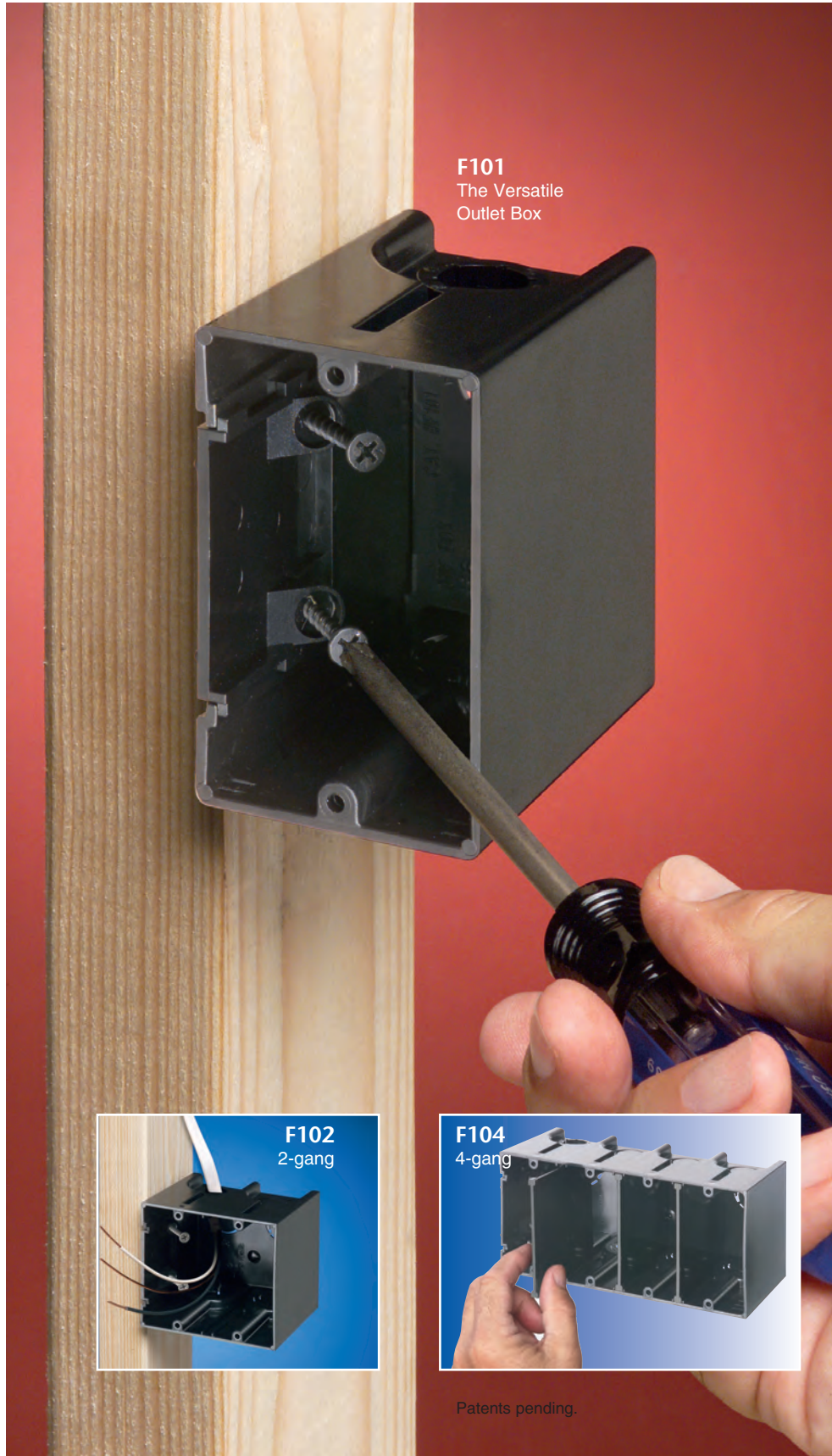

**F101**  
The Versatile  
Outlet Box

**F102**  
2-gang

**F104**  
4-gang

Patents pending.

Fast and easy to install, Arlington's versatile outlet box is the **ONE-BOX™** for new or old work.

It mounts directly to a wood or steel stud for a super secure installation.

Angled screws inside the ONE-BOX affix it firmly to the stud. It has no wings so there's no wobble.

**NEW WORK**

ONE-BOX set too far forward or back? No problem. Back the screws out and adjust it.

**OLD WORK**

ONE-BOX provides a secure installation. It mounts directly to the stud, not just the drywall.

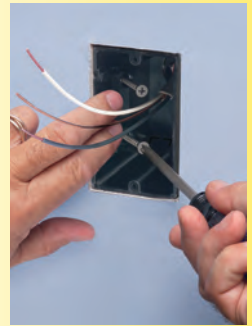

- Extra-large cubic inch capacity
- cULus Listed
- Single gang (horizontal and vertical) and multiple gang styles
- For power and low voltage applications with the F102D voltage separator installed
- Installed NM cable connector

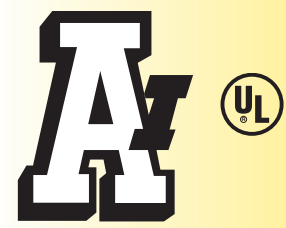

**Arlington**

1 Stauffer Industrial Park  
Scranton, PA 18517  
**800/233.4717**  
**Fax 570/562.0646**  
**www.aifittings.com**

# ONE-BOX™ Non-Metallic Outlet Boxes

*Secure Installation • Mounts Directly to a Wood or Steel Stud*

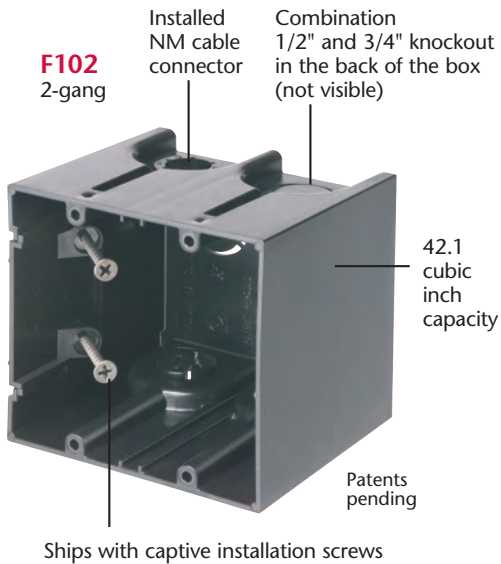

**1** Attach ONE-BOX to wood or steel stud with captive installation screws. If the box is too far forward or back, simply back the screws out and reposition it.

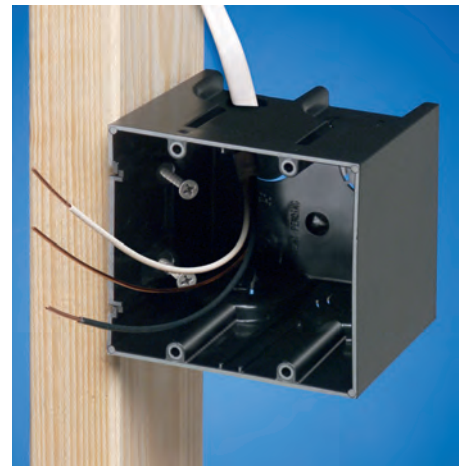

**2** Pull wire through the connector. (ships with installed NM cable connector)



**1** For old work, position ONE-BOX adjacent to stud. Use box as the template to cut hole.



**2** Pull wire. Insert ONE-BOX.

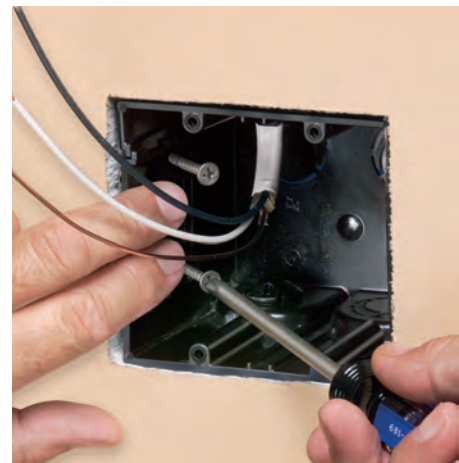

**3** Mount ONE-BOX directly to stud with shipped in place screws.

Catalog Number	UPC/DEI/NAED Mfg. #018997	Description Non-Metallic Outlet Box	Cubic Inch Capacity	Unit Pkg	Std Pkg
<b>F101</b>	43626	Single gang Vertical	22.0	50	50
<b>F102</b>	43640	2-gang	42.1	25	25
<b>F103</b>	43641	3-gang	61.2	20	20
<b>F104</b>	43642	4-gang	80.5	20	20
<b>F102D</b>	43544	Separator		25	25
<b>F101H</b>	43641	Single gang Horizontal	22.0	20	20



**Arlington**

1 Stauffer Industrial Park  
Scranton, PA 18517  
800/233.4717  
Fax 570/562.0646  
www.aifittings.com



Distributed by

# ONE-BOX™ Non-Metallic Outlet Boxes

NEW SIZES  
Available

*The Versatile Outlet Box for New or Old Work*

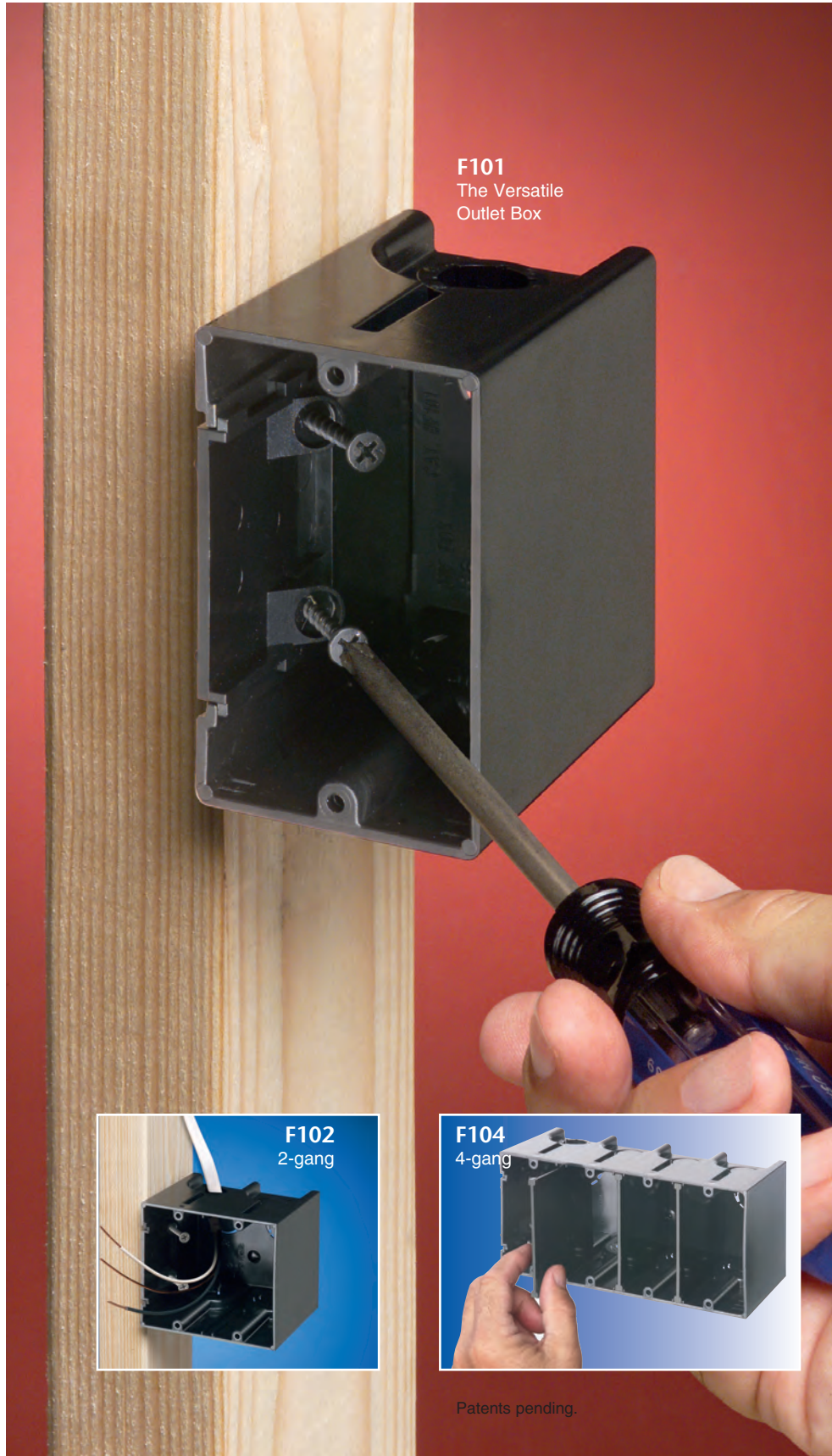

**F101**  
The Versatile  
Outlet Box

**F102**  
2-gang

**F104**  
4-gang

Patents pending.

Fast and easy to install, Arlington's versatile outlet box is the **ONE-BOX™** for new or old work.

It mounts directly to a wood or steel stud for a super secure installation.

Angled screws inside the ONE-BOX affix it firmly to the stud. It has no wings so there's no wobble.

**NEW WORK**

ONE-BOX set too far forward or back? No problem. Back the screws out and adjust it.

**OLD WORK**

ONE-BOX provides a secure installation. It mounts directly to the stud, not just the drywall.

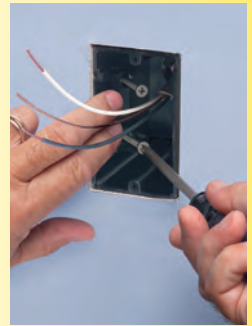

- Extra-large cubic inch capacity
- cULus Listed
- Single gang (horizontal and vertical) and multiple gang styles
- For power and low voltage applications with the F102D voltage separator installed
- Installed NM cable connector

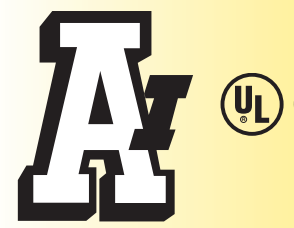

**Arlington**

1 Stauffer Industrial Park  
Scranton, PA 18517  
**800/233.4717**  
**Fax 570/562.0646**  
[www.aifittings.com](http://www.aifittings.com)

# ONE-BOX™ Non-Metallic Outlet Boxes

*Secure Installation • Mounts Directly to a Wood or Steel Stud*

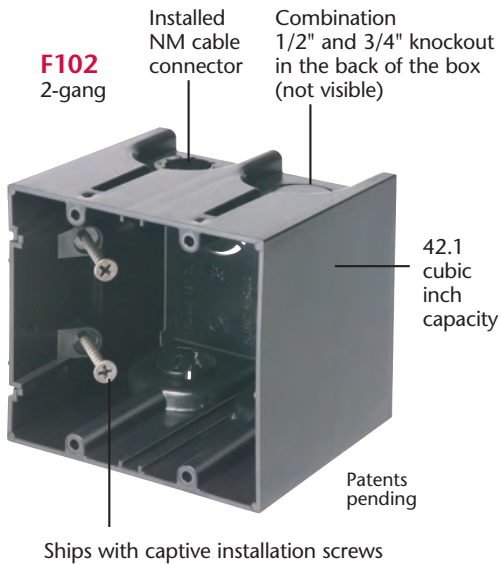

**1** Attach ONE-BOX to wood or steel stud with captive installation screws. If the box is too far forward or back, simply back the screws out and reposition it.

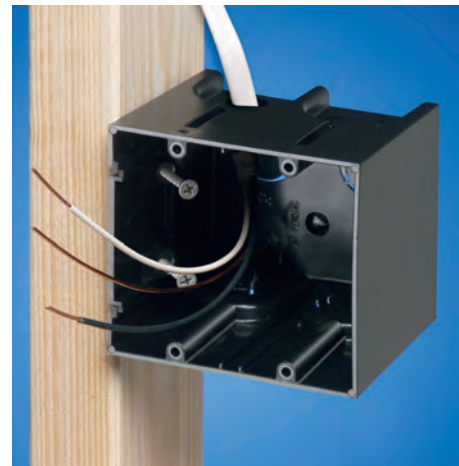

**2** Pull wire through the connector. (ships with installed NM cable connector)

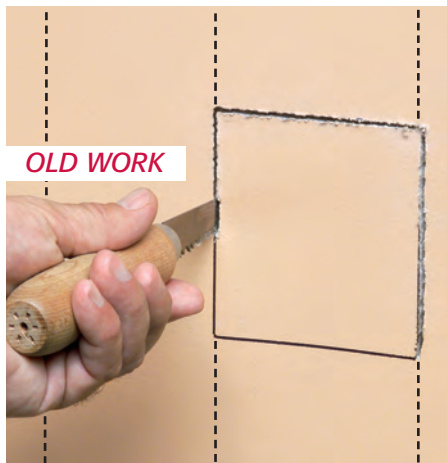

**1** For old work, position ONE-BOX adjacent to stud. Use box as the template to cut hole.

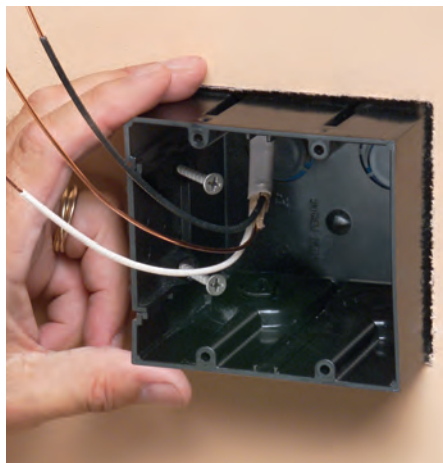

**2** Pull wire. Insert ONE-BOX.



**3** Mount ONE-BOX directly to stud with shipped in place screws.

Catalog Number	UPC/DEI/NAED Mfg. #018997	Description Non-Metallic Outlet Box	Cubic Inch Capacity	Unit Pkg	Std Pkg
<b>F101</b>	43626	Single gang Vertical	22.0	50	50
<b>F102</b>	43640	2-gang	42.1	25	25
<b>F103</b>	43641	3-gang	61.2	20	20
<b>F104</b>	43642	4-gang	80.5	20	20
<b>F102D</b>	43544	Separator		25	25
<b>F101H</b>	43641	Single gang Horizontal	22.0	20	20



**Arlington**

1 Stauffer Industrial Park  
Scranton, PA 18517  
800/233.4717  
Fax 570/562.0646  
www.aifittings.com



Distributed by