

NINETY DEGREE ANGLE FITTINGS

FOR 1 5/8" (41.3) WIDTH SERIES CHANNEL



1 5/8" Channels

Nuts & Hardware

General Fittings

P1026

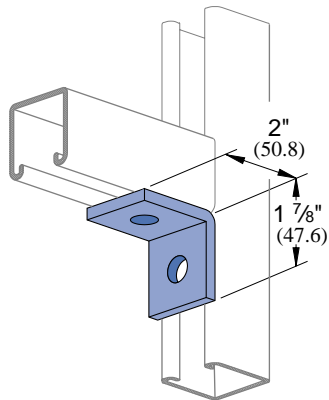

Wt/C 38 Lbs (17.2 kg)

P1723

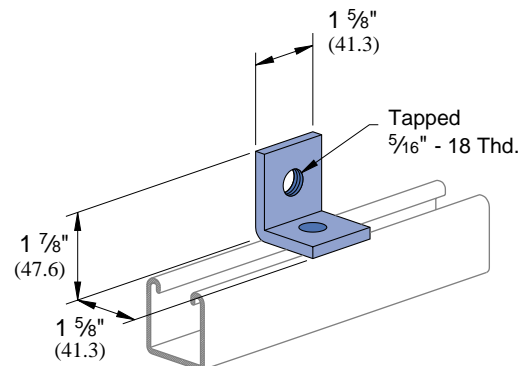

Wt/C 34 Lbs (15.4 kg)

Pipe/Conduit Supports

Electrical Fittings

Concrete Inserts

P1068

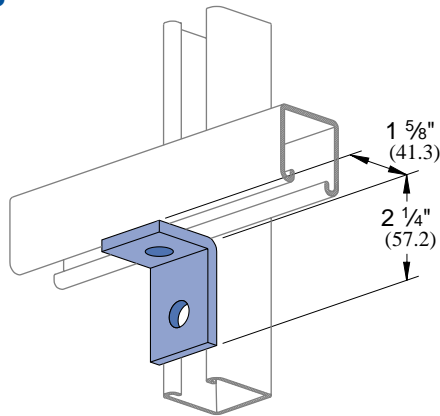

Wt/C 38 Lbs (17.2 kg)

P1281
P1282
P1283

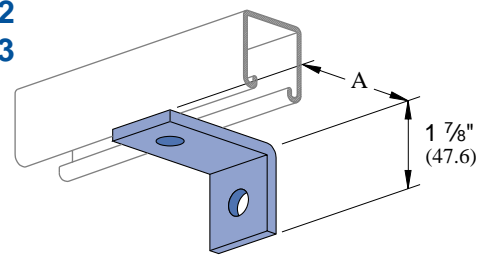

Part Number	"A" Dimension		Weight/C	
	In	mm	Lbs	kg
P1281	3	76.2	49	22.2
P1282	3 1/2	88.9	54	24.5
P1283	4	101.6	61	27.7

1 1/2" Framing System

13/16" Framing System

Spec. Metals & Fiberglass

P2626

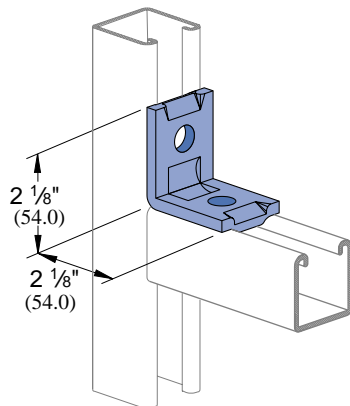

Wt/C 40 Lbs (18.1 kg)

P1315

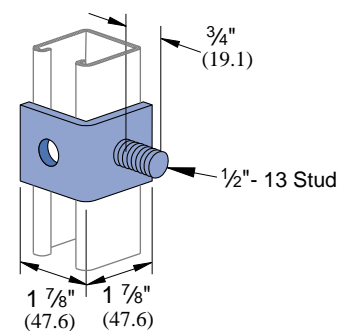

Wt/C 45 Lbs (20.4 kg)

Index

Hole Size	Hole Spacing	Width	Thickness
5/16" Diameter 14.3 mm	1 3/16" (20.6 mm) From End 1 7/8" (47.6 mm) On Center	1 5/8" 41.3 mm	1/4" 6.4 mm

GENERAL FITTINGS

FOR 1⁵/₈" (41 MM) WIDTH SERIES CHANNEL



1⁵/₈"
Channels

Nuts &
Hardware

General
Fittings

Pipe/Conduit
Supports

Electrical
Fittings

Concrete
Inserts

1¹/₄" Framing
System

1³/₁₆" Framing
System

Spec. Metals
& Fiberglass

Index

Page

Flat Plate
Fittings

82

Ninety Degree
Fittings

86

Angular
Fittings

93

"Z" Shape
Fittings

94

"U" Shape
Fittings

96

Wing Shape
Fittings

101

Post Bases

105

Brackets and
Braces

106

Beam Clamps

112

Trolleys

122

Special Application
Fittings

124

End Caps

126

Partition and
Display Fittings

127



MATERIAL

Fittings, unless noted, are made from hot-rolled, pickled and oiled steel plates, strip or coil, and conform to ASTM specifications A575, A576, A635, or A36. The fitting steel also meets the physical requirements of ASTM A570 GR 33. The pickling of the steel produces a smooth surface free from scale.

Many fittings are also available in stainless steel, aluminum and fiberglass. Consult factory for ordering information.

FINISHES

Fittings are available in: Perma-Green II (GR), electro-galvanized

(EG), conforming to ASTM B633 Type III SC1; Hot-dipped galvanized (HG), conforming to ASTM A123 or A153 and plain (PL).

APPLICATION

All parts drawings illustrate only one application of each fitting. In most cases many other applications are possible. The channels shown in the illustrations are P1000, 1⁵/₈" square, except where noted otherwise. All ⁵/₁₆" diameter holes use 1/2" x ¹⁵/₁₆" hex head cap screws and 1/2" nuts - P1010, P4010 or P5510 - depending on the channel used. Nuts and bolts are not included with the fitting and must be ordered separately.

DESIGN BOLT TORQUE

BOLT SIZE	1/4"	5/16"	3/8"	1/2"	5/8"	3/4"
FOOT LBS.	20	18	16	13	11	10
N·m	6	11	19	50	100	125

DIMENSIONS

Imperial dimensions are illustrated in inches. Metric dimensions are shown in parenthesis or as noted. Unless noted, all metric dimensions are in millimeters and rounded to one decimal place.

DESIGN LOAD

Design load data, where shown, is based on the ultimate strength of the connection with a safety factor of 2.5, unless otherwise noted.

DESIGN LOAD DATA

FOR 1 5/8" (41 MM) WIDTH SERIES CHANNEL



DESIGN LOAD DATA FOR TYPICAL UNISTRUT CHANNEL CONNECTIONS

90° Fittings (When used in position shown)										
Channel Thickness	P1026		P1026		P1325 P2235		P1458 P1579		P1346	
	Lbs	kN	Lbs	kN	Lbs	kN	Lbs	kN	Lbs	kN
12 ga.	1500	6.7	1000	4.4	2000	8.9	1500	6.7	2000	8.9
14 ga.	1000	4.4	650	2.9	2000	8.9	1000	4.4	1500	6.7
16 ga.	750	3.3	500	2.2	1500	6.7	1000	4.4	900	4.0

90° Fittings (When used in position shown)										Flat Plate Fittings
Channel Thickness	P2484		P1068		P1326		P1346		P1065	
	Lbs	kN	Lbs	kN	Lbs	kN	Lbs	kN	Lbs	kN
12 ga.	3000	13.3	500	2.2	500	2.2	1200	5.3	1000	4.4
14 ga.	2000	8.9	500	2.2	500	2.2	1200	5.3	800	3.6
16 ga.	1500	6.7	500	2.2	500	2.2	1000	4.4	600	2.7

Both ends of beams supported.

Load diagrams indicate up to three design loads, one for 12 gage sections (P1000), one for 14 gage sections (P1100), and one for 16 gage sections (P2000).

Load data is based on P1010 nut and 1/2" bolt.

Safety factor = 2 1/2 based on ultimate strength of connection.

1 5/8" Channels

Nuts & Hardware

General Fittings

Pipe/Conduit Supports

Electrical Fittings

Concrete Inserts

1 1/4" Framing System

1 3/16" Framing System

Spec. Metals & Fiberglass

Index

NINETY DEGREE ANGLE FITTINGS

FOR 1 5/8" (41.3) WIDTH SERIES CHANNEL



1 5/8" Channels

Nuts & Hardware

General Fittings

P1026

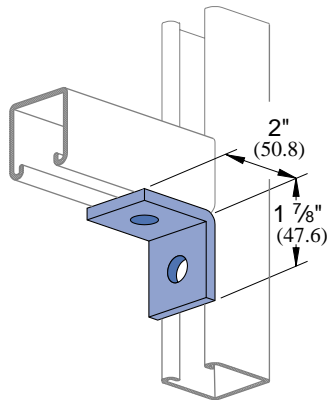

Wt/C 38 Lbs (17.2 kg)

P1723

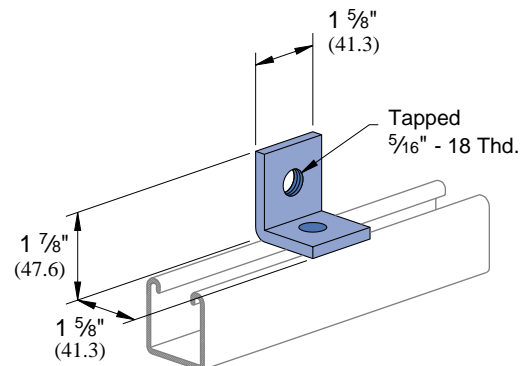

Wt/C 34 Lbs (15.4 kg)

Pipe/Conduit Supports

Electrical Fittings

Concrete Inserts

P1068

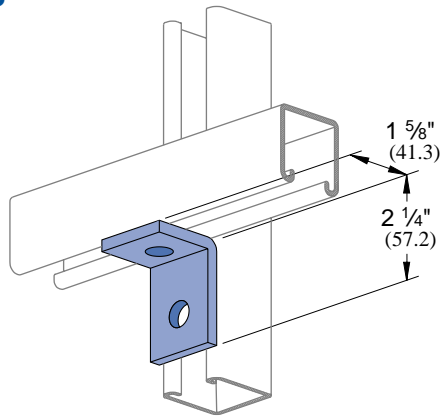

Wt/C 38 Lbs (17.2 kg)

P1281
P1282
P1283

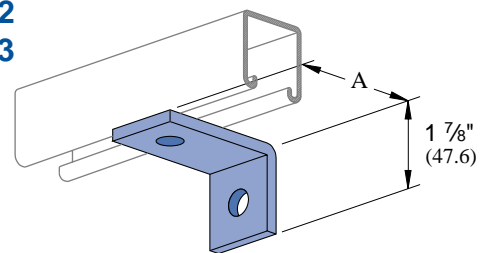

Part Number	"A" Dimension		Weight/C	
	In	mm	Lbs	kg
P1281	3	76.2	49	22.2
P1282	3 1/2	88.9	54	24.5
P1283	4	101.6	61	27.7

1 1/2" Framing System

13/16" Framing System

Spec. Metals & Fiberglass

P2626

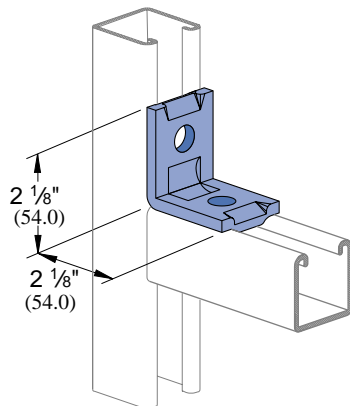

Wt/C 40 Lbs (18.1 kg)

P1315

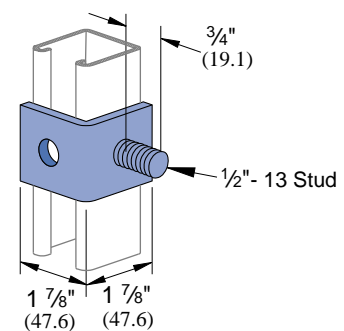

Wt/C 45 Lbs (20.4 kg)

Hole Size	Hole Spacing	Width	Thickness
5/16" Diameter 14.3 mm	1 3/16" (20.6 mm) From End 1 7/8" (47.6 mm) On Center	1 5/8" 41.3 mm	1/4" 6.4 mm

GENERAL FITTINGS

FOR 1⁵/₈" (41 MM) WIDTH SERIES CHANNEL



1⁵/₈" Channels

Nuts & Hardware

General Fittings

Pipe/Conduit Supports

Electrical Fittings

Concrete Inserts

1¹/₄" Framing System

1³/₁₆" Framing System

Spec. Metals & Fiberglass

Index

Page

Flat Plate Fittings	82
Ninety Degree Fittings	86
Angular Fittings	93
"Z" Shape Fittings	94
"U" Shape Fittings	96
Wing Shape Fittings	101
Post Bases	105
Brackets and Braces	106
Beam Clamps	112
Trolleys	122
Special Application Fittings	124
End Caps	126
Partition and Display Fittings	127



MATERIAL

Fittings, unless noted, are made from hot-rolled, pickled and oiled steel plates, strip or coil, and conform to ASTM specifications A575, A576, A635, or A36. The fitting steel also meets the physical requirements of ASTM A570 GR 33. The pickling of the steel produces a smooth surface free from scale.

Many fittings are also available in stainless steel, aluminum and fiberglass. Consult factory for ordering information.

FINISHES

Fittings are available in: Perma-Green II (GR), electro-galvanized

(EG), conforming to ASTM B633 Type III SC1; Hot-dipped galvanized (HG), conforming to ASTM A123 or A153 and plain (PL).

APPLICATION

All parts drawings illustrate only one application of each fitting. In most cases many other applications are possible. The channels shown in the illustrations are P1000, 1⁵/₈" square, except where noted otherwise. All ¹/₁₆" diameter holes use 1/2" x ¹⁵/₁₆" hex head cap screws and 1/2" nuts - P1010, P4010 or P5510 - depending on the channel used. Nuts and bolts are not included with the fitting and must be ordered separately.

DESIGN BOLT TORQUE

BOLT SIZE	1/4"	5/16"	3/8"	1/2"	5/8"	3/4"
FOOT LBS.	20	18	16	13	11	10
N·m	6	11	19	50	100	125

DIMENSIONS

Imperial dimensions are illustrated in inches. Metric dimensions are shown in parenthesis or as noted. Unless noted, all metric dimensions are in millimeters and rounded to one decimal place.

DESIGN LOAD

Design load data, where shown, is based on the ultimate strength of the connection with a safety factor of 2.5, unless otherwise noted.

DESIGN LOAD DATA

FOR 1 5/8" (41 MM) WIDTH SERIES CHANNEL



DESIGN LOAD DATA FOR TYPICAL UNISTRUT CHANNEL CONNECTIONS

90° Fittings (When used in position shown)										
Channel Thickness	P1026		P1026		P1325 P2235		P1458 P1579		P1346	
	Lbs	kN	Lbs	kN	Lbs	kN	Lbs	kN	Lbs	kN
12 ga.	1500	6.7	1000	4.4	2000	8.9	1500	6.7	2000	8.9
14 ga.	1000	4.4	650	2.9	2000	8.9	1000	4.4	1500	6.7
16 ga.	750	3.3	500	2.2	1500	6.7	1000	4.4	900	4.0

90° Fittings (When used in position shown)										Flat Plate Fittings
Channel Thickness	P2484		P1068		P1326		P1346		P1065	
	Lbs	kN	Lbs	kN	Lbs	kN	Lbs	kN	Lbs	kN
12 ga.	3000	13.3	500	2.2	500	2.2	1200	5.3	1000	4.4
14 ga.	2000	8.9	500	2.2	500	2.2	1200	5.3	800	3.6
16 ga.	1500	6.7	500	2.2	500	2.2	1000	4.4	600	2.7

Both ends of beams supported.

Load diagrams indicate up to three design loads, one for 12 gage sections (P1000), one for 14 gage sections (P1100), and one for 16 gage sections (P2000).

Load data is based on P1010 nut and 1/2" bolt.

Safety factor = 2 1/2 based on ultimate strength of connection.

1 5/8" Channels

Nuts & Hardware

General Fittings

Pipe/Conduit Supports

Electrical Fittings

Concrete Inserts

1 1/4" Framing System

1 3/16" Framing System

Spec. Metals & Fiberglass

Index