



## KT-PLED50-24-8XX-VDIM

### LED PANEL LIGHT

#### DESCRIPTION

2'x4' LED panel light, 50W family, 120-277V input, 0-10V dimming



#### PRODUCT FEATURES

- Low profile architectural grade design
- Fits standard T-grid ceilings
- Suitable for surface or suspension mount with optional accessories
- High quality laser etched PMMA resin light guide plate offers optimal light diffusion with no risk of yellowing over product lifetime
- Powered by Keystone 0-10V dimming LED driver with built-in junction box
- Compatible with Keystone SmartSafe emergency LED drivers; KT-EMRG-LED-5-500-EN /DF or KT-EMRG-LED-12-1200-EN /DF are optimal for fixture level installation; mounting kit KT-PLED-EM-BR-KIT required (sold separately)
- 60,000 hour rated life
- Over 50% energy savings as compared to traditional fluorescent troffers
- LED color binning within 4 SDCM ensures supreme color consistency between all panels
- Operating temperature range: -20°C/-4°F to 40°C/104°F
- Suitable for damp locations

#### PERFORMANCE SPECIFICATIONS

Catalog Number	Input Voltage	Wattage	Color Temperature	Lumen Output	CRI	Power Factor	Efficacy	Lifetime
KT-PLED50-24-835-VDIM	120-277V	50W	3500K	5,100	>81.6	>0.9	102 lm/W	60,000 Hours
KT-PLED50-24-840-VDIM	120-277V	50W	4000K	5,200	>81.6	>0.9	104 lm/W	60,000 Hours
KT-PLED50-24-850-VDIM	120-277V	50W	5000K	5,300	>81.6	>0.9	106 lm/W	60,000 Hours

#### PHOTOMETRIC SPECIFICATIONS

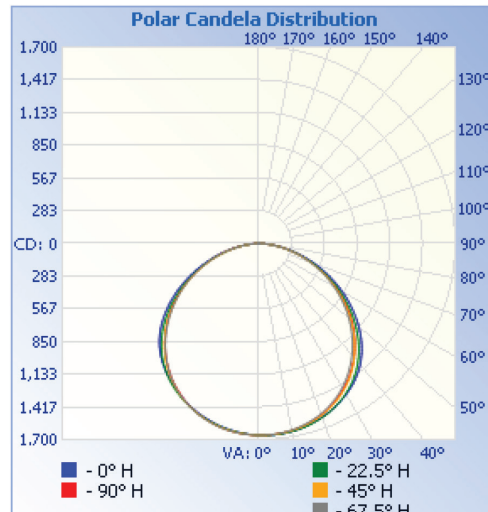
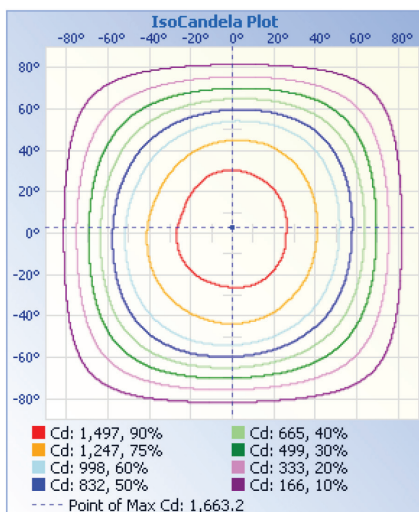

Zonal Lumen Summary		
Zone	Lumens	% Luminaire
0-30	1,316.6	26.1%
0-40	2,183.8	43.3%
0-60	3,940.9	78.1%
60-90	1,105.4	21.9%
70-100	467.4	9.3%
90-120	1.3	0%
0-90	5,046.3	99.9%
90-180	2.8	0.1%
0-180	5,049.1	100%



# KT-PLED50-24-8XX-VDIM

## LED PANEL LIGHT

### PHYSICAL SPECIFICATIONS

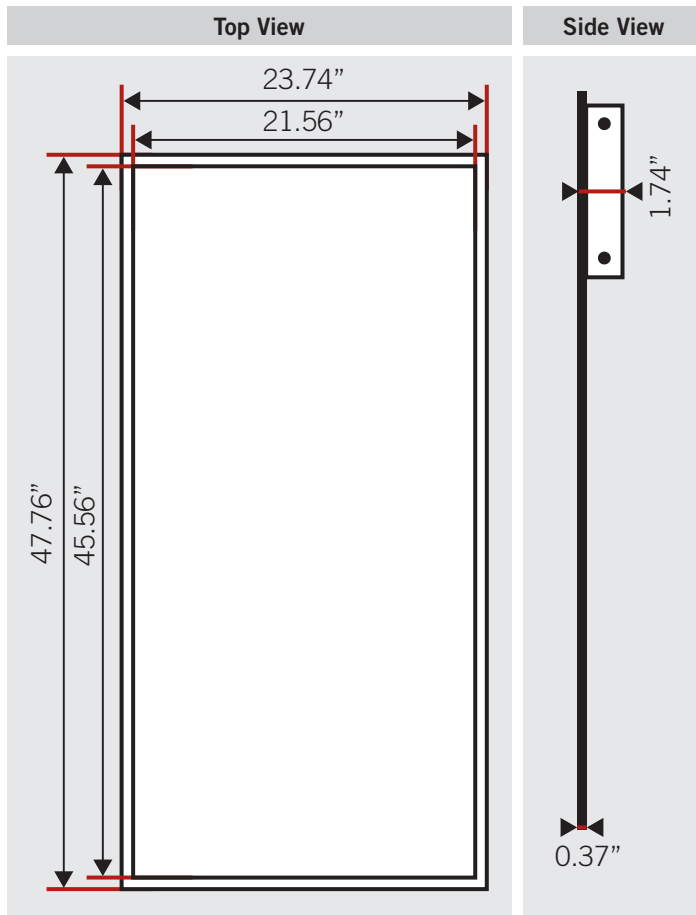

### WEIGHT INFORMATION

1 Piece	1 Carton
13.67 lbs	33.69 lbs

### ACCESSORIES (SOLD SEPARATELY)

Accessory	Catalog Number	Description
Cable Hanging Kit	KT-PLED-CABLE-KIT	Cable hanging kit for LED panel lights (includes 3 cable sets)
Surface Mount Kit	KT-PLED-SM-24-KIT	Surface mount kit for (1) 2x4 LED panel light
SmartSafe Emergency Battery Backup	KT-EMRG-LED-5-500-EN /DF	5W, 500 lumen SmartSafe emergency battery back-up with dual flex cables
	KT-EMRG-LED-12-1200-EN /DF	12W, 1200 lumen SmartSafe emergency battery back-up with dual flex cables for remote mounting only
Emergency LED Backup Mounting Kit	KT-PLED-EM-BR-KIT	Bracket kit for mounting emergency LED backup to LED panel lights; designed for use with KT-EMRG-LED-5-500-EN /DF and KT-EMRG-LED-12-1200-EN /DF

### CATALOG NUMBER BREAKDOWN

# KT-PLED50-24-8XX-VDIM

1 2 3 4 5 6 7

- 1 Keystone Technologies
- 2 Panel Light LED Fixture
- 3 Wattage
- 4 2' x 4' Nominal Size
- 5 800 Series
- 6 Color Temperature
- 7 0-10V Dimming



## KT-PLED50-24-8XX-VDIM

### LED PANEL LIGHT

#### DESCRIPTION

2'x4' LED panel light, 50W family, 120-277V input, 0-10V dimming



#### PRODUCT FEATURES

- Low profile architectural grade design
- Fits standard T-grid ceilings
- Suitable for surface or suspension mount with optional accessories
- High quality laser etched PMMA resin light guide plate offers optimal light diffusion with no risk of yellowing over product lifetime
- Powered by Keystone 0-10V dimming LED driver with built-in junction box
- Compatible with Keystone SmartSafe emergency LED drivers; KT-EMRG-LED-5-500-EN /DF or KT-EMRG-LED-12-1200-EN /DF are optimal for fixture level installation; mounting kit KT-PLED-EM-BR-KIT required (sold separately)
- 60,000 hour rated life
- Over 50% energy savings as compared to traditional fluorescent troffers
- LED color binning within 4 SDCM ensures supreme color consistency between all panels
- Operating temperature range: -20°C/-4°F to 40°C/104°F
- Suitable for damp locations

#### PERFORMANCE SPECIFICATIONS

Catalog Number	Input Voltage	Wattage	Color Temperature	Lumen Output	CRI	Power Factor	Efficacy	Lifetime
KT-PLED50-24-835-VDIM	120-277V	50W	3500K	5,100	>81.6	>0.9	102 lm/W	60,000 Hours
KT-PLED50-24-840-VDIM	120-277V	50W	4000K	5,200	>81.6	>0.9	104 lm/W	60,000 Hours
KT-PLED50-24-850-VDIM	120-277V	50W	5000K	5,300	>81.6	>0.9	106 lm/W	60,000 Hours

#### PHOTOMETRIC SPECIFICATIONS

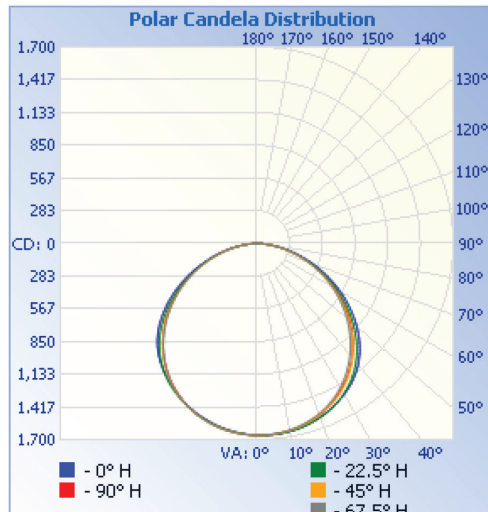
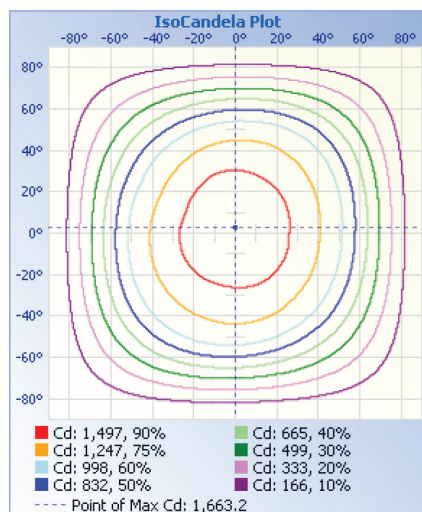

Zonal Lumen Summary		
Zone	Lumens	% Luminaire
0-30	1,316.6	26.1%
0-40	2,183.8	43.3%
0-60	3,940.9	78.1%
60-90	1,105.4	21.9%
70-100	467.4	9.3%
90-120	1.3	0%
0-90	5,046.3	99.9%
90-180	2.8	0.1%
0-180	5,049.1	100%



# KT-PLED50-24-8XX-VDIM

## LED PANEL LIGHT

### PHYSICAL SPECIFICATIONS

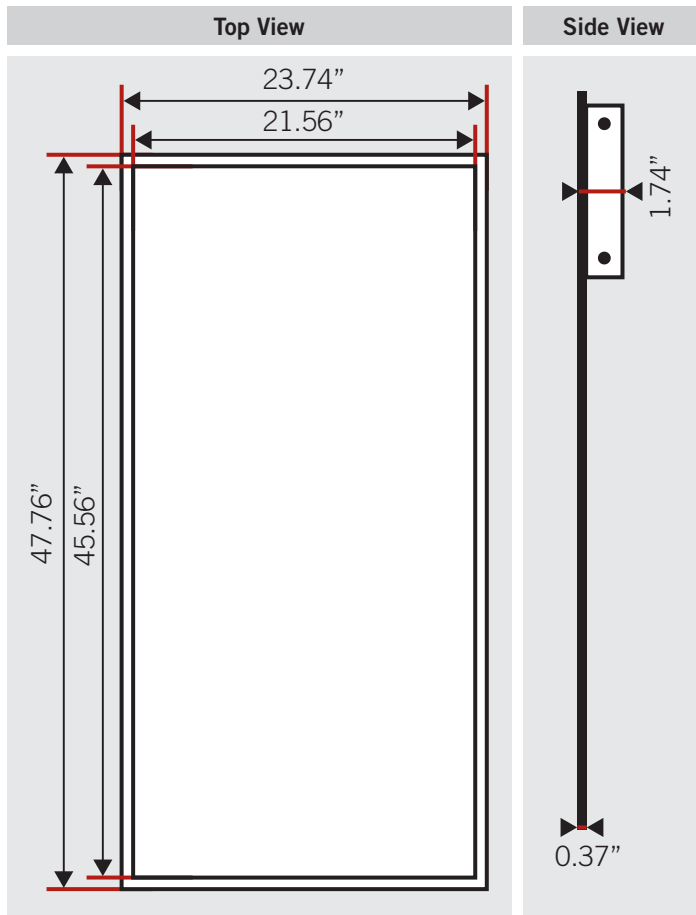

### WEIGHT INFORMATION

1 Piece	1 Carton
13.67 lbs	33.69 lbs

### ACCESSORIES (SOLD SEPARATELY)

Accessory	Catalog Number	Description
Cable Hanging Kit	KT-PLED-CABLE-KIT	Cable hanging kit for LED panel lights (includes 3 cable sets)
Surface Mount Kit	KT-PLED-SM-24-KIT	Surface mount kit for (1) 2x4 LED panel light
SmartSafe Emergency Battery Backup	KT-EMRG-LED-5-500-EN /DF	5W, 500 lumen SmartSafe emergency battery back-up with dual flex cables
	KT-EMRG-LED-12-1200-EN /DF	12W, 1200 lumen SmartSafe emergency battery back-up with dual flex cables for remote mounting only
Emergency LED Backup Mounting Kit	KT-PLED-EM-BR-KIT	Bracket kit for mounting emergency LED backup to LED panel lights; designed for use with KT-EMRG-LED-5-500-EN /DF and KT-EMRG-LED-12-1200-EN /DF

### CATALOG NUMBER BREAKDOWN

# KT-PLED50-24-8XX-VDIM

1      2      3      4      5      6      7

- |                           |                     |
|---------------------------|---------------------|
| 1 Keystone Technologies   | 5 800 Series        |
| 2 Panel Light LED Fixture | 6 Color Temperature |
| 3 Wattage                 | 7 0-10V Dimming     |
| 4 2' x 4' Nominal Size    |                     |