

PVC Coated Elbows

Catalog Number: PRHELB-1-1/2X90

UPC: 784011200320

Description

1-1/2X90 PVC Coated Standard Elbow

Factory-bent PVC coated elbows are more accurate, quicker to install and more economical because they eliminate field bending time and waste of material. Electrical continuity is maintained across assembled joints.

Application

- Factory-bent for accurate, quicker to install and eliminates costly field bending and waste of material
- Factory-bent for accurate, quicker to install and eliminates costly field bending and waste of material

Features

- 40 mil gray PVC exterior coating
- 2 mil red urethane interior coating
- 12 trade sizes from 1/2" through 6"
- Available in standard sizes 90°, 60°, 45°, 30° bends
- Color-coded thread protector caps for quick identification of conduit size

General

Material:	STEEL
Exterior Finish:	A nominal .040 inch (40 mil) gray PVC coating
Interior Finish:	A nominal .002 inch (2 mil) red urethane
Thread Finish:	A red urethane coating over steel
Thread Protector Color:	Black

Dimensions

Metric Size Designators	41
Nipple Length (Inches)	19-3/4
Diameter - External (Inches)	1.98
Diameter - Internal (Inches)	1.624
Radius A (Inches)	7.26
Radius B - Standard (Inches)	8.25
Radius C (Inches)	9.24
Offset D (Inches)	10.635
Offset E (Inches)	11.625
Offset F (Inches)	12.615
Tangent (Inches)	3.375

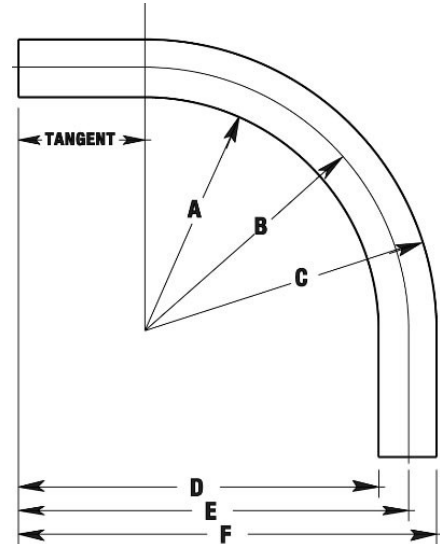



PVC Coated Elbows

Catalog Number: PRHELB-1-1/2X90

UPC: 784011200320

Technical / Specification Documents

Specification Guide (1995 Master) *AVAILABLE ON WEBSITE*

Specification Guide (2004 Master) *AVAILABLE ON WEBSITE*

Installer Certification and Tools *AVAILABLE ON WEBSITE*

Chemical Resistance Charts *AVAILABLE ON WEBSITE*

Performance Specifications *AVAILABLE ON WEBSITE*

Standards

UL 6: E2314

CSA Certified: C22.2 No. 45

Notes

Both PVC and zinc coatings have been investigated as primary protection against corrosion.

Restricted for use with threaded fittings only.



PVC Coated Elbows

Catalog Number: PRHELB-1-1/2X90

UPC: 784011200320

Description

1-1/2X90 PVC Coated Standard Elbow

Factory-bent PVC coated elbows are more accurate, quicker to install and more economical because they eliminate field bending time and waste of material. Electrical continuity is maintained across assembled joints.

Application

- Factory-bent for accurate, quicker to install and eliminates costly field bending and waste of material
- Factory-bent for accurate, quicker to install and eliminates costly field bending and waste of material

Features

- 40 mil gray PVC exterior coating
- 2 mil red urethane interior coating
- 12 trade sizes from 1/2" through 6"
- Available in standard sizes 90°, 60°, 45°, 30° bends
- Color-coded thread protector caps for quick identification of conduit size

General

Material:	STEEL
Exterior Finish:	A nominal .040 inch (40 mil) gray PVC coating
Interior Finish:	A nominal .002 inch (2 mil) red urethane
Thread Finish:	A red urethane coating over steel
Thread Protector Color:	Black

Dimensions

Metric Size Designators	41
Nipple Length (Inches)	19-3/4
Diameter - External (Inches)	1.98
Diameter - Internal (Inches)	1.624
Radius A (Inches)	7.26
Radius B - Standard (Inches)	8.25
Radius C (Inches)	9.24
Offset D (Inches)	10.635
Offset E (Inches)	11.625
Offset F (Inches)	12.615
Tangent (Inches)	3.375

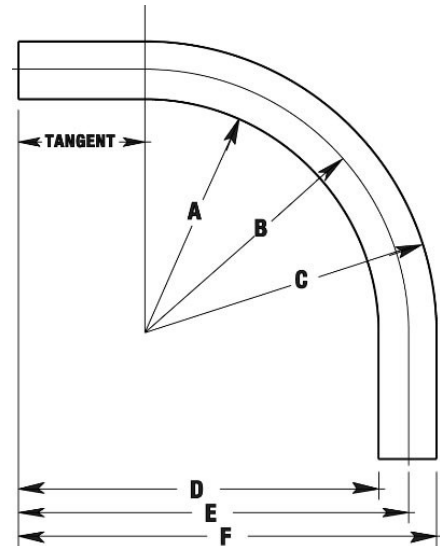



PVC Coated Elbows

Catalog Number: PRHELB-1-1/2X90

UPC: 784011200320

Technical / Specification Documents

Specification Guide (1995 Master) *AVAILABLE ON WEBSITE*

Specification Guide (2004 Master) *AVAILABLE ON WEBSITE*

Installer Certification and Tools *AVAILABLE ON WEBSITE*

Chemical Resistance Charts *AVAILABLE ON WEBSITE*

Performance Specifications *AVAILABLE ON WEBSITE*

Standards

UL 6: E2314

CSA Certified: C22.2 No. 45

Notes

Both PVC and zinc coatings have been investigated as primary protection against corrosion.

Restricted for use with threaded fittings only.

