

Model with Type 1 Steel Enclosure	Clock Motor VAC 60 Hz	Skipper Wheel
T1905HD	125	No
T1975EHD	480	Yes

Specifications

The time switch shall be of the 24-Hour type dial and shall include 96 permanently attached trippers. The time switch shall provide up to 48 ON and 48 OFF periods of 15 minutes each per day. The time switch shall be powered by a _____ (125)(480) Volt 60 Hz synchronous motor. The synchronous motor shall be designed to prevent damage caused by voltage transients up to 6000 Volts minimum. The time switch motor shall be connected to the supply terminals with ring-type connectors and shall not require more than 3 Watts to operate time switch. An omitting device _____ (shall)(shall not) be required to enable switching operation to be skipped for any pre-selected day(s) of the week. The time switch shall have a snap-in mechanism to allow easy removal from the time switch enclosure. The enclosure shall be a steel UL Type 1 with lockable hasp. The enclosure shall provide a minimum of 31 cubic inches of wiring space and provide a non-removable cover, which shall open a full 180 degrees. The time switch shall provide clear terminal identification on a non-curling terminal insulator. The time switch contacts shall be SPDT and rated at 20 Amps per pole. The time switch shall be agency listed under Clock Operated Switches and shall be Intermatic model _____ (See Model Numbers Listed).

Diagrams

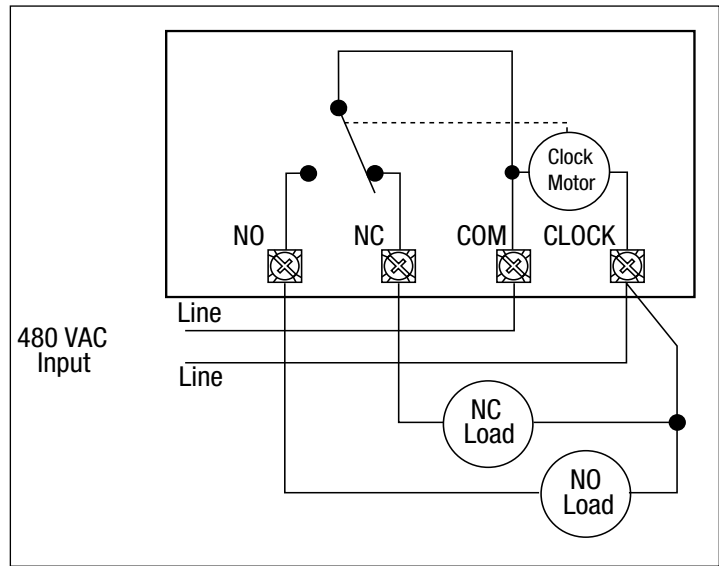
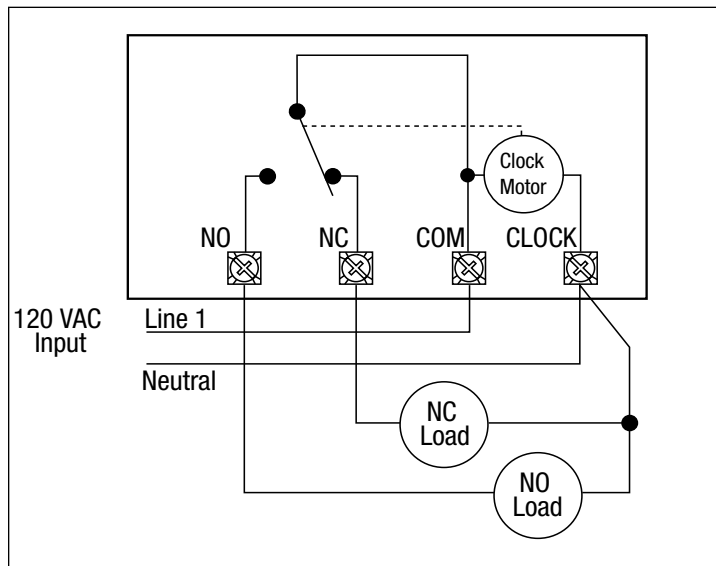

T1900HD Series

Heavy-Duty Time Switch

The T1900HD Series Mechanical Time Switches are heavy-duty, all steel construction 24-Hour time controls, designed for long life under extreme conditions. They provide precise timing in 15-Minute increments and repeat the program in 24 hours. Models with the Skip-a-Day feature enable operation to be selected as desired for each day of the week. All models have a permanent ON lever (if wired as normally open) to override program without disturbing the pre-set schedule. The time switch has 96 permanently attached brass trippers that tilt in and out and are easily set by hand.

Features

- Minimum ON/OFF time is 15 minutes
- Trippers permanently attached, tilt in/out
- Skip-a-Day feature
- Permanent manual ON/OFF lever
- Heavy-duty, synchronous clock motor
- Adjustable duty cycles of 1/2, 3, 4, 6, 12 & 24-Hours

Ratings

Enclosure Type:	Type 1
Knockouts:	Combination 1/2" - 3/4" nominal knockouts, one on back and on each side, and two on bottom
Switch Type:	Single Pole Double Throw
Switch Rating:	20 Amp maximum 125, 208-277 and 480 VAC, 1/2 HP, 125 VAC 1 HP, 250 VAC
Power Input:	3 Watts maximum
Operating Temp:	-40°F to 165°F (-40°C to 74°C)
Shipping Weight:	3.5 lbs. (1.6 kg)
Warranty:	1 year

Project: _____

Location: _____

Product Type: _____

Contact/Phone: _____

Model #: _____



Model with Type 1 Steel Enclosure	Clock Motor VAC 60 Hz	Skipper Wheel
T1905HD	125	No
T1975EHD	480	Yes

Specifications

The time switch shall be of the 24-Hour type dial and shall include 96 permanently attached trippers. The time switch shall provide up to 48 ON and 48 OFF periods of 15 minutes each per day. The time switch shall be powered by a _____ (125)(480) Volt 60 Hz synchronous motor. The synchronous motor shall be designed to prevent damage caused by voltage transients up to 6000 Volts minimum. The time switch motor shall be connected to the supply terminals with ring-type connectors and shall not require more than 3 Watts to operate time switch. An omitting device _____ (shall)(shall not) be required to enable switching operation to be skipped for any pre-selected day(s) of the week. The time switch shall have a snap-in mechanism to allow easy removal from the time switch enclosure. The enclosure shall be a steel UL Type 1 with lockable hasp. The enclosure shall provide a minimum of 31 cubic inches of wiring space and provide a non-removable cover, which shall open a full 180 degrees. The time switch shall provide clear terminal identification on a non-curling terminal insulator. The time switch contacts shall be SPDT and rated at 20 Amps per pole. The time switch shall be agency listed under Clock Operated Switches and shall be Intermatic model _____ (See Model Numbers Listed).

Diagrams

