

Thermal overload relays

T7DU, TA25DU, TA42DU, TA75DU, TA80DU, TA110DU, TA200DU, TA450DU

Class 10

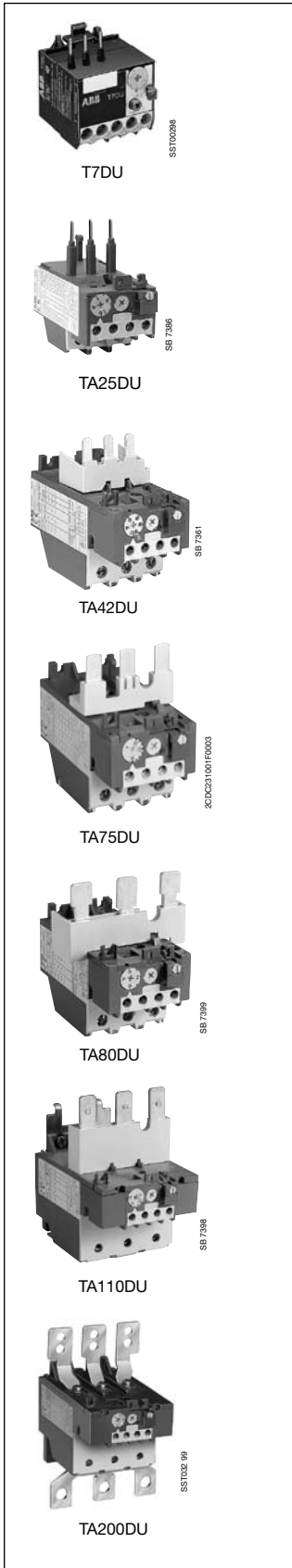

Normal starting time class 10:

For contactors	Setting range A	Catalog number	List price
Mini contactors B7-BC7	0.1 ... 0.16	T7DU0.16	
	0.16 ... 0.24	T7DU0.24	
	0.24 ... 0.4	T7DU0.4	
	0.4 ... 0.6	T7DU0.6	
	0.6 ... 1	T7DU01.0	
	1 ... 1.6	T7DU1.6	
	1.6 ... 2.4	T7DU2.4	
	2.4 ... 4	T7DU4.0	
	4 ... 6	T7DU6.0	
	6 ... 9	T7DU9.0	
	9 ... 12	T7DU12.0	
	A/AL/TAL9...40	0.1 ... 0.16	TA25DU0.16
0.16 ... 0.25		TA25DU0.25	
0.25 ... 0.4		TA25DU0.4	
0.4 ... 0.63		TA25DU0.63	
0.63 ... 1		TA25DU1.0	
1 ... 1.4		TA25DU1.4	
1.3 ... 1.8		TA25DU1.8	
1.7 ... 2.4		TA25DU2.4	
2.2 ... 3.1		TA25DU3.1	
2.8 ... 4		TA25DU4.0	
3.5 ... 5		TA25DU5.0	
4.5 ... 6.5		TA25DU6.5	
6 ... 8.5		TA25DU8.5	
7.5 ... 11		TA25DU11	
10 ... 14		TA25DU14	
A/AL/TAL30...40	13 ... 19	TA25DU19	
	18 ... 25	TA25DU25	
	24 ... 32 ⁽¹⁾	TA25DU32	
	18 ... 25	TA42DU25	
AF50...75	22 ... 32	TA42DU32	
	29 ... 42	TA42DU42	
	18 ... 25	TA75DU25	
	22 ... 32	TA75DU32	
	29 ... 42	TA75DU42	
	36 ... 52	TA75DU52	
A/AF95...110	45 ... 63	TA75DU63	
	60 ... 80	TA75DU80	
	29 ... 42	TA80DU42	
	36 ... 52	TA80DU52	
A/AF95...110	45 ... 63	TA80DU63	
	60 ... 80	TA80DU80	
	66 ... 90	TA110DU90	
A/AF145-A/AF185	80 ... 110	TA110DU110	
	66 ... 90	TA200DU90	
	80 ... 110	TA200DU110	
	100 ... 135	TA200DU135	
	110 ... 150	TA200DU150	
	130 ... 175	TA200DU175	
A/AF210-A/AF300	150 ... 200	TA200DU200	
	130 ... 185	TA450DU185	
	165 ... 235	TA450DU235	
	220 ... 310	TA450DU310	

(1) With terminal block DX25: 1 x 16 mm²

Thermal overload relays T...

Description

Intermittent periodic duty

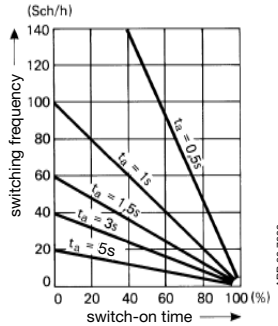

Switching frequency depending on duty ratio ED in %, t_a : Motor starting time

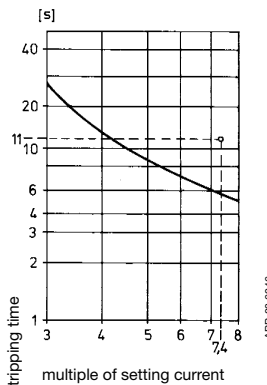

Tripping curve of overload relay T .. starting from cold state

- **Switching frequency**

Thermal overload relays T cannot be operated at any arbitrary switching frequency in order to avoid tripping. Applications involving up to 15 operations per hour are acceptable. Higher switching frequencies are permitted if the duty ratio and the motor starting time are allowed for and if the motor's making current does not appreciably exceed 6 times the rated operating current. Please refer to the adjacent diagram for guideline values for the permitted switching frequency.

Example: Starting time of the motor: 1 second

Duty ratio: 40 %

means a permitted switching frequency of max. 60 operations per hour

Use of the CUSTORAPID® motor protection is recommended for higher switching frequencies and alternating loading, e.g. for frequent starting and braking. Use of a combination of thermal overload relays and CUSTORAPID® is recommended in the case of locked rotors on motors with thermally critical rotors.

- **Protection with heavy starting**

Relays **TA450SU** can be used for particularly severe starting conditions. The setting ranges specified on Pages 41 and 42 apply to non-recurrent looping through of the cables. The relay may also be used for lower motor rated currents. This is achieved by looping the cables through several times. The setting range specified on the rating plate is inversely proportional to the number of cables looped through. For instance: TA450DU/SU with a setting range of 130 ... 185 A is also suitable for currents of 65 ... 92.5 A if the cables are looped through twice; the figures are 43.3 ... 61.6 A for looping the cables through three times.

- **Special version for EEx e motors**

Relays T7DU, TA25DU ... TA450DU/SU are suitable for protection of EEx e motors. They have been tested and approved by the "German National Standards Laboratory" (PTB) in Braunschweig, Germany.

When selecting the overload relay, check suitability on the basis of the tripping curves. The values for the ratio of pick-up current I_a to rated current I_n and the shortest t_E time are crucial, and these must be specified on the PTB Approval Certificate and on the motor's rating plate. The relay must trip within the t_E time, i.e. the tripping curve, starting from cold state, must run below the coordinate point I_a/I_n and the t_E time.

- **Example for suitability of an overload relay T/TA:**

The motor with increased safety has the following data:

Output = 7.5 kW, $I_a/I_n = 7.4$ t_E time = 11 seconds.

In accordance with the adjacent tripping curve, the tripping time lies below the t_E time of the motor. The special relay version for EEx e motors differs from the normal version as follows:

- **Special test of the tripping times at the works**

- **Special order code**

Tripping curves for the individual setting ranges and the PTB Approvals Certificates may be ordered.

Limit values for tripping at ambient temperatures other than 20 °C

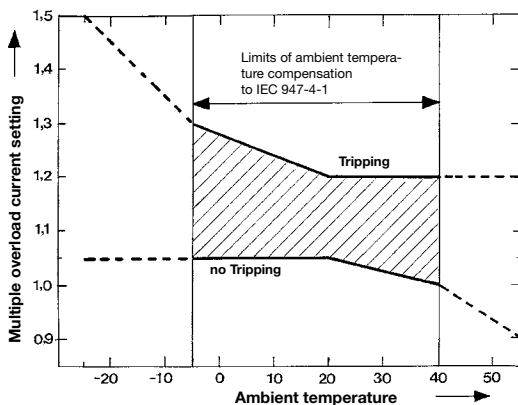

- **Ambient temperature compensation :**

The overload relays are protected against influences of ambient temperature by a bimetallic compensation element which detects the ambient temperature. This design means that tripping occurs between -5 °C and +40 °C within the ranges defined by IEC 947-4-1. See the adjacent curve for the extended range of -25 °C resp. +55 °C.

- **Example :**

Tripping at -25 °C. Tripping occurs at ≤ 1.5 times the setting current.

- **Reset :**

Types E16DU, T7DU, TA25DU ... TA450DU/SU feature a convertible Manual/ Automatic reset.

- **Condition as delivered :**

Manual reset.

Thermal overload relays T...

Technical data

General technical data

Type	T7DU	TA25DU	TA42DU	TA75DU
Standards: (major international European and national standards)	IEC 947-4-1, VDE 0660, NFC 63 650, BS 4941, EN 60947-4-1 CSA22.2 No. 14, UL508			
Approvals, certificates	see page 5/15			
Rated insulation voltage U_i to IEC 158-1, IEC 947-4-1	V	690	660/690	
Impulse withstand voltage U_{imp} to IEC 947-4-1	kV	6	6	
Permissible ambient temperature – Storage temperature	°C	– 40 to +70		
– for operation (compensated)	°C	– 25 to +55		
Climatic resistance to DIN 50017	Resistant to changeable climate KFW, 30 cycles			
Mounting position	any, but please avoid vertical mounting position wherever possible			
Resistance to shock at rated current I _n , A1	shock duration ms	10	15	
• critical shock direction A1, A2	multiple of g	10	12	
Resistance to vibration: (±1 mm, 50 Hz)	multiple of g	4	8	
Mounting – onto contactor – with AB.. mounting kit	hooking beneath the contactor, screwing on its main terminals by screws: 2 x M4 or  35 mm EN 50022			
Connection terminals and attachment type Main conductors (motor side)	TA25DU setting ranges: 0.1...0.16 A24...32 A to 18...25 A			
• Screw terminals – Screw terminal – with terminal block – with busbars or cable lugs	M3.5	M4	– M5	M6
• Connection cross-sections – single-core or stranded – flexible with wire end ferrule – busbars	AWG 2 x 18... 14 AWG 2 x 18... 14 AWG –	2 x 16... 10 2 x 16... 10 –	2 x 16... 10 2 x 16... 10 –	1 x 14 ... 4 or 2 x 14 ... 6 1 x 14 ... 4 or 2 x 14 ... 8 –
Connections and auxiliary connectors • Screw terminal (screw size) – with self-disengaging clamping piece	M 3.5			
• Connection cross-section – single-core or stranded – flexible with wire end ferrule	AWG 2 x 18... 14 AWG 2 x 18... 14	2 x 18... 14 2 x 18... 14		
Enclosure to IEC 144, IEC 529	All terminals are safe from finger-touch and safe from touch by the back of the hand to VDE 0106, Part 100 (no extra terminal shrouds are required up to and including TA110DU)			

Technical data of the conducting paths

Type	T7DU	TA25DU	TA42DU	TA75DU	TA80DU	TA110DU	TA200DU	TA450DU	TA450SU
Number of paths	3								
Setting ranges	see ordering details								
Tripping class to IEC 947-4-1 / VDE 0660, Part 1021	10-20			10			30		
Frequency range Hz	0 ... 400						50/60		
Switching frequency without early tripping	up to 15 ops./h or 60 ops./h with 40 % if the breaking current does not exceed 6 x I _n and the starting time does not exceed 1 s								

Thermal overload relays T...

Technical data

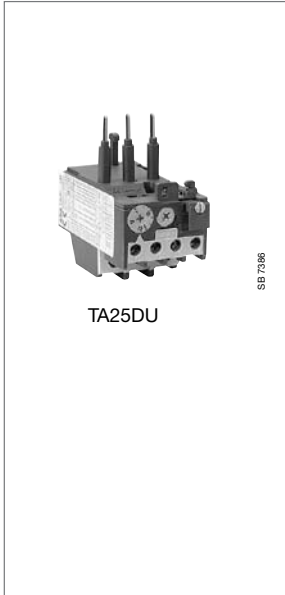

Load rating of auxiliary contacts

Type	T7DU		TA25DU ...TA450DU/SU	
	NC 95 - 96	NO 97-98	NC 95 - 96	NO 97 - 98
Auxiliary switch				
Rated operating voltage U_e	500			
Rated thermal current I_{th}	6	6	10	6
Rated operating current I_e				
at AC 15 to 240 V	1.5	1.5	3	1.5
at AC 15 to 440 V	0.7	0.5	1.9	0.95
at AC 15 to 500 V	0.5	0.3	1	0.75
at DC 13 to 24 V	-	-	1.25	0.42
to 60 V	-	-	0.50	0.17
to 120 V	-	-	0.25	0.08
to 250 V	0.2	0.02	0.12	0.04
Maximum potential difference between the NO and NC contacts	AC V 500 DC V 440		500 440	
Short-circuit protection	4	4	10	6
STOTZ circuit-breaker type:				
S271	A	K1	K3	K1
S281	A	K1	K3	K1

Function of the thermal overload relays

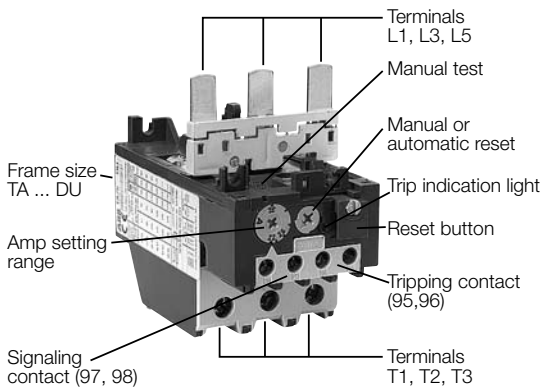

Press blue button	Contacts	Relay tripped		Relay not tripped	
		Manual	Automatic	Manual	Automatic
	NC 95-96 NO 97-98	open closed	open closed	closed open	closed open
Button R	NC 95-96 NO 97-98	Reset closes when Button's pressed	- -	- -	- -
Button R/O	NC 95-96 NO 97-98	Reset closes when Button's released	- -	- opens when Button's pressed closes when Button's released	- opens when Button's pressed closes when Button's released

Position of the connection terminals

TA25DU, TA42DU,
TA75DU, TA80DU

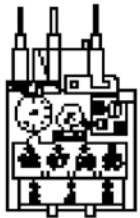

TA200DU

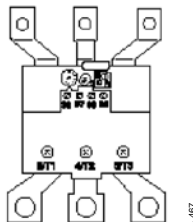

TA450DU/SU

