

CATALOG NUMBER	STRANDED COPPER CONDUCTOR ACCOMMODATED			BOLT SIZE	METRIC BOLT SIZE	DIMENSIONS							
	CODE (AWG)	NAVY	METRIC SIZE (CLASS 2)			B	C	K DIA.	L	N	O.D.	T REF.	Z MIN.
YA3CL	#3 AWG #2 SOL	50	25mm ² STR [6.6]	5/16	M8	.88 [22]	.55 [14]	.33 [8]	1.88 [48]	.34 [9]	.38 [10]	.09 [2]	.36 [9]
YA3CL4		60		3/8	M10		.58 [15]	.41 [10]	2.05 [52]	.41 [10]	.38 [10]	.08 [2]	.42 [11]
YA3CL6		50		1/2	M12		.73 [19]	.53 [13]	2.30 [58]	.53 [13]	.38 [10]	.07 [2]	.55 [14]
YA2CL2	#2 AWG	60	-----	1/4	M6		.61 [15]	.27 [7]	1.88 [48]	.31 [8]	.42 [11]	.11 [3]	.33 [8]
YA2CL2U				---	---		---	.60 [15]	---	1.77 [45]	---	.42 [11]	.11 [3]
YA2CL				5/16	M8	.61 [15]	.33 [8]	1.93 [49]	.34 [9]	.42 [11]	.11 [3]	.36 [9]	

CONNECTOR SIZE	TOLERANCES					
	B	C	K DIA.	L	N	O.D.
-8C THRU -25	±.06	±.04	±.02	±.09	±.03	±.01
-26 THRU -34	±.08	±.04	±.02	±.12	±.03	±.01
-35 AND UP	±.09	±.06	±.02	±.15	±.06	±.01

TOLERANCE BLOCK

CATALOG NO.	COLOR CODE	DIE INFORMATION		MECHANICAL				HYDRAULIC				DIELESS (# CRIMPS)	WIRE STRIP LENGTH			
		DIE INDEX	TYPE	YIMRTC	OUR840	MD6 MD7	MD6--R2 MD7-34R	Y500CT PATMD6 PAT600	Y34A Y34B Y34BH	Y35, Y39, Y750, BAT35 PAT750	Y46 PAT46			Y45	Y48B	Y60BHU
YA3CL YA3CL4 YA3CL6	WHITE	9	WHITE DIE SET	WHITE (2)	W3CRT (1)	W3CRT (1)	W3CRT (1)	W3CRT (1)	-----	U3CRT(1)	U3CRT(1)	U3CRT(1)	---	---	MECHANICAL: MY29-3 (1) MY29-11(1) HYDRAULIC: Y644 (1) Y81KFT (1) Y4PC834 (1)	15/16"
YA2CL2 YA2CL2U YA2CL	BROWN	10	BROWN DIE SET	BROWN(2)	X2CRT(1)	X2CRT(2) W2CRT(1) W2CVT(1)	X2CRT(2) W2CRT(1) W2CVT(1)	X2CRT(1) W2CRT(1) W2CVT(1)	-----	U2CRT(1)	U2CRT(1)	U2CRT(1)	---	---	MECHANICAL: MY29-3 (1) MY29-11(1) MRC840 (1) HYDRAULIC: Y644 (1) Y81KFT (1) Y4PC834 (1)	15/16"

NOTES:

- MATERIAL: COPPER TUBING.
- FINISH: ELECTRO-TIN PLATED.
- CATALOG # PT6515 ADAPTOR IS REQUIRED TO USE "U" DIES IN Y45 SERIES TOOLS.
- CATALOG # PUADP-1 ADAPTOR IS REQUIRED TO USE "U" DIES IN Y46 SERIES TOOLS.
- Y35P3 INDENTOR ADAPTOR REQUIRED FOR Y34PR INDENTOR.
- PERMANENT DIE IN TOOLING.
- DIMENSIONS IN BRACKETS [] ARE IN MILLIMETERS ROUNDED OFF TO THE NEAREST MILLIMETER, UNLESS OTHERWISE NOTED, AND ARE FOR REFERENCE ONLY.
- FOR USE BY CUSTOMERS THAT HAVE THIS HYPRESS™. NO NEW Y34A HYPRESS™ TOOLS ARE BEING PROCESSED. Y34A USES A--D NEST DIES ONLY.
- CONNECTORS ARE UL LISTED; UNDRILLED VERSIONS ARE NOT UL LISTED.
- CONNECTORS ARE CSA CERTIFIED. UNDRILLED VERSIONS ARE NOT CSA CERTIFIED.
- FOR UNDRILLED VERSIONS ADD SUFFIX "-U" TO END OF CATALOG NUMBER. FOR UNDRILLED VERSIONS, USE D MIN. = N MAX. + Z MIN.
- "X", "W-RT", "W-VT", "U" & "L" DIE SETS ARE COLOR CODED. "A", "B" AND "C" DIES ARE NOT COLOR CODED. NESTS AND INDENTOR TYPE ARE NOT COLOR CODED.

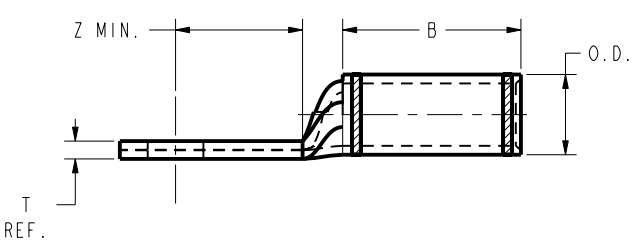
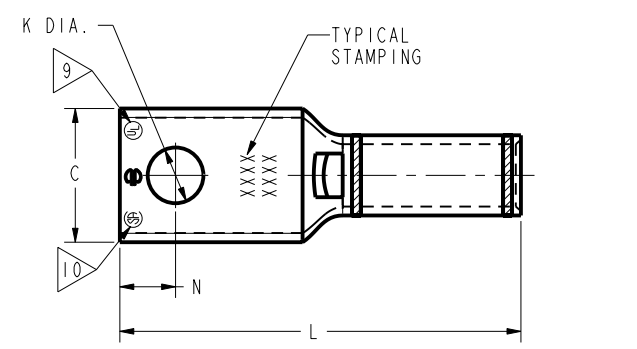

REFERENCE: SE209240

TO ORDER BURNDY® PRODUCTS CALL		HYLUG™ COPPER	
UNITED STATES 1-800-346-4175 (LONDONDERRY, NH)		ITEM NO: N/A	CAT. NO: YA-C-L- (TABLE)
CANADA: 1-800-361-6975 (QUEBEC) 1-800-387-6487 (ALL OTHER PROVINCES)		DRAWN BY: C.RACCANO 6/16/77	CHECKER: CAR 6/16/77
FOR PRODUCT INFO: http://www.burndy.com		DSN APPVL: LB 6/24/77	MFG APPVL: N/A N/A
		QA APPVL: C.ACKERMAN 9/30/94	MKT APPVL: T.NELSON 9/07/94
		PROJ #:	SCALE: 1:1
		SIZE: D	DRAWING NO: SD079848
		DOCUMENT TYPE: Sales	REV: E
		REL LEVEL: Released	SHEET 5 OF 17

REV: PE0200