

PHOTOCONTROLS

Electronic Instant Response Turn-Lock

LED Photocontrol Long Life

ZTL Series



ZTL124F
(FAIL OFF)

APPLICATIONS

- Designed meet local utility standards for street and highway lighting controls.
- All LED, CFL, Induction, HPS, MH and HID lighting fixtures requiring instant response dusk-to-dawn control.
- Ideal for roadway, area, parking, flood and security type lighting fixtures.

FEATURES

- **Zero-Cross (LED):** The ZTL Series Photoclock is microprocessor controlled with enhanced ZERO-CROSS Switching Technology allowing it to withstand the high inrush currents commonly found in all LED Luminaires.
- **Long Life:** Backed by a 15-Year Warranty, all electrical components are to exceed 15,000 ON/OFF operations and the 20 year long-life requirements needed for today's LED luminaires.
- **Light Sensor:** Superior light sensing technology driven by a molded sealed IR Filtered Non-Drifting Silicon Sensor designed for extreme accuracy and calibrated to duplicate a Human Eye Response.
- **Surge Protection:** Enhanced 510 Joule MOV component helps provide superior Photoclock and LED luminaire surge protection against unpredictable line voltage spikes.
- **Relay:** UL Listed industrial strength DC relay with positive snap action technology virtually eliminating bounce and ensuring a secure contact at each switch cycle.
- **Weather:** UV stabilized Polycarbonate housing and window with conformal coated electronics maximizing protection against extreme weather elements and moisture.
- **Safety:** Tested and certified to meet both UL and CSA Photoclock standards and the most current ANSI C136.10-2010 American National Standard for Roadway and Area Lighting Equipment.
- **Operation:** Delayed OFF response prevents false switching due to light from vehicles or lighting, etc.
- **Energy Savings:** Rated for use with LED lamp drivers.
- **Custom:** Customize your special order by choosing multiple colors, Turn-On light trigger levels, special packaging or superior surge protection magnitude to meet your specific job requirement.
- **ZTL124F**
 - **Fail OFF:** Protects LED drivers from daytime operation where additional daytime heat gain degrades electronic drivers.

SPECIFICATIONS

- **ON/OFF:** Turn-ON is 1.5 foot candle +/-0.2 OFF/ON ratio is 1.5:1 average.
- **Time Delay:** Instant ON/3 seconds OFF.
- **Cell:** Molded sealed IR filtered sensor.
- **Relay:** Rated life 15,000 operations.
- **Surge Protection:** 510 joules MOV (Metal oxide varistor) exceeds ANSI and NEMA requirements.
- **Locking Prongs:** Solid brass for maximum corrosion resistance and electrical conductivity.
- **Custom:** Available for custom design to meet specific utility specification.
- **Temperature Range:** -40 °F to +140 °F (-40 °C to +60 °C).
- **Fail Mode:** ON.
- **Tungsten/Ballast:** 1000W/1800VA.
- **Electronic Ballast/LED:** 8A or totaling 2220W@277VAC.
- **Limited Warranty:** 15 years.

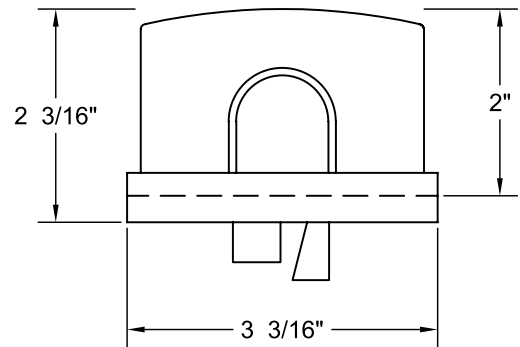

CAT. NO.	CERTIFICATION	UPC CODE	VOLTAGE VAC 50/60Hz	COLOR	MOV	RATING		
						TUNGSTEN	BALLAST	ELECTRONIC BALLAST (LED)
ZTL124	cULus	78909	105-305	Blue	510J	1000W	1800VA (1000VA cUL)	8A or 2220W@277VAC
ZTL124F	cULus	78908	105-305	Green	510J	1000W	1800VA (1000VA cUL)	8A or 2220W@277VAC

ZTL124 PHOTOCONTROL																	
Z		TL		124		COVER COLOR		TURN-ON LEVEL (fc)		FAIL MODE		MOV RATING		PACKAGING QTY/COLOR		LAMP COMPATABILITY	
TECHNOLOGY	TYPE	VOLTAGE		ANSI STD. COLOR		TURN-ON LEVEL (fc)		FAIL MODE		MOV RATING		PACKAGING QTY/COLOR		LAMP COMPATABILITY			
Z	ZERO-CROSS	TL	TURN-LOCK	124	105-305VAC	BLANK	ANSI STD. COLOR	BLANK	1.5 ANSI STD.	BLANK	ON	BLANK	510J	BLANK	1 UNIT 4 COLOR	BLANK	LED
						*BR	BROWN	*10	1.0 fc ENERGY SAVER	F	OFF	*1020J	1020J	*12	12 UNITS 1 COLOR		
						*BK	BLACK	*26	2.6 fc IES RECOMMENDATION					*50	50 UNITS 1 COLOR		
						*OR	ORANGE	*35	35 fc FAA								
						*GR	GREEN	*80	8.0 fc METRO - HIGH AMBIENT								

* Special order - Consult factory for availability and pricing.

PHOTOCONTROLS

Electronic Instant Response Turn-Lock

LED Photocontrol Long Life

ZTL Series



ZTL124F
(FAIL OFF)

APPLICATIONS

- Designed meet local utility standards for street and highway lighting controls.
- All LED, CFL, Induction, HPS, MH and HID lighting fixtures requiring instant response dusk-to-dawn control.
- Ideal for roadway, area, parking, flood and security type lighting fixtures.

FEATURES

- **Zero-Cross (LED):** The ZTL Series Photoclock is microprocessor controlled with enhanced ZERO-CROSS Switching Technology allowing it to withstand the high inrush currents commonly found in all LED Luminaires.
- **Long Life:** Backed by a 15-Year Warranty, all electrical components are to exceed 15,000 ON/OFF operations and the 20 year long-life requirements needed for today's LED luminaires.
- **Light Sensor:** Superior light sensing technology driven by a molded sealed IR Filtered Non-Drifting Silicon Sensor designed for extreme accuracy and calibrated to duplicate a Human Eye Response.
- **Surge Protection:** Enhanced 510 Joule MOV component helps provide superior Photoclock and LED luminaire surge protection against unpredictable line voltage spikes.
- **Relay:** UL Listed industrial strength DC relay with positive snap action technology virtually eliminating bounce and ensuring a secure contact at each switch cycle.
- **Weather:** UV stabilized Polycarbonate housing and window with conformal coated electronics maximizing protection against extreme weather elements and moisture.
- **Safety:** Tested and certified to meet both UL and CSA Photoclock standards and the most current ANSI C136.10-2010 American National Standard for Roadway and Area Lighting Equipment.
- **Operation:** Delayed OFF response prevents false switching due to light from vehicles or lighting, etc.
- **Energy Savings:** Rated for use with LED lamp drivers.
- **Custom:** Customize your special order by choosing multiple colors, Turn-On light trigger levels, special packaging or superior surge protection magnitude to meet your specific job requirement.
- **ZTL124F**
 - **Fail OFF:** Protects LED drivers from daytime operation where additional daytime heat gain degrades electronic drivers.

SPECIFICATIONS

- **ON/OFF:** Turn-ON is 1.5 foot candle +/-0.2 OFF/ON ratio is 1.5:1 average.
- **Time Delay:** Instant ON/3 seconds OFF.
- **Cell:** Molded sealed IR filtered sensor.
- **Relay:** Rated life 15,000 operations.
- **Surge Protection:** 510 joules MOV (Metal oxide varistor) exceeds ANSI and NEMA requirements.
- **Locking Prongs:** Solid brass for maximum corrosion resistance and electrical conductivity.
- **Custom:** Available for custom design to meet specific utility specification.
- **Temperature Range:** -40 °F to +140 °F (-40 °C to +60 °C).
- **Fail Mode:** ON.
- **Tungsten/Ballast:** 1000W/1800VA.
- **Electronic Ballast/LED:** 8A or totaling 2220W@277VAC.
- **Limited Warranty:** 15 years.

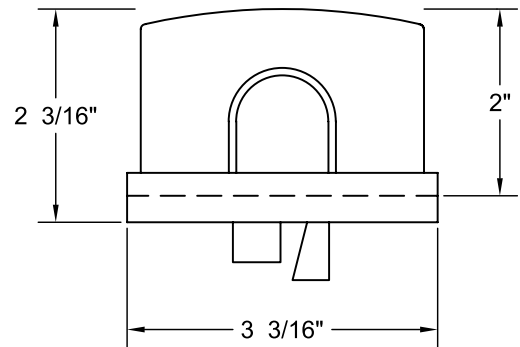

CAT. NO.	CERTIFICATION	UPC CODE	VOLTAGE VAC 50/60Hz	COLOR	MOV	RATING		
						TUNGSTEN	BALLAST	ELECTRONIC BALLAST (LED)
ZTL124	cULus	78909	105-305	Blue	510J	1000W	1800VA (1000VA cUL)	8A or 2220W@277VAC
ZTL124F	cULus	78908	105-305	Green	510J	1000W	1800VA (1000VA cUL)	8A or 2220W@277VAC

ZTL124 PHOTOCONTROL																	
Z		TL		124		COVER COLOR		TURN-ON LEVEL (fc)		FAIL MODE		MOV RATING		PACKAGING QTY/COLOR		LAMP COMPATABILITY	
TECHNOLOGY	TYPE	VOLTAGE		COVER COLOR		TURN-ON LEVEL (fc)		FAIL MODE		MOV RATING		PACKAGING QTY/COLOR		LAMP COMPATABILITY			
Z	ZERO-CROSS	TL	TURN-LOCK	124	105-305VAC	BLANK	ANSI STD. COLOR	BLANK	1.5 ANSI STD.	BLANK	ON	BLANK	510J	BLANK	1 UNIT 4 COLOR	BLANK	LED
						*BR	BROWN	*10	1.0 fc ENERGY SAVER	F	OFF	*1020J	1020J	*12	12 UNITS 1 COLOR		
						*BK	BLACK	*26	2.6 fc IES RECOMMENDATION					*50	50 UNITS 1 COLOR		
						*OR	ORANGE	*35	35 fc FAA								
						*GR	GREEN	*80	8.0 fc METRO - HIGH AMBIENT								

* Special order - Consult factory for availability and pricing.